

DF36650/S/P



FEATURES

Wolf's patented gas dual-stacked, sealed burner design provides precise high-to-low temperature control and a spark ignition system that reignites the burner automatically

Wolf's Dual VertiFlow™ convection system provides reliably even heat, reduces hot and cold spots, and enables consistent multi-rack cooking

Gourmet Mode features nearly 50 presets that automatically control the oven to ensure delicious results

Ten cooking modes, including Bake, Broil, Convection, Convection Roast, Dehydrate, Gourmet, Proof, Roast, Stone, and Warm, were developed by Wolf chefs to maximize the performance of your oven

Six dual-stacked burners produce up to 20,000 Btu for fast boils and intense sears and 300 Btu for true simmers and worry-free melts

For improved temperature control and safety, the spark ignition system reignites burners automatically

The full-color touch screen is intuitive and easy to read, discreetly hiding away when not in use

LED backlit control knobs illuminate when in use, indicating which burners are active

The oven offers self-clean, delayed start, timed cook, and Sabbath features

Temperature Probe

The oven's Wi-Fi enabled feature lets you remotely preheat, select modes, and adjust oven temperature from your mobile device

Create a cohesive look in your kitchen with the range's stainless construction, pro-style handles, and choice of iconic red, black, brushed stainless, brushed brass, or brushed grey knobs

ACCESSORIES

2-Burner Wok Grate

30" Broiler Pan

36" Dehydration Rack Set

36" Dual Fuel Brushed Brass Bezel Kit

36" Full-extension ball-bearing oven rack

36" Standard Oven Rack

Bake Stone Kit

Filler Trim

Temperature Probe

Stainless steel, brass or chrome bezels

Signature red, black, brushed stainless, brushed brass, or brushed grey knobs

Rear Caster Covers

Front Leg Extension Covers

Stainless Steel Kickplates

5" and 10" stainless steel risers, and 20" riser with shelf

Accessories available through an authorized dealer.



KNOB OPTIONS



TOP CONFIGURATION

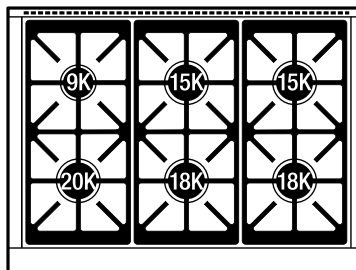

RANGETOP SPECIFICATIONS

- 1 - 9,200 Btu Burner
- 2 - 15,000 Btu Burners
- 2 - 18,000 Btu burners
- 1 - 20,000 Btu burner

PRODUCT SPECIFICATIONS

Model	DF36650/S/P
Dimensions	35 7/8"W x 36 1/2"H x 29 1/2"D
Oven 1 Interior Dimensions	31 1/4"W x 17 1/2"H x 20"D
Oven 1 Usable Capacity	4.1 cu. ft.
Oven 1 Overall Capacity	6.3 cu. ft.
Door Clearance	21"
Weight	470 lbs
Electrical Supply	240/208 VAC, 60 Hz
Electrical Service	30 amp dedicated circuit
Gas Supply	3/4" ID line
Gas Inlet	1/2" NPT female

DIMENSIONS

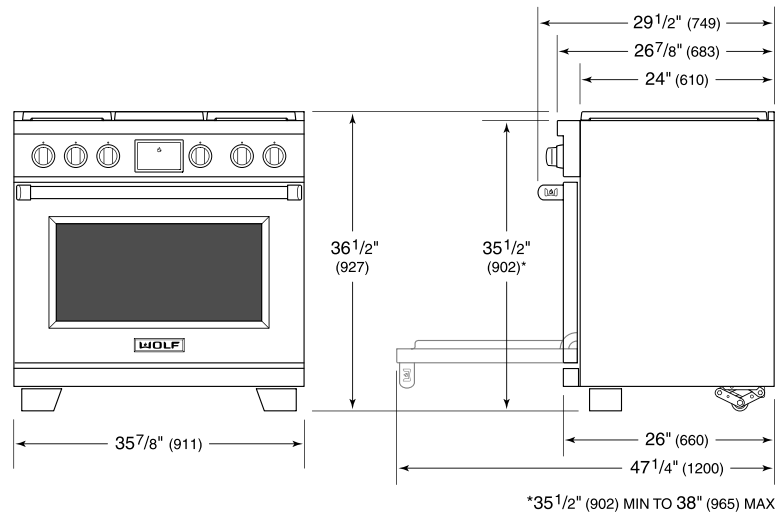

ELECTRICAL

GAS

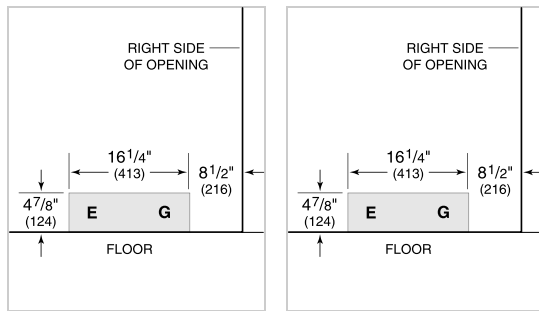

NOTE: Dimensions in parenthesis are in millimeters unless otherwise specified

STANDARD INSTALLATION

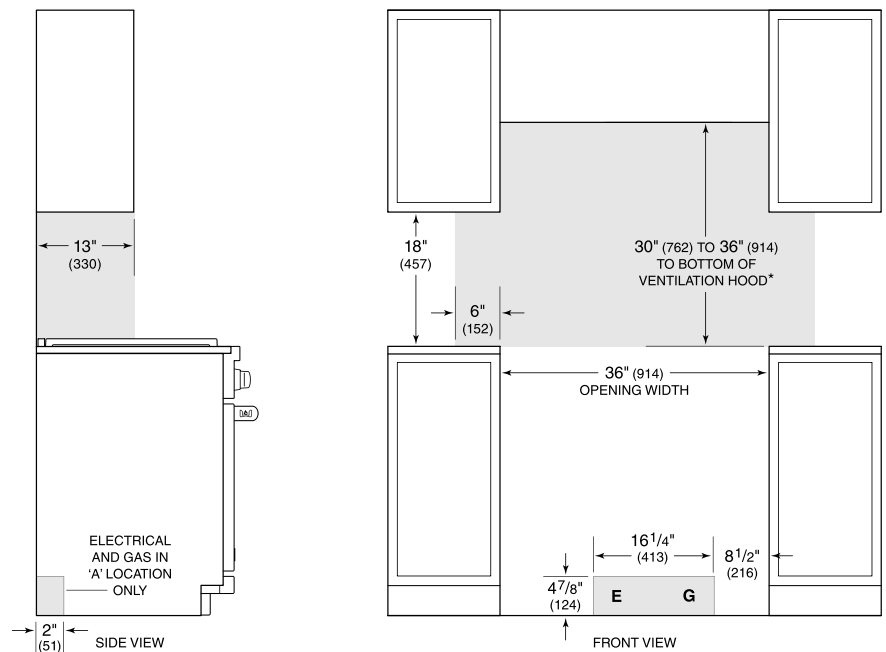

**Without ventilation hood, 36" (914) minimum clearance countertop to combustible materials, 44" (1118) for charbroiler.*

NOTE: Shaded area above countertop indicates minimum clearance to combustible surfaces, combustible materials cannot be located within this area.

For island installation, 12" (305) minimum clearance back of range to combustible rear wall above countertop.