

CL3050U/S



FEATURES

Split Climate™ intelligent cooling system revolutionizes Sub-Zero's already-superior preservation capabilities, keeping food even fresher for longer

ClearSight™ LED lighting system fully illuminates the interior and reduces shadows

Sleek stainless accents trim the interior, matching the sophistication of the exterior

Touch control panel is conveniently located for easy access at the tap of a finger

Night Mode optimizes the interior lighting based on the detected ambient light, reducing the brightness by 90% in dim environments

Lift the base of the flip-up dairy compartments to store taller items on the shelf below

Filtered ice ready on-demand and activate Max Ice Mode to temporarily increase ice production

Position adjustable door bins at various heights to accommodate assorted items

Wi-Fi enabled features provide remote access from your mobile device

Stainless-steel exterior and tubular or pro handles to match other Sub-Zero, Wolf, and Cove products

Sub-Zero offers an industry-leading full two-year warranty on appliances, along with a full five-year sealed system warranty and a limited twelve-year sealed system warranty

ACCESSORIES

Air Purification Cartridge

Dual Installation Kit

Dual Installation Kit with 60" Pro Louvered Grille

Dual Installation Kit with 66" Pro Louvered Grille

Stainless Steel Kickplate

Stainless Steel Side Panel

White Side Panel

Stainless steel kickplate

Grilles for 83" or 88" finished height (84" is standard)

Side panel mounting kit

Accessories are available through an authorized dealer.
For local dealer information, visit subzero-wolf.com/locator.

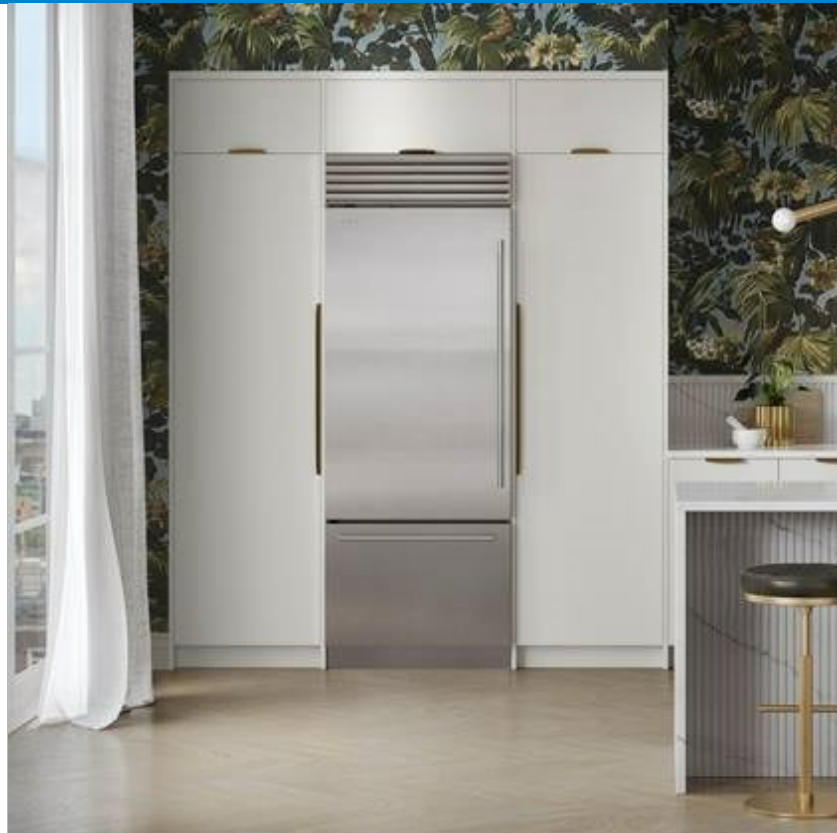

HANDLE OPTIONS

PRO



TUBULAR



PRODUCT DETAILS

REFRIGERATOR

- 4 glass refrigerator shelves (3 adjustable; 1 stationary)
- 2 crisper drawers with removable dividers
- 3 refrigerator door bins (2 adjustable; 1 stationary)
- 1 flip-up dairy compartment
- Air purification system
- LED refrigerator and freezer lights

FREEZER

- Full-extension drawer
- Water filtration system
- Automatic ice maker with removable ice container

PRODUCT SPECIFICATIONS

Model	CL3050U/S
Dimensions	30"W x 84"H x 24"D
Weight	495 lbs
Refrigerator Capacity	12.8 cu. ft.
Freezer Capacity	4.2 cu. ft.
Electrical Supply	115 VAC, 60 Hz
Electrical Service	15 amp dedicated circuit
Receptacle	3-prong grounding-type

ELECTRICAL



PLUMBING



NOTE: Dimensions in parenthesis are in millimeters unless otherwise specified

INTERIOR VIEW

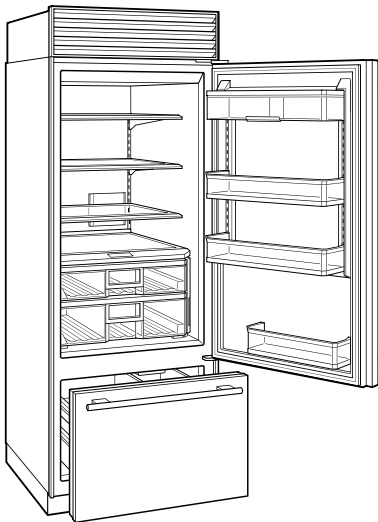

This illustration is intended for interior reference only and may not represent the exterior of the model being specified.

DIMENSIONS

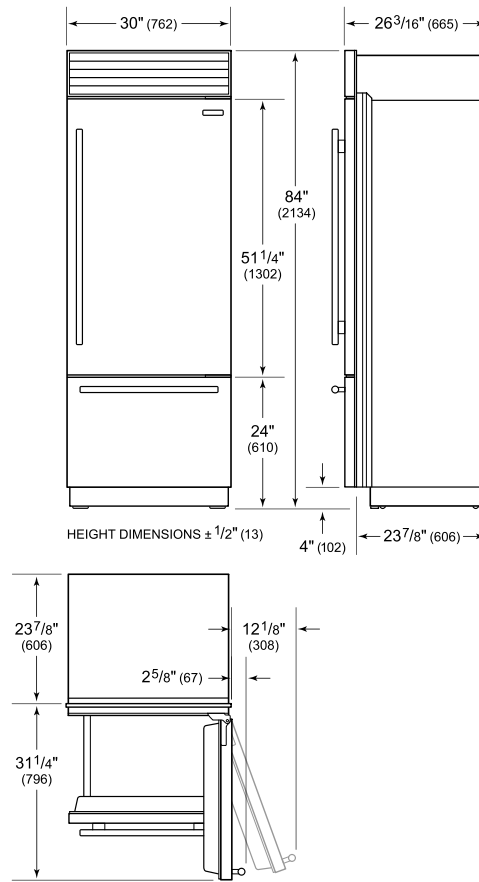

STANDARD INSTALLATION

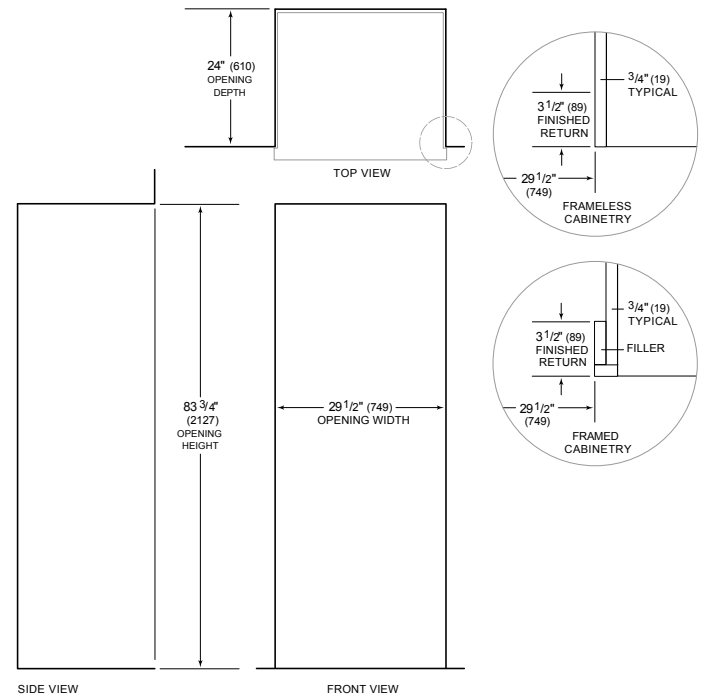

NOTE: 3 1/2" (89) finished returns will be visible and should be finished to match cabinetry. Shaded line represents profile of unit.