

COMFORT SERIES

ALLASIO BLACK & WHITE



3X LAYER
MESH FILTER



LED LIGHT

ELICA'S EXCLUSIVE
PLUS FEATURES

The slim Allasio with 4¾" height is ideal where under-cabinet space is limited, plus the contemporary styling and gleaming colors will compliment other appliances and most cabinetry. Allasio features a 3-speed, 300 CFM internal blower, which provides sufficient ventilating power for most kitchens. The attractive Soft Touch, Blue Illuminated Controls allows the user to manage blower speeds and lights.

Dishwasher-safe anodized aluminum mesh filters are easy to clean and a snap to remove and replace. Allasio is designed for standard ducted installation, and can be installed as a recirculating system, using the Recirculating Kit.

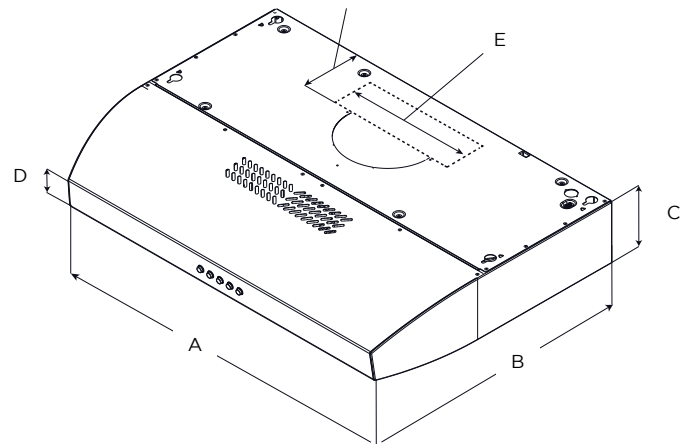

	EAL330B1	EAL330W1
A	30" (76.2 cm)	
B	20" (50.8 cm)	
C	4¾" (12 cm)	
D	2½" (5.7 cm)	
E	3¼" x 10" (8.3 x 25.4 cm)	
F	5½" (13 cm)	



SPECIFICATIONS



	30" UNIT	
Model:	EAL330B1	EAL330W1
Dimensions:	30" W x 20" D x 4 ¾" H	
Blower Type(internal):	300 CFM (3 -speed)	
Blower Performance:		
Speed 1	120 CFM	
Speed 2	210 CFM	
Speed 3	300 CFM	
Noise (sones):	Min: 1.5, Max: 5.9	
Woking Speed		
Finish:	Black	White
Controls:	Soft Touch, Blue Illuminated Controls - Front Mounted	
Illumination:	2 LED Lights	
Filter Type:	2 - Dishwasher safe anodized aluminum mesh grease filters	
Duct Transition:	7" Round with Back Draft Damper (top only)	
Installation Type:	Ducted (Recirculating Kit sold separately)	
Electrical:	120V - 60 Hz 289 Watts at 2.43 Amps	
KITS:		
Optional recirculating Kit 30":	KIT02178	
Optional Backdraft Damper/ Non return Valve 7" Round:	KIT02723	
Stainless Steel Baffle Slot Filter	GRI0131086A	GRI0131087A
CONSUMABLE PARTS:		
Grease Filter (1):	GF04BA	
Carbon Filter (1):	TM01FA	

*Consumable parts are sold in units of one (1). Order accordingly

*The product images shown are for illustration purposes only and may not be an exact representation of the product.

PLUS FEATURES



3X LAYER GREASE FILTER - Elica aluminum mesh filters are a step above competition, featuring triple layered, anodized aluminum that is woven into a highly dense mesh. The thick mesh captures more grease, anodization helps resist staining and provides durability to repeated cleanings in the dishwasher.



LED LIGHT - LED lighting is undoubtedly the smartest solution in terms of energy saving. Expected life time of over 20,000 hours, represents the most remarkable advantage of LED light bulbs.