

CustomSound™ CS610 2-Way In-Ceiling Speaker



This superb group of architectural speakers embody over 40 years of cutting edge research in the field of acoustics and loudspeaker design. Musical, refined, and nearly invisible, these speakers can create a beautiful ambience, even in larger spaces. Because their sonic signature is identical to other PSB speakers, these CS600's can integrate perfectly as part of home theatres or as the soundtrack of the connected home. Since PSB has in-room, on-wall, outdoor, in-wall and in-ceiling designs at many different price points, it makes it easy to specify an audio system that you know will turn out right, be easy to specify and install, and will absolutely thrill even your most discriminating clients.

There are three models in this series, and all feature frameless magnetic grilles with invisible scrims. Both round and square grilles are provided, simplifying and reducing your inventory requirements. Each model features an improved simple, foolproof mounting system using heavy duty doglegs. Cutting templates are included. Pre-construction brackets and backcans are also available.

CS610 2-way In-Ceiling Speaker

Featuring PSB's trademark carbon-filled polypropylene 6 1/2" woofer, this speaker has a warm and balanced sound with plenty of power handling thanks to the high temperature voice coil. The 3/4" aluminium dome tweeter, another proprietary PSB driver, is concentrically mounted and features a carefully engineered Wave Guide and ball-joint pivot mount assembly. This allows the tweeter to go lower in frequency, creating a perfect blend with the woofer in the crossover region, and allows the tweeter to be aimed toward the listening position for enhanced musical imaging. Adjustment for the level of the tweeter allows you to 'dial in' the upper frequency response of the speaker and its acoustic environment after installation to achieve the most musical balance for every room.

- 6 1/2" 2-way in-ceiling flush mount speaker
- Proprietary Imagine carbon-filled polypropylene cone with injection molded basket
- Proprietary 3/4" aluminium dome tweeter
- Aimable tweeter angle adjustment (ball-joint)
- Precision crossover network for smooth wide-band response
- Dual position switch for tweeter level
- High strength doglegs for easy installation and removal
- Includes both round and square magnetic frameless grilles

CustomSound CS610 2-Way In-Ceiling Speaker

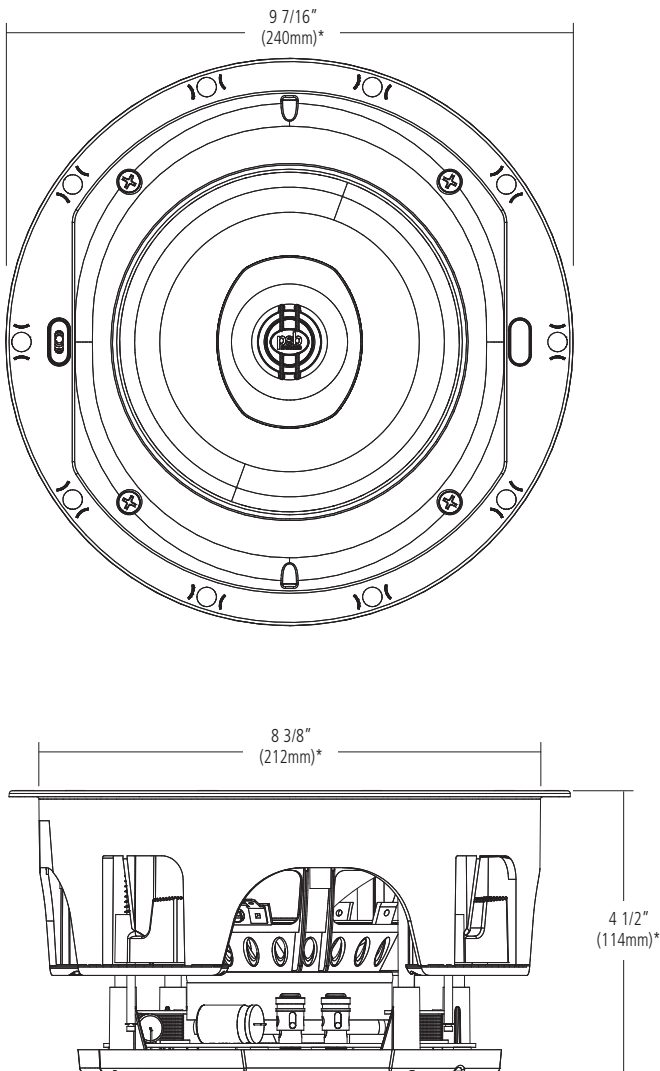

Frequency Response (Anechoic Chamber)	
On Axis @ 0°±3dB	50-20,000Hz
Sensitivity (1W (2.83V) @ 1M, IEC-Filtered pink noise, C-weighted)	
Anechoic Chamber	86dB
Listening Room	88dB
Impedance	
Nominal	6 Ohms
Minimum	4 Ohms
Input Power (RMS, Clipping <10% Time)	
Recommended	10-100 Watts
Acoustic Design	
Tweeter (Nominal)	3/4" (19mm) aluminium dome with ferrofluid Black anodized
Woofer (Nominal)	6 1/2" (165mm) Carbon-filled polypropylene cone Rubber surround
Design Type	Open back
EQ Adjustment	Tweeter switch
Size (W x H x D) (Gross Dimensions)	
Mounting Depth	4 1/2" (114mm)*
Cutout Diameter	8 3/8" (212mm)*
Grill Round	9 7/16" (240mm)*
Grill Square	9 7/16 x 9 7/16" (240mm x 240mm)* Both round and square grills supplied
Finish	
	White

* Non-metric measurements are approximate.

REAL SOUND for REAL PEOPLE
www.PSBspeakers.com