

RB10FSR4ESR

SAMSUNG

11.3 cu. ft. 2-Door Bottom Mount Refrigerator



Signature Features

Modern Design

- Clean lines and modern form blend beautifully into your kitchen.

Digital Inverter Compressor

- Automatically adjusts its speed in response to cooling demand across 7 levels. As a result, it's quieter and uses up to 50% less power.

Counter-Depth Design

- Fits seamlessly with the surface of your kitchen for harmonious look.

Energy Star Certified

- Eco-friendly and energy-efficient.

Available Colours



Stainless Steel



LED Lighting



Digital Inverter Compressor

Features

- 11.3 cu. ft. Capacity
- Modern Design with Stainless Steel Finish
- High Efficiency LED Lighting
- Adjustable Spill Proof Shelves
- Door Alarm
- Power Freeze
- Easy Slide Shelf

Convenience

- All-Around Cooling
- Cool Tight Door

Rating



ENERGY STAR® rated:
390 kWh/yr

11.3 cu. ft. 2-Door Bottom Mount Refrigerator

Installation Specifications

1. Measure the height, width and depth of the opening, making sure to include baseboards, molding tile, countertop overhang, etc. Check to be sure there is enough room to open the door (consider walls, islands or other obstacles when measuring).
2. Refer to illustration below to determine dimensions.
3. Allow 2" minimum clearance at rear for proper air circulation and water/ electrical connections.
4. Ensure each door and entryway in the home is wide enough for the refrigerator to be moved through easily.

For optimal usage and to be able to open refrigerator doors completely, do not install next to a wall.

Please note: The following dimension and cutout information is for planning purposes only. For complete installation details, consult manual packed with product, or download manual online at samsung.com.

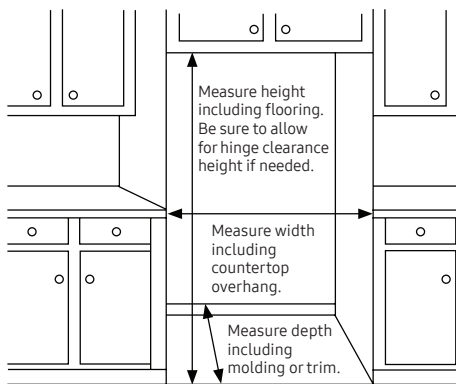

Dimensions

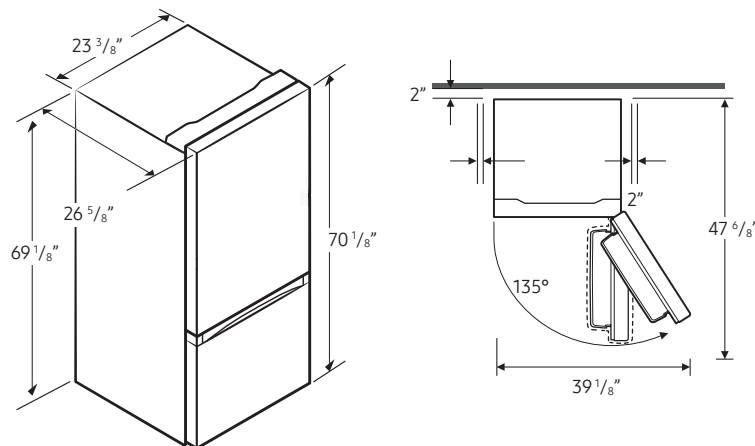

Total Capacity: 11.3 cu. ft.

Refrigerator: 7.5 cu. ft.

- All Around Cooling
- Recessed Handle
- 4 Tempered Glass Spill-Proof Shelves
- 1 Crisper
- 4 Door Bins
- High Efficiency LED Lighting

Freezer: 3.8 cu. ft.

- Three Drawers
- Side-Swing Door with Recessed Handle
- High Efficiency LED Lighting

Warranty

One (1) Year Parts and Labour on Refrigerator
Ten (10) Years Parts on Digital Inverter Compressor

Product Dimensions & Weight (WxHxD)

Dimensions (WxHxD with hinges, handles and doors):

23 ³/₈" x 70 ¹/₈" x 26 ⁵/₈"

Dimensions (WxHxD without hinges and door):

23 ³/₈" x 70 ¹/₈" x 24 ³/₈"

Dimensions (WxHxD with hinge and door, no handle):

23 ³/₈" x 70 ¹/₈" x 26 ⁵/₈"

Weight: 138.89 lbs (63 Kg)

Shipping Dimensions & Weight (WxHxD)

Dimensions: 25 ³/₄" x 73 ⁷/₈" x 27 ⁵/₈"

Weight: 152 lbs (68.95 Kg)

Colour

Stainless Steel

Model

RB10FSR4ESR

UPC Code

887276390154