

Dual Fuel Range, 30", 4 Burners, Self-cleaning, LPG

Series 9 | Professional

Stainless Steel | LPG



Get the best of gas and convection technology in this striking range with intuitive touchscreen and specialized cooking functions.

- Guided cooking using your touchscreen makes it simple to cook by food, function or recipe.
- Top burner heat of 19,000 BTU, for seriously fast boiling
- 4 cu ft total oven capacity
- Beautiful LED halo-illuminated dials provide information at a glance

DIMENSIONS

Height	35 ³ / ₄ - 36 ³ / ₄ "
Width	29 ⁷ / ₈ "
Depth	29 ¹ / ₈ "

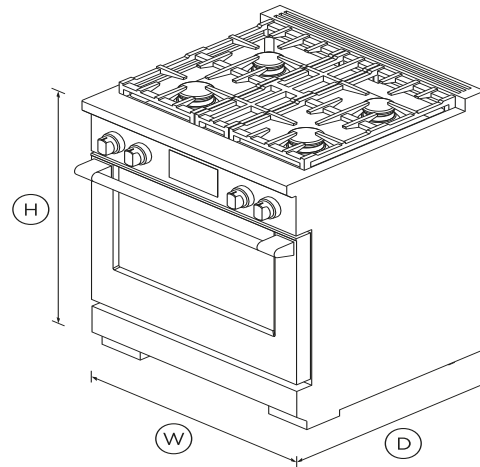

FEATURES & BENEFITS

Cook with confidence

Our touchscreen interface provides an intuitive guided cooking experience that helps deliver perfect results, whether you've been cooking all your life or just starting out. Cook with a favorite method, a hero ingredient, or a go-to cooking function or recipe. The screen tilts for improved ergonomics and optimal visibility while cooking.

Generous capacity

Featuring a generous total capacity of 4 cu ft, with enough room

to fit a 26 lb turkey, or to cook several dishes at once.

Cooking flexibility

No matter what you're cooking, you've got the right heat to get perfect results. Each of the 15 oven functions have been extensively researched and carefully designed to cater to a broad range of dishes and cooking styles. The handy food probe helps you monitor your progress.

Cooktop power

Sealed dual flow burners deliver cooktop power up to 19,000 BTU for seriously fast boiling, and precise 140°F full surface, low temperature cooking with the gentlest of flames.

Design quality

This range has craftsmanship in every detail, with real stainless steel, cast-iron trivets, and beautifully weighted, halo illuminated dials. Each cavity features incandescent lights and full extension telescopic racks. From the robust legs to the powerful cooktop, this Range is built to last.

Easy to clean

The oven features a self-cleaning function and self-clean proof side racks, which don't need to be removed when using this function.

SPECIFICATIONS

Accessories

Square handle option	AH-R30
----------------------	--------

Cleaning

Pyrolytic self-clean	•
----------------------	---

Controls

High resolution display	•
Sabbath mode	•

Gas requirements

Fitting and pipe	½ NPT, min. ⅝" Ø flex
Supply Pressure (LPG)	11" to 14" W.C

Oven features

Broil pan	•
Concealed element	•
Electronic oven control	•
Full extension telescopic	2
Internal light	•
Pyrolytic self-clean	•

Oven functions

Pyrolytic self-clean	•
----------------------	---

Power requirements

Supply frequency	60Hz
Supply voltage	120 - 240V

Product dimensions

Depth	29 1/8 "
Height	35 3/4- 36 3/4 "
Width	29 7/8 "

Rangetop features

Sealed Dual Flow Burners™	4
Simmer on all burners	140°F
Vent trim included	Flat vent trim

Rangetop Performance

Max burner power	19000BTU
Power back left	13000BTU
Power back right	13000BTU
Power front left	19000BTU
Power front right	15000BTU
Total cooktop power	60000BTU

Safety

Full extension telescopic	2
---------------------------	---

Warranty

Parts and labor	Limited 2 Years Parts & Labor
-----------------	-------------------------------

SKU	81901
-----	-------

The product dimensions and specifications in this page apply to the specific product and model. Under our policy of continuous improvement, these dimensions and specifications may change at any time. You should therefore check with Fisher & Paykel's Customer Care Centre to ensure this page correctly describes the model currently available. © Fisher & Paykel Appliances Ltd 2019.

Other product downloads available at fisherpaykel.com

User Guide



Guide D'Utilisation



Service & Warranty Booklet



Installation Guide



Guide D'Installation

**A PEACE OF MIND SALE****24 Hours 7 Days a Week Customer Support****T 1300 650 590 W www.fisherpaykel.com**