

# Oven, 30", 17 Function, Self-cleaning

Series 9 | Minimal

Black



With elegant minimal styling, advanced cook functions and touchscreen, this large built-in oven is a highlight of our collection.

- Guided cooking using your touchscreen makes it simple to cook by food, function or recipe.
- 4.1 cu ft total capacity, with 17 oven functions including Aero™ Pastry and Roast, Air Fry and Dehydrate
- Non-tip, full extension sliding shelves for safe removal of hot dishes
- Accessories include food probe, smokeless grill tray, and more

## DIMENSIONS

Height	27 <sup>3</sup> / <sub>16</sub> "
Width	29 <sup>15</sup> / <sub>16</sub> "
Depth	23 <sup>15</sup> / <sub>16</sub> "

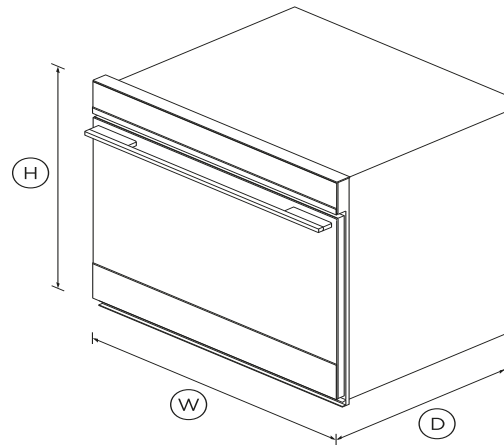

## FEATURES & BENEFITS

### Cook with confidence

Our touchscreen interface provides an intuitive guided cooking experience that helps deliver perfect results, whether you've been cooking all your life or just starting out. Cook with a favorite method, a hero ingredient, or a go-to cooking function or recipe.

### Generous capacity

With its 4.1 cu ft total capacity, you can create several perfectly cooked dishes at once using multiple shelves.

### Multi-function flexibility

The cooking functions have each been tailored, tested, tweaked and perfected to ensure that no matter what you're cooking, you've got the right heat to match. A food probe precisely monitors cooking in real time, giving you complete control.

### Exceptional performance

AeroTech circulates heat evenly for a consistent temperature throughout the cavity, helping you ensure perfect results even when cooking on multiple shelves.

### Self-cleaning

Our self-clean technology breaks down food residue at a very high temperature, leaving a light ash that's easily removed with a damp cloth. The enamel coated side racks don't need to be removed when using this function.

### Design freedom

Available in an elegant black or a stylish black with stainless steel, this oven is designed to fit seamlessly into your kitchen. Premium materials and detailing to support a cohesive, considered kitchen design.

## SPECIFICATIONS

### Accessories

Full extension sliding shelves	3 sets
Grill rack	1
Roasting dish	1
Self cleaning side runners	1 set
Smokeless grill tray	1

### Capacity

Shelf positions	8
Total capacity	4.1 cu ft
Usable capacity	3.6 cu ft

**Cleaning**

- Acid resistant graphite enamel •
- Removable oven door •
- Removable shelf runners •
- Self-clean **Standard and light cycles**

**Controls**

- Adjustable audio and display •
- Automatic cooking/minute •
- Automatic pre-set •
- Celsius/Fahrenheit •
- Connected Fisher and Paykel •
- Electronic clock •
- Electronic oven control •
- Food probe •
- Guided cooking by food type •
- Interior light **3 x 20W halogen**
- Intuitive touchscreen display •
- Multi-language display **UK English, US English,**
- Precise electronic temperature •
- Sabbath mode with Star K •

**Functions**

- Aero Broil •
- Aero™ Bake •
- Air fry •
- Bake •
- Broil •
- Classic bake •

- Dehydrate •
- Maxi Broil •
- Number of functions **17**
- Pastry Bake •
- Pizza bake •
- Rapid proof •
- Roast •
- Self-clean function •
- Slow cook •
- True Aero •
- Vent bake •
- Warm •

**Performance**

- AeroTech™ technology •
- Automatic rapid pre-heat •
- Broil power **4400W**
- Broil width **20"**
- Number of passes on Maxi Broil **12**
- Number of passes on broil **10**

**Power requirements**

- Amperage **16.6 - 19.4A**
- Supply voltage **208 - 240V**

**Product dimensions**

- Depth **23 <sup>15</sup>/<sub>16</sub> "**
- Height **27 <sup>3</sup>/<sub>16</sub> "**
- Width **29 <sup>15</sup>/<sub>16</sub> "**

**Safety**

- Advanced cooling system •
- Balanced oven door •
- Catalytic venting system •
- Control panel key lock •
- CoolTouch door •
- Full extension sliding shelves •
- Non-tip shelves •

SKU **81910**

The product dimensions and specifications in this page apply to the specific product and model. Under our policy of continuous improvement, these dimensions and specifications may change at any time. You should therefore check with Fisher & Paykel's Customer Care Centre to ensure this page correctly describes the model currently available. Â© Fisher & Paykel Appliances Ltd 2019.

---

**Other product downloads available at fisherpaykel.com**



User Guide



Guide D'Utilisation



Service & Warranty Booklet



Installation Guide



Resources (zip)



**A PEACE OF MIND SALE**

**24 Hours 7 Days a Week Customer Support**

**T** 1300 650 590 **W** [www.fisherpaykel.com](http://www.fisherpaykel.com)