



46-INCH GAS COOKTOP

HPCT466G | PROFESSIONAL STYLE



FEATURES & BENEFITS

- Exclusive Bead-Blasted, PermaClean™ Finish on a one-piece sealed spill basin makes cleaning easy and keeps cooktop scratch-free.
- Continuous Platform Grates are porcelain coated and allow extra large pots and pans to be moved effortlessly from burner to burner.
- Burner Configuration: 6 Burners (64,500 Total BTUs)
 - 2 Sealed Gas Burners (14000 BTU)
 - 1 Sealed Gas Burner (12500 BTU)
 - 3 Sealed Gas Burners (8,500 BTU) - HPCT466
- Perma-Flame™ Technology automatically re-ignites a flame for continuous heating and uninterrupted cooking should a burner unexpectedly go out.
- Exclusive SmartFlame™ Technology reduces flame contact with grate to prevent grate discoloration and increase longevity.
- Brass Burners and Valves for superior reliability and longevity.
- Downdraft Compatible.

GENERAL PROPERTIES

FINISH STAINLESS STEEL

OPTIONAL ACCESSORIES

WOK RING AWR

SIMMER PLATE ASP10

TECHNICAL INFORMATION

ELECTRICAL REQUIREMENTS 120VAC/60HZ/15AMP

GAS CONFIGURATIONS
NG - NATURAL GAS
NG / H - NATURAL GAS / HIGH ALTITUDE
LP - LIQUID PROPANE
LP / H - LIQUID PROPANE / HIGH ALTITUDE

PRODUCT DIMENSIONS

APPLIANCE DIMENSIONS (H X W X D) (IN.) 4" X 46" X 21"

ALL TOLERANCES - 1/16" (- 1.6MM) UNLESS OTHERWISE NOTED

HPCT466

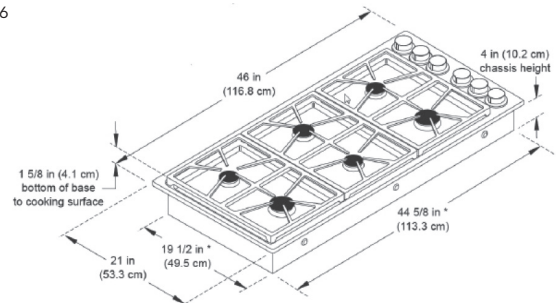

* INCLUDING EMBOSSES/SCREWS IN SIDE OF CHASSIS

| CONFIGURATION | CUTOUT TYPE | (C) | (D) | (E) | (F) | (G) | (H) |
|------------------------------|-------------|-----------------|-------------------|---------------------|-------------------|--------------|-------------------|
| HPCT466 W/O DOWNDRAFT | SQUARE | 2 7/8" (7.3 CM) | 19 3/4" (50.2 CM) | 44 1/2" (113.03 CM) | NA | NA | NA |
| HPCT466 WITH DOWNDRAFT PRV46 | NOTCHED | 3/8" (1.0CM) | 22 1/2" (57.2CM) | 44 1/2" (113.03CM) | 43 1/2" (110.5CM) | 5/8" (1.6CM) | 2 5/8" ** (6.0CM) |

*Total cutout depth accommodates both the cooktop and downdraft.

**IMPORTANT: Notch depth is included in total cutout depth (D).

DO NOT add notch depth to total cutout depth (D).

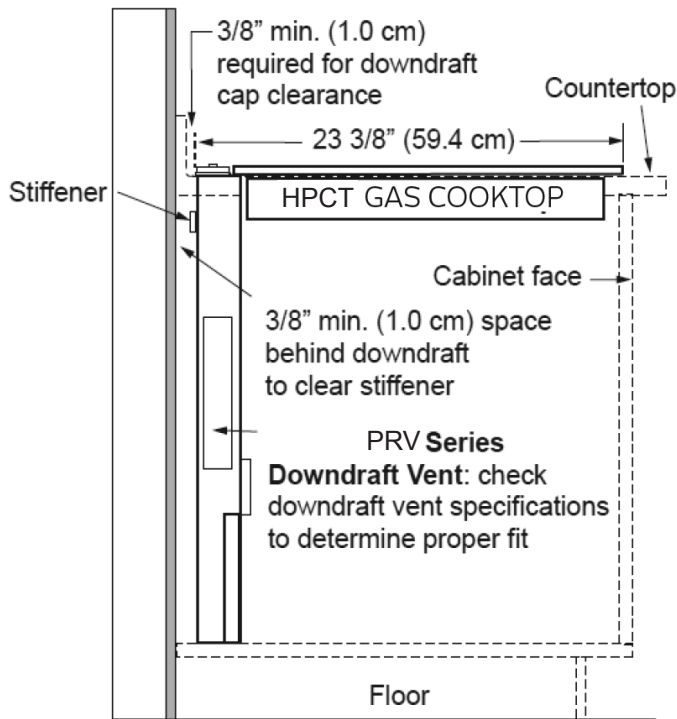

Cooktop with PRV Series Downdraft Vent

