



## 24" MICROWAVE

DMW2420 | HERITAGE COLLECTION



### AVAILABLE MODELS

DMW2420S 24" Heritage Microwave - Stainless Steel

### FEATURES & BENEFITS

- 1,100 Watts of power for fast reheating and cooking.
- Sensor Technology automatically adjusts time and temperature for 9 popular microwave favorites including popcorn, reheat, fresh vegetables, frozen entrees, rice, baked potatoes, ground meat, and poultry, as well as fish and seafood.
- Menu Options provide 6 convenience selections to assist with meal preparation - Breakfast, Lunch, 15 Minute Recipes, Defrost, From The Pantry and Beverages.
- Keep Warm lets you keep hot foods hot up to 30 minutes after cooking is finished with no loss of quality.
- Three Defrost Options quickly defrost meats and poultry by weight. Specific programs for each category assures excellent, even results.
- Auto Start Option allows you to program the microwave to begin cooking at a designated time.
- Easy Minute provides users one minute of high power cooking at a touch.
- 2.0 Cubic Feet Capacity perfect for large families or entertaining.
- Stand Alone or built-in installations.

### PRODUCT SPECIFICATIONS

INTERIOR CAPACITY	2.0 CU. FT.
OVERALL DIMENSIONS (H X W X D) (IN.)	13 3/8" X 24" X 19 1/8"
ELECTRICAL REQUIREMENTS	120V, 15A POWER LOAD: 13A

### TRIM KITS

ACCESSORY TRIM KIT, BLACK	ADMWTK301B
ACCESSORY TRIM KIT, BLACK	ADMWTK271B
ACCESSORY TRIM KIT SS	ADMWTK301S
ACCESSORY TRIM KIT SS	ADMWTK271S

### PRODUCT DIMENSIONS

All tolerances:  $\pm$  1/16 (+/-1.6MM) unless otherwise stated.

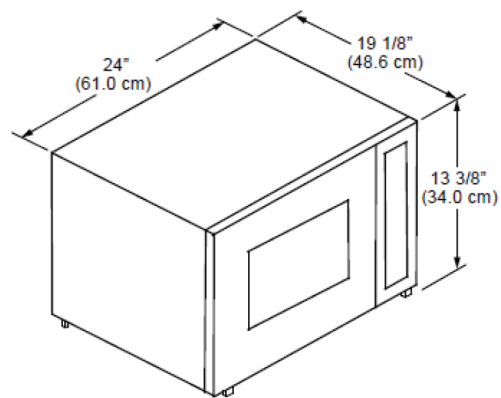

Shipping weight: 46 lbs.

Circuit required: 120 Vac, 15 Amp. dedicated, grounded, 3-prong electrical outlet

Total connected load: 13.0 Amp. @ 120 Vac, 60 Hz.

Interior dimensions: 10 1/2" H x 17 3/8" W x 18 5/8" D, interior walls are recessed