



42" STAINLESS STEEL WALL CHIMNEY HOODS

DHW421 | HERITAGE COLLECTION



GENERAL PROPERTIES	
FINISH	STAINLESS STEEL
OPTIONAL ACCESSORIES	
RECIRCULATION KIT	AVDHI
NUMBER OF MOTORS	
(1) SINGLE BLOWER	600 CFM
TECHNICAL INFORMATION	
CIRCUIT REQUIREMENTS	120VAC, 15AMP, GROUNDED DEDICATED, 3-WIRE CIRCUIT
TOTAL CONNECTED LOAD	120VAC/60HZ
MAX CURRENT DRAW	3.6 AMPS
SHIPPING WEIGHT	71 LBS
PRODUCT DIMENSIONS	
WALL DIMENSIONS (H X W X D) (IN.)	30"-42" X 42" X 24"

FEATURES & BENEFITS

- 8" diameter exhaust. Can accommodate up to a 10" duct.
- Squirrel cage style blower. 4 blower speeds.
- Auto off setting after 4 hours.
- Blue illuminated electronic control panel.
- 10 minute Timer (motor runs for 10 minutes and then automatically shuts off).
- 20 watt halogen lights (can be used w/ 10, 20, or 30w bulbs)
- Easy-to-clean Baffle Filter System, dishwasher safe.
- Hood can be installed to exhaust through the ceiling or rear wall

DHW MODEL

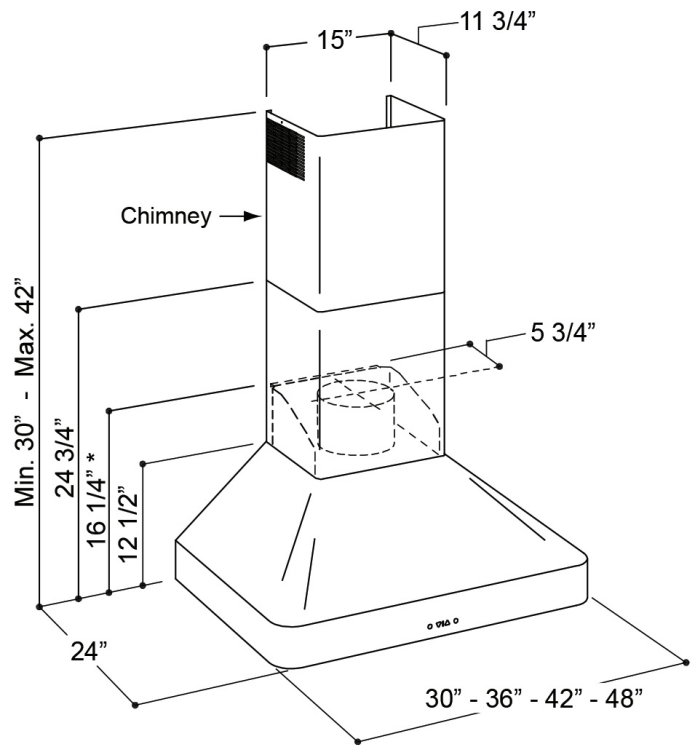

**Warranty: Limited, parts and labor for one year