

Radius **series**

O w n e r s M a n u a l

Contents

| | |
|---|---|
| Contents | 1 |
| Introduction | 2 |
| Set Up and Positioning | 2 |
| Radius One | 2 |
| Radius 200 | 2 |
| Positioning - Front Speakers | 3 |
| Positioning - Surround Speakers | 3 |
| Optimum Speaker Placement | 4 |
| Fixing the Radius 225/ Radius One to a Wall | 5 |
| Radius 270 Feet and Spikes | 6 |
| Specifications | 7 |
| Owner Information | 8 |



Introduction

Congratulations and thank you for your purchase of the Radius Series loudspeakers. We are confident they will provide years of enjoyment and pleasure as only high quality components have been used throughout.

Please follow this user manual carefully as it contains important information about positioning and set up procedures. For further advanced information please refer to our web site at: www.monitoraudio.com



The Radius 45 incorporates a thermal protection device, which helps to protect the drive unit and tweeter from permanent damage. If the speaker stops working after a long period of play, turn off the source for about 10 minutes, and retry.

Set Up and Positioning

Although position and suitability will have been considered prior to purchasing these loudspeakers, this section will guide optimum positioning and set up (an illustration is provided on page 4 to assist with positioning). For instructions on fitting the Radius 225 or Radius One to a wall, please refer to page 5. The Radius One features fixings compatible with a Sanus Wall Bracket.

NOTE: The Radius 45 and 90 can be fixed to a wall using our Universal Speaker Mount sold separately. The Radius 200 is not designed to be wall mounted.

Self adhesive rubber feet are provided to prevent movement due to vibration when using the Radius Series loudspeakers on a table/ equipment stand. The Radius 270 comes supplied with rubber feet fitted into the plinth for use on hard floors. Further details on these can be found on page 10.

Radius One

The Radius One can be placed either just below or just above your TV/ projector screen. It can be wall mounted with the supplied bracket (refer to page 5), or alternatively using the Sanus VMA202 Soundbar Speaker Mount. refer to www.sanus.com for further information.

Radius 200

The Radius 200 is the range's first dedicated centre speaker, and is designed to be placed on a shelf or cabinet.

Positioning - Front Speakers

The centre channel should be the first speaker positioned in a home theatre room, and such that the tweeter is directed towards the listener's ear. The centre channel's job is to anchor dialogue and other on-screen sounds to the screen. Typically, as much as 60% of a movie soundtrack comes through the centre channel.

The centre channel can be placed either above or below the TV screen, and as close as possible. If positioned in a cabinet or sitting on top of the TV, ensure that the front edge is aligned with the front edge of the TV or shelf. Where possible, the height of the centre channels' tweeter should be close to the height of the front speakers' tweeter — ideally, within about 600mm.

When placing Radius loudspeakers on the wall around a plasma/ LCD TV, the left and right speakers need to be between 22 & 30° to the left and right of the seating position, with the tweeters at approximate ear level.

Positioning - Surround Speakers

Ideally, the primary pair of surround speakers should be placed to the left and right of the listening position — either in line with it, or just behind it (90 - 110°). If using a 6.1 or 7.1 channel system with more than two surround speakers, or if side placement isn't available in a 5.1 channel system, consider placement behind the listening position, facing the front of the room (135 - 150°).

Surround speakers should be placed high enough so that the drivers do not fire directly at ear level when sitting down — one rule of thumb is to place them at ear level while standing, to avoid overpowering the front speakers.

If the surrounds are mounted on brackets on the side walls, experiment with aiming them.

Surround speaker placement ideal for home theatre, may not necessarily be so for multichannel music listening, where a precisely focused rear soundstage is best. If both types of listening are important, position them as a compromise between the two.

Optimum Speaker Placement

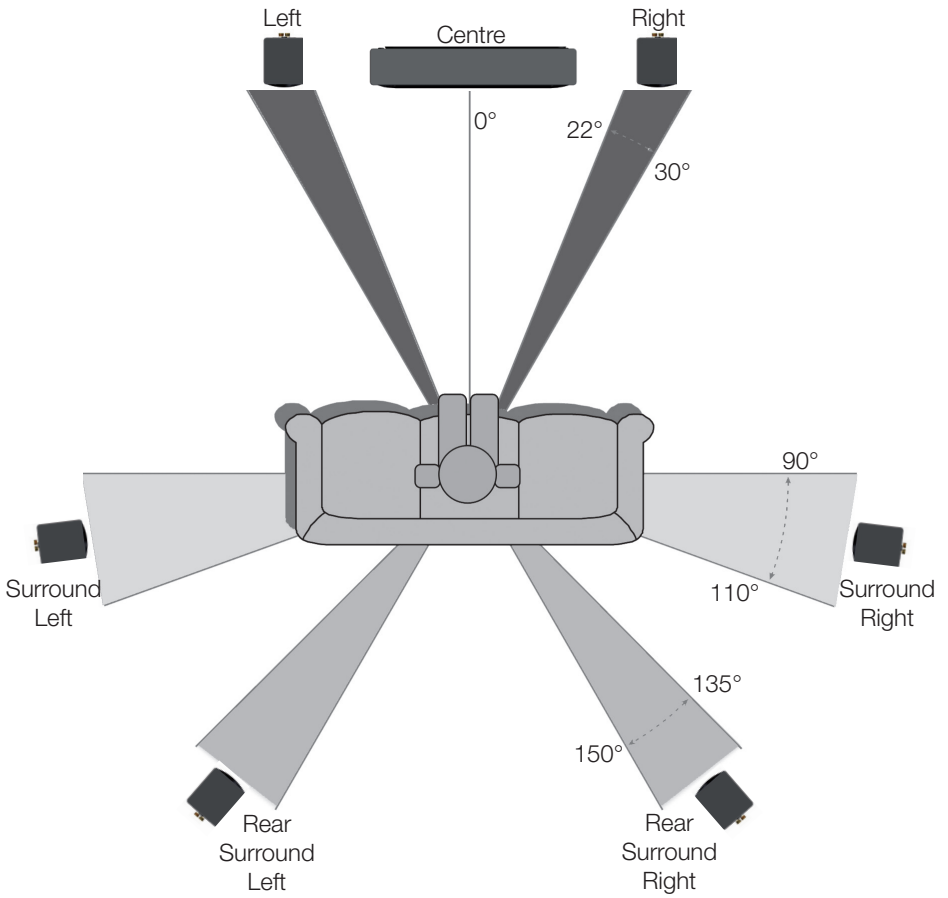

Fixing the Radius 225/ Radius One to a Wall

Additional Points to Remember

- When using the wall fixing plate, the speaker will drop by 7.5mm due to the key hole fixing.
- Templates are supplied with the products to aid fixing.
- The Radius 225 grille badge can be rotated, simply by applying some pressure with your thumb/ finger and turning.
- Please allow no more than 100mm (4 inches) of excess cable protruding from the wall. Any excess cable can be coiled inside of the terminal panel.
- Please see the template for suggested rubber foot placement.

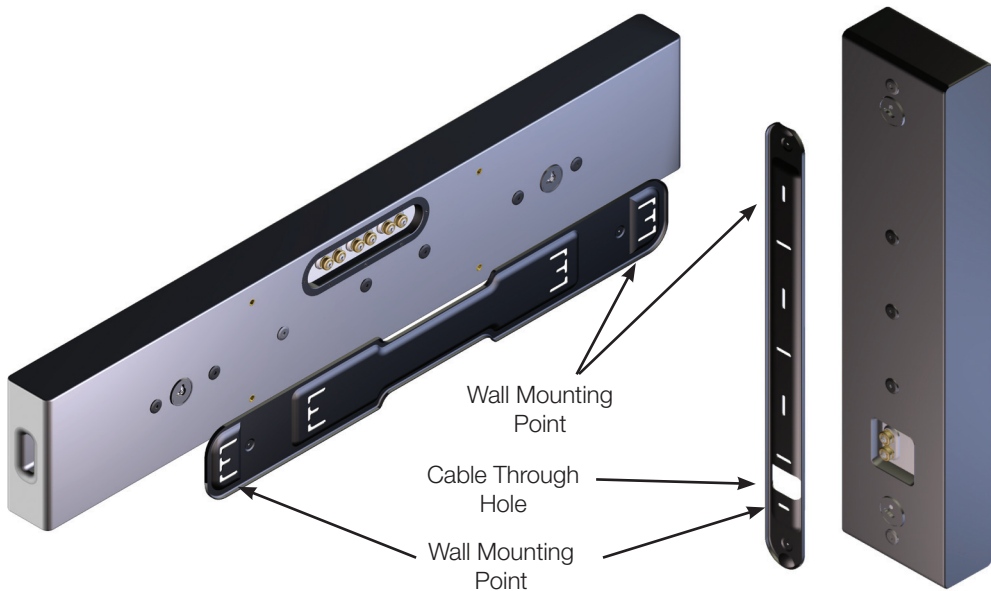

Radius 270 Feet and Spikes

The Radius 270 is supplied pre-installed with rubber feet for use on hard floors, or when spikes are inappropriate.



If using spikes, first remove the rubber feet by simultaneously twisting and pulling them out, revealing the threaded inserts.



Take the spikes and twist them in a clockwise direction in to the plinths. Ensure they are fully inserted, stand the cabinet up and place it in its final location. To level, adjust the spikes accordingly, before finally tightening the knurled locking nut to hold the spikes in that position.

| Model | Radius 45 | Radius 90 | Radius 200 | Radius 225 | Radius 270 | Radius One |
|--|---|---|---|---|---|---|
| Frequency Response | 120Hz – 20 KHz | 80Hz – 35 KHz | 60 Hz – 35 KHz | 80Hz – 35KHz | 50Hz – 35KHz | 90Hz – 35KHz |
| Sensitivity (1W@1M) | 87dB | 83dB | 86dB | 87dB | 87dB | 87dB |
| Nominal Impedance | 8 Ohms | 8 Ohms | 6 Ohms | 6 Ohms | 6 Ohm | 6 Ohms |
| Power Handling Single (RMS) | 25W | 75W | 100W | 100W | 100W | 75W |
| System Power Handling (RMS) | 50W | 100W | 100W | 150W | 150W | 100W |
| Recommended Amp Requirements | 15-50 W | 30-100 W | 40-150W | 40-150W | 40-150W | 30-100W |
| Maximum SPL (dBA) | 101 | 105 | 105 | 108 | 108 | 108 |
| Bass Alignment | Sealed Cabinet | Bass reflex –rear ported | Bass reflex – rear ported | Bass reflex – front ported | Bass reflex – front & rear ported | C: Bass reflex – front ported L/R: Bass reflex – ported to sides |
| Drive Unit Complement | 1 x 3" MMP2 cone mid-bass driver. 1 x 20mm C-CAM gold dome tweeter | 1 x 4" C-CAM cone bass/ mid driver. 1 x 25mm C-CAM gold dome tweeter | 2 x 4" C-CAM cone bass/ mid driver. 1 x 25mm C-CAM gold dome tweeter | 2 x 4" C-CAM cone bass/ mid driver. 1 x 25mm C-CAM gold dome tweeter | 2 x 4" C-CAM cone bass/ mid driver 1 x 25mm C-CAM gold dome tweeter | 3 x 4" C-CAM cone bass/ mid driver. 3 x 25mm C-CAM gold dome tweeter |
| Cabinet Dimensions (H x W x D). | 100 x 100 x 100mm (3 15/16 x 3 15/16 x 3 15/16) | 198 x 125 x 140mm (7 13/16 x 4 15/16 x 5 1/2") | 125 x 330 x 140mm (4 15/16 x 13 x 5 1/2") | 610 x 140 x 67mm (24 x 5 1/2 x 2 5/8") | 1000 x 177 x 208mm (39 3/8 x 6 15/16 x 8 3/16") (inc plinth without spikes) | 175 x 980 x 67mm (6 7/8 x 38 9/16 x 2 5/8") |
| External Dimensions Inc Grille and Terminals. (H x W x D). | 100 x 100 x 124mm (3 15/16 x 3 15/16 x 4 7/8") | 198 x 125 x 165mm (7 13/16 x 4 15/16 x 6 1/2") | 125 x 330 x 164mm (4 15/16 x 13 x 6 7/16") | 610 x 140 x 77mm (24 x 5 1/2 x 3 1/16") | 1025 x 177 x 208mm (40 3/8 x 6 15/16 x 8 3/16") (inc plinth with spikes) | 175 x 980 x 79mm (6 7/8 x 38 9/16 x 3 1/8") |
| External Dimensions Inc Grille Bracket. (H x W x D). | 100 x 100 x 162mm (3 15/16 x 3 15/16 x 6 3/8") | 198 x 125 x 203mm (7 13/16 x 4 15/16 x 8") | N/A | 610 x 140 x 84mm (24 x 5 1/2 x 3 5/16") | N/A | 175 x 980 x 84mm (6 7/8 x 38 9/16 x 3 5/16") |
| Weight (each) Kg (lb) | 1Kg (2lb 4oz) | 2. 1Kg (4lb 10oz) | 3.6Kg (7lb 14oz) | 4..2Kg (9lb 4oz) | 9.9Kg (21lb 12oz) | 7. 4Kg (16lb 4oz) |

Owner Information

Product Details

Model

Product Serial No

Date of Purchase

Dealer Details

Dealer Name

Address

.....

e-mail address

Monitor Audio reserves the right to alter specifications without notice.



Monitor Audio Ltd.
24 Brook Road
Rayleigh, Essex
SS6 7XJ
England

Tel: 01268 740580

Fax: 01268 740589

Email: info@monitoraudio.co.uk

monitoraudio.com

Designed and Engineered in the UK

Made in China.

© 2013. Version 1