



## PRD364WDHC

- 36" Professional Series Pro Harmony Standard Depth Dual Fuel Range
- PRD364WDHC

### INNOVATION

- The perfect blend of professional grade cooking with a New Contemporary Design that will fit seamlessly into any Kitchen style with a color TFT interface for a full range of cooking functions
- Exclusive, patented Star® Burner – most even heating, unsurpassed flame coverages
- QuickClean Base® designed for easy surface cleaning
- Precision simmering capabilities as low as 100°F (375 BTU) with 2 ExtraLow® Simmer burners
- Superfast 2-hour self-clean mode - fastest in the industry

### PERFORMANCE

- Professional style, continuous cast iron grates
- Continuous porcelain, easy to clean cooking surface
- Every burner 18,000 BTU (NG)
- Widest range of simmer options from 375 BTU to 3,000 BTU
- Star® design delivers superior heat spread for any size pan
- Simmer without stirring/scorching with exclusive ExtraLow®
- Superior griddle results-6 pass, 1630 watt electric griddle
- Titanium surface non-stick, rust-proof cast-aluminum griddle
- Grill accessory-thermostatically controlled for even heating
- Titanium surface non-stick, rust-proof cast-aluminum grill accessory
- Removable griddle and grill accessory for easy clean-up
- Powerful, 8-pass bake and broil elements
- Third Element Convection offers precise airflow for cooking on multiple levels without flavor transfer
- Massive oven capacity of 5 cu.ft.
- Six rack levels for multiple item cooking
- Full Access® telescopic rack, with integrated easy-grip handle
- Electronic oven control ensures precise heating
- Large oven door window for maximum viewing
- Powerful halogen lighting illuminates the oven cavity
- Sabbath mode

### DESIGN

- Bold Professional design
- Truly Flush Mounted™, 24" standard cabinet depth
- Patented Pedestal Star® Burner with QuickClean Base®
- Restaurant style metal knobs
- Signature blue indicator lighting
- 36" units ship standard with island trim included

### Optional accessories

PA12CHPBLK 12" Professional Chopping Block Acc  
PA12GRILLN 12"Grill Plate, Fusion Coating

### Included accessories

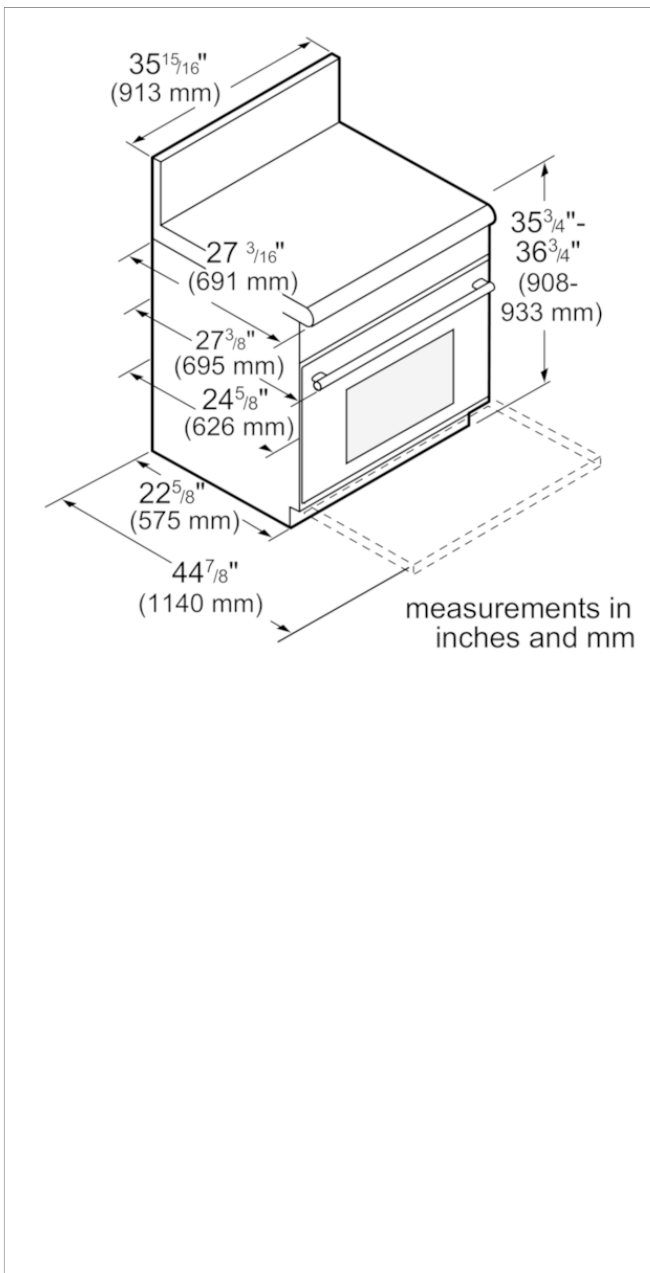

### Product Features

Total number of cooktop burners: 6  
 Cooking mode: 3rd element convection, Centre-area grill/broiler, Convection Bake, Convection Broil, Conventional heat, Roaster function, Selfcleaning pyrolytic  
 Integrated Cleaning system: Self Clean  
 Type of control: Electronic  
 Knob Material: Full metal  
 Sealed Burners: Yes  
 Number of Double grates: 2  
 Bake Element Wattages cavity 1 (W): 2000  
 Convection Element Wattages cavity 1 (W): 2750  
 Number of gas burners: 4  
 Location of 1st heating element: front left  
 Power of 1st burner (BTU): 18000  
 Location of 2nd heating element: center left  
 Location of 3rd heating element: back left  
 Power of 3rd burner (BTU): 15000  
 Location of 4th heating element: middle back  
 Location of 5th heating element: back right  
 Power of 5th burner (BTU): 15000  
 Location of 6th heating element: center right  
 Power of griddle element: 1630  
 Safety device: automatic reignition, Electronic flame control, Overheating protection, Thermostat

### Consumption and connection features

UPC code: 825225925224  
 Product color:  
 Gas type:  
 Alternative gas type: Liquid gas 27,5 mbar (USA)  
 Natural Gas Connection Rating (BTU): 66000  
 Watts (W): 8200  
 Current (A): 50  
 Volts (V): 240/208  
 Frequency (Hz): 60  
 Approval certificates: CSA  
 Required cutout size (HxWxD) (in): 36" width slide-in  
 Overall appliance dimensions (HxWxD) (in): 35 7/8" x 35 15/16" x 24 3/4"  
 Variable cooker height (in): 1"  
 AHAM volume (of cavity) - cavity 1: 3  
 Product packaging dimensions (HxWxD) (in): 49 1/4 x 43 1/2 x 40 3/8  
 Net weight (lbs): 410  
 Gross weight (lbs): 417

2019-04-24