



PRD304WHC

- 30" Professional Series Pro Harmony Standard Depth Dual Fuel Range
- PRD304WHC

INNOVATION

- The perfect blend of professional grade cooking with a New Contemporary Design that will fit seamlessly into any Kitchen style
- Exclusive, patented Star® Burner – most even heating, unsurpassed flame coverages
- QuickClean Base® designed for easy surface cleaning
- Precision simmering capabilities as low as 100°F (375 BTU) with 2 ExtraLow® Simmer burners
- Superfast 2-hour self-clean mode - fastest in the industry

PERFORMANCE

- Professional style, continuous cast iron grates
- Continuous porcelain, easy to clean cooking surface
- Every burner 18,000 BTU (NG)
- Widest range of simmer options from 375 BTU to 3,000 BTU
- Star® design delivers superior heat spread for any size pan
- Simmer without stirring/scorching with exclusive ExtraLow®
- Powerful, 8-pass bake and broil elements
- Third Element Convection offers precise airflow for cooking on multiple levels without flavor transfer
- Massive oven capacity of 4.4 cu.ft.
- Six rack levels for multiple item cooking
- One Full Access® telescopic rack and two standard racks, all with integrated easy-grip handle
- Electronic oven control ensures precise heating
- Large oven door window for maximum viewing
- Powerful halogen lighting illuminates the oven cavity
- Sabbath mode

DESIGN

- Bold Professional design
- Truly Flush Mounted™, 24" standard cabinet depth
- Patented Pedestal Star® Burner with QuickClean Base®
- Restaurant style metal knobs
- Signature blue indicator lighting
- 30" units ship standard with island trim included

Optional accessories

PA12CHPBLK 12" Professional Chopping Block Acc
PAGRIDDLE Professional Griddle Accessory

Included accessories

825225924821

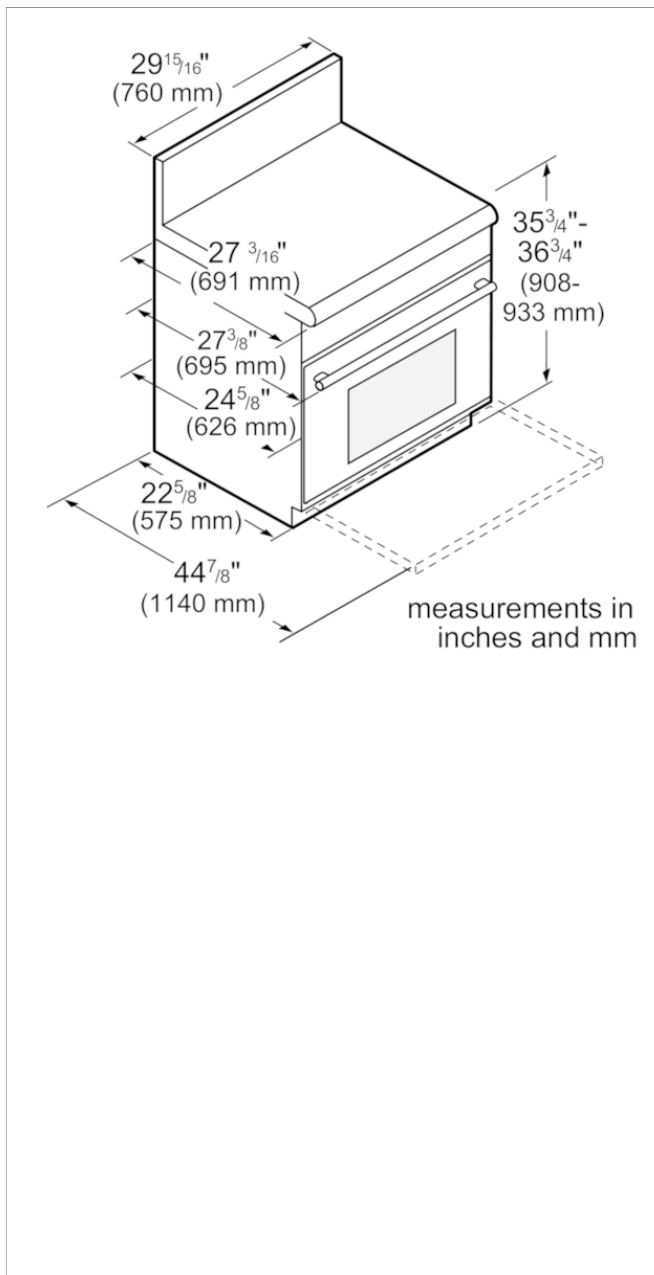

Product Features

Total number of cooktop burners: 4
 Cooking mode: 3rd element convection, Centre-area grill/broiler, Convection Bake, Convection Broil, Conventional heat, Roaster function, Selfcleaning pyrolytic, Special baking setting
 Integrated Cleaning system: Catalytic partial, Self Clean
 Type of control: Electronic
 Knob Material: Full metal
 Sealed Burners: Yes
 Number of Double grates: 3
 Bake Element Wattages cavity 1 (W): 2000
 Convection Element Wattages cavity 1 (W): 2750
 Number of gas burners: 4
 Location of 1st heating element: front left
 Power of 1st burner (BTU): 18000
 Location of 2nd heating element: center left
 Location of 3rd heating element: back left
 Power of 3rd burner (BTU): 15000
 Location of 4th heating element: middle back
 Location of 5th heating element: back right
 Power of 5th burner (BTU): 15000
 Location of 6th heating element: center right
 Safety device: automatic reignition, Electronic flame control, Overheating protection, Thermostat

Consumption and connection features

UPC code: 825225924821
 Product color:
 Gas type:
 Alternative gas type: Liquid gas 27,5 mbar (USA)
 Natural Gas Connection Rating (BTU): 66000
 Watts (W): 6400
 Current (A): 35
 Volts (V): 240/208
 Frequency (Hz): 60
 Approval certificates: CSA
 Required cutout size (HxWxD) (in): 30" width slide-in
 Overall appliance dimensions (HxWxD) (in): 35 7/8" x 29 15/16" x 24 5/8"
 Variable cooker height (in): 1"
 AHAM volume (of cavity) - cavity 1: 3
 Product packaging dimensions (HxWxD) (in): 49 1/4 x 43 1/2 x 40 3/8
 Net weight (lbs): 368
 Gross weight (lbs): 375

2019-04-22