

# T24UR910DS

## UNDER-COUNTER DOUBLE DRAWER REFRIGERATOR

MASTERPIECE® SERIES HANDLE



Also Available:  
 T24UR920DS – With Professional Series Handle  
 T24UR900DP – Custom Panel-Ready

### FEATURES & BENEFITS

- Customizable cooling modes—Fridge, Pantry and Bar
- SoftClose® drawers for ultra-smooth closing
- Customizable drawer dividers and shelving
- Quick Chill
- LED Lighting
- Drawer mats keep items from sliding and remove for easy cleaning
- Touch electronic controls for temperature management

### GENERAL PROPERTIES

SoftClose® Drawers	Yes
Lighting	LED Lighting
Customizable Aluminum Dividers / Shelving	Yes
Removable Drawer Mats	Yes
Full Extension Drawers	Yes
Drawer Open Alarm	Yes
Quick Chill	Yes
Touch Electronic Controls	Yes
STAR-K Certified Sabbath Mode	Yes

### CAPACITY

Total Capacity (cu. ft.)	5.0 cu. ft.
--------------------------	-------------

### TEMPERATURE RANGES

Refrigerator	33°F (0.5°C) to 58°F (14.5°C)
Pre-Set Cooling Modes	Refrigerator 37°F (3°C) Pantry 53°F (12°C) Bar 34°F (1°C)
Quick Chill	Refrigerator 33°F (0.5°C) for approximately 24 hours

### TECHNICAL DETAILS

Watts (W)	150 W
Current (A)	15 Amp
Volts (V)	115 V
Frequency (Hz)	60 Hz
Power Cord Length (in.)	60"
Plug Type	120V 3-Wire

### DIMENSIONS & WEIGHT

Appliance Dimensions (H x W x D) (in.)	34 1/4"* x 23 7/8" x 24"
Required Cutout Size (H x W x D) (in.)	35" x 24 3/16" x 24 9/16"
Net / Gross Weight (lbs.)	160 / 174 lbs.

### EFFICIENCY

ENERGY STAR® Qualified	Yes
Annual Energy Consumption	274 kWh

### WARRANTY

Limited, Entire Appliance, Parts and Labor on any Part of the Refrigerator that Fails Because of a Manufacturing Defect

2 Year

Limited Warranty for Sealed Refrigeration System\*; Parts and Labor

3rd to 6th Year

Limited Warranty for Sealed Refrigeration System\*; Parts Only

7th to 12th Year

\*Height adjustable + 1/2" (13 mm) with legs fully extended

\*\*Sealed refrigeration system includes compressor, evaporator, condenser, dryer / strainer and connection tubing

# T24UR910DS

## UNDER-COUNTER DOUBLE DRAWER REFRIGERATOR

MASTERPIECE® SERIES HANDLE



### DOUBLE DRAWER REFRIGERATOR PRODUCT DIMENSIONS

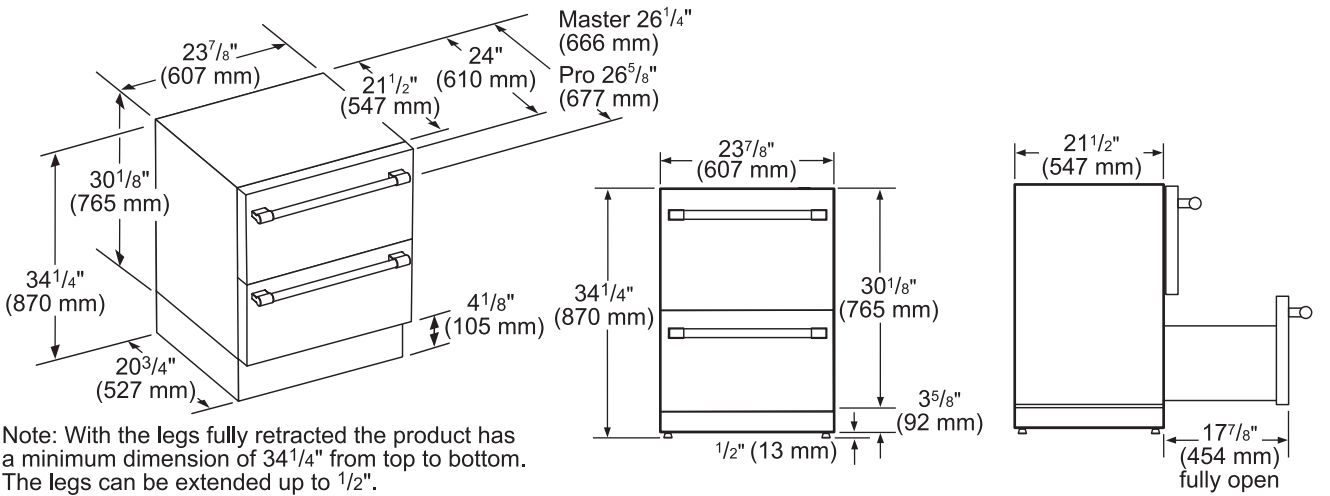

Note: With the legs fully retracted the product has a minimum dimension of 34<sup>1</sup>/<sub>4</sub>" from top to bottom. The legs can be extended up to 1<sup>1</sup>/<sub>2</sub>".

measurements in inches (mm)

### DOUBLE DRAWER REFRIGERATOR CUTOUT DIMENSIONS

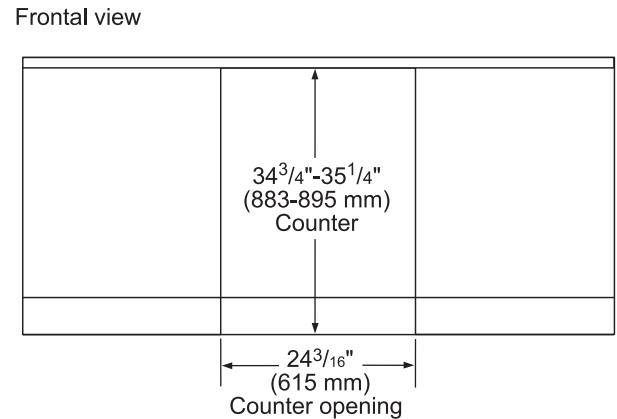
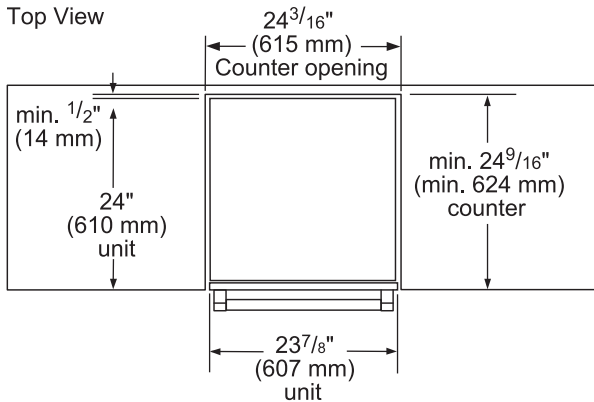

Thermador double drawer under counter top dimension. (Unit door flushed with the cutout)

measurements in inches (mm)

### DOUBLE DRAWER REFRIGERATOR SIDE-BY-SIDE INSTALLATION

### DOUBLE DRAWER REFRIGERATOR CLEARANCE DIMENSIONS

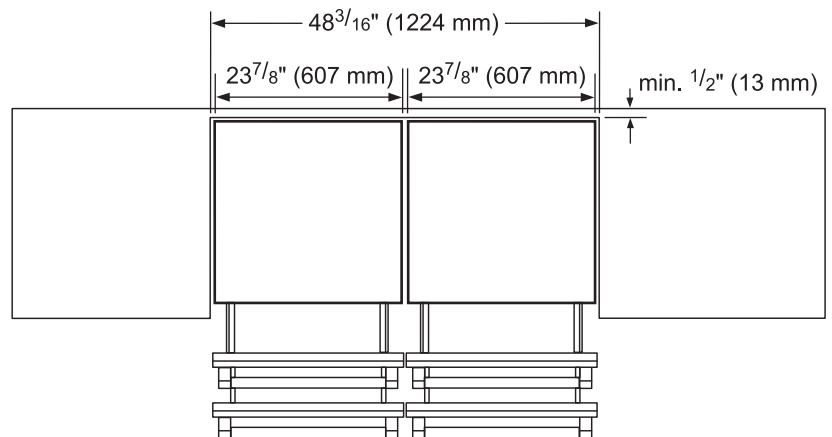
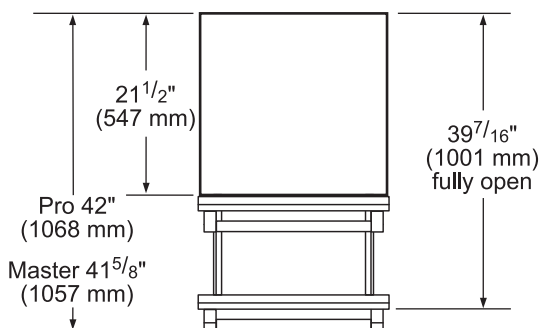

measurements in inches (mm)

# T24UR910DS

## UNDER-COUNTER DOUBLE DRAWER REFRIGERATOR

MASTERPIECE® SERIES HANDLE



### DOUBLE DRAWER REFRIGERATOR CUTOUT DIMENSIONS & ELECTRICAL LOCATION

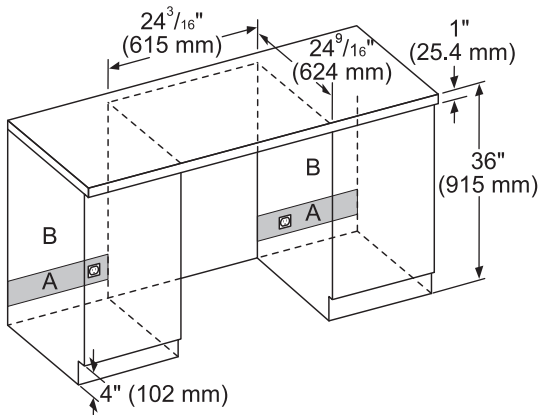

A:  
Recommended area for installation connection - a 2 1/2" (63 mm) diameter hole is recommended. Location of power cord at base of the appliance.

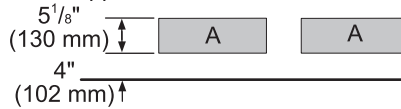

B:  
It is recommended that the water connection is placed adjacent to the installation cavity, so that it can be accessed without uninstalling the appliance.

For flush installation, recommend outlet and water connection to be placed to the side of the unit and not directly behind.

measurements in inches (mm)

### ACCESSORIES (OPTIONAL)

#### HANDLES

NOTE: Choose one handle for each glass door model, choose 2 handles for each double drawer model.



MS20HNDL20  
20-Inch Masterpiece® Series Handle

These warranties give you specific legal rights and you may have other rights that vary from state to state. Full warranty and limited warranty from date of installation. For complete warranty details, refer to your Use & Care manual, or ask your dealer.

Specifications are for planning purposes only. Refer to installation instructions and consult your countertop supplier prior to making counter opening. Consult with a heating and ventilation engineer for your specific ventilation requirements. For the most detailed information, refer to installation instructions accompanying product or write to Thermador indicating the model number. Specifications are correct at time of printing. Thermador reserves the right to change product specifications or design without notice. Some models are certified for use in Canada. Thermador is not responsible for products that are transported from the U.S. for use in Canada.