

Discover yours.

CONGRATULATIONS

We sincerely thank you for having granted Totem the special place in your living environment. These speakers are designed to redefine your musical understanding and open corridors of new experiences. We hope you not only enjoy but experience Totem as your guide to a new and rewarding listening environment! You will without a doubt experience a Totem moment.

OUR VISION

Created in 1987, Totem's mission is to develop loudspeakers capable of producing an involving performance that is true to the artist's intention. Our goal is to provide designs that are affordable, cosmetically timeless, and invoke an emotional response. Music, movies, TV, and video games are accurately rendered with a powerful focus that is yet soul stirring. Discover yours today.

Each speaker is a 'piece de resistance' that attests to the profound sound staging that can be reproduced by adaptable and innovative engineering. Listen and believe...

Totem Design Characteristics

Acoustic and aesthetic objectives of all Totem projects include:

- **Enormous sound and powerful bass from a smaller cabinet that can be conveniently integrated into any room.** These are often considered mutually exclusive characteristics.
- **Meticulously crafted for peak performance that lasts decades.** Designed obsolescence is rampant in consumer electronics, we favour longevity.
- **Aesthetics must be timeless and not trendy.** Totem speakers never goes out of style.

All Totem speakers are developed with these 4 design characteristics:

1-Proprietary scientific formulas are the foundation for the essence of Totem, eschewing outdated design guidelines and parameters.

2-Customized drivers, each quite unique and either manufactured by us or built to our exacting specs.

3-Hand made crossovers composed of the most exotic components and meticulously assembled.

4-Artisinal cabinet construction, including lock mitred assembly, interior and external veneers, Borosilicate in some cases, and graded MDF.

The 4 design characteristics produce the following 3 sonic signatures:

1- **Holographic imaging** for a three-dimensional, expansive soundstage.

2- **Bass impact** that is forceful and logic defying, considering the conveniently sized enclosure.

3- **Most importantly, the linear phase response** for uncanny, almost magical realism.

TABLE OF CONTENTS

Totem Limited Warranty	4
User Manual	5
Unpacking	5
Speaker Position	5
Set Up Chart	6
Connections	7
Troubleshooting Guide	7
Amplifier Distortion	8
Volume	8
Limits	8
Environmental Information	8
Decoupling Totem PLINTH	9
Decoupling Totem CLAWS	10
Articulating Claw and Skid Plate	12
Semi-spherical Decouplers	12
Mass Loading	13
Thoughts on grilles	14
Beak	15
Optional Accessories	16
Thank You	17

TOTEM LIMITED WARRANTY

Please register online at www.totemacoustic.com within two weeks of the purchase date. The Totem speakers must be purchased from a TOTEM AUTHORIZED DEALER.

Keep your original bill or receipt obtained from your Totem Authorized Dealer.

Retain the sturdy carton and all packing material; all warranty repairs are required to be shipped in their original packaging. This ensures no damage during transportation.

All Totem products are created with the utmost care and quality in mind. If ever a problem should arise, Totem's speakers are covered by a **five (5) year limited warranty**, (excluding subwoofers) starting from the date of purchase. The Totem limited warranty applies to products in normal home use only. The warranty is void if serial numbers have been altered or removed. The warranty is void if products show signs of abuse. The warranty is void if the speakers have been tampered with.

Totem speakers can require as little as 75 hours and as much as 300 hours of actual music playing time as a minimal break-in period. During this time, refrain from playing them at very loud levels. You will notice a definite gradual improvement in the cohesiveness of the music reproduction as this occurs.

We reserve the right to any future change or modification without notice. If you have any further queries or require any classifications, feel free to contact your Totem Authorized Dealer.



For further assistance, contact your TOTEM AUTHORIZED DEALER or visit the Support Section of the Totem website at www.totemacoustic.com/support.

USER MANUAL

Thank you for choosing Totem Acoustic. Please take the time to fully read this manual prior to beginning set-up. The manual will clearly guide you to achieve the best possible sound that these newly acquired Totem speakers can provide.

UNPACKING

Totem Acoustic keeps to a strict quality control regimen and all factory-sealed products leave our facility in perfect condition. If there are any damages visible or concealed that has occurred in handling it must be reported immediately to your Authorized Totem Dealer.

Carefully remove the speaker(s) from the box(es); take caution as the size often defies the actual weight. Save all custom cartons and packaging foam for future use.

SPEAKER POSITIONING

Totem produces speakers with great dispersion, both on the vertical and horizontal axis. They can be placed in extremely varied positions and still produce a large and accommodating, non-shifting soundstage. Keep in mind that a room with a variety of materials will deliver a much more harmonized sound. These speakers are of a superior design and will perform remarkably well in a variety of spaces. Particular care should be taken to ensure proper placement. Below are some guidelines for general in-room placement that can help optimize performance.

BOOKSHELF

Bookshelf speakers should be placed on appropriate stands, or shelves, at ear level or above. If they are placed extremely close to the ceiling, you can position them upside down, with the tweeter underneath the woofer. Totem speakers not only image in-between their individual positions but also towards the outside of their axis (both vertical and horizontal). In placing the Bookshelf speakers in room, one may optimize their performance by placing them closer to one another.

FLOORSTANDING

Our Floorstanding speakers create a three-dimensional, accurate soundstage without requiring any toe-in. If the distance between them is greater than 8 feet (2.5 m) and the room acoustics are having a substantial effect to the imaging, then you can experiment with angling them. Start by toeing-in one speaker slightly and then the other, if needed. Gradual experimentation is the key.

Totem generally recommends that you position bookshelf and Floorstanding speakers 12 in (30.5 cm) from the back wall and side wall to allow a better energy flow and cleaner bass response. Room Acoustics and associated electronics can dictate different placement so again, experimentation is the key. Consult the chart below for general guidelines. More information can be found on the Support page of our website. www.totemacoustic.com

SET UP CHART

Model	Placement from Rear Wall	Placement Distance Apart	Break-in Time
Rainmaker	1' - 3' / 30.48 - 91.44 cm	4' - 8' / 121.92 - 243.84 cm	70 - 100 hours
Sky	6" - 3' / 15.24 - 91.44 cm	2' - 8' / 60.96 - 243.84 cm	70 - 100 hours
Signature One	1' - 3' / 30.48 - 91.44 cm	4' - 12' / 121.92 - 365.76 cm	100-150 hours
Element Ember	6" - 3' / 15.24 - 91.44 cm	2' - 8' / 60.96 - 243.84 cm	200-300 hours
Element Fire	6" - 3' / 15.24 - 91.44 cm	2' - 8' / 60.96 - 243.84 cm	200-300 hours
Arro	6" - 3' / 15.24 - 91.4 cm	2' - 12' / 60.96 - 365.76 cm	100 - 150 hours
Sky Tower	9" - 3' / 22.86 - 91.44 cm	2' - 8' / 60.96 - 243.84 cm	70 - 100 hours
Hawk	1' - 6' / 30.48 - 182.88 cm	3' - 8' / 91.44 - 243.84 cm	60 - 80 hours
Forest	1' - 6' / 30.48 - 182.88 cm	4' - 12' / 121.92 - 365.76 cm	100-150 hours
Forest Signature	1' - 6' / 30.48 - 182.88 cm	4' - 12' / 121.92 - 365.76 cm	100 - 150 hours
Wind	3' - 7' / 91.44 - 213.36 cm	6' - 14' / 182.88 - 426.72 cm	200 - 250 hours
Wind Design	3' - 7' / 91.44 - 213.36 cm	6' - 14' / 182.88 - 426.72 cm	200 - 250 hours
Tribe Tower	4"-3' / 10.16 - 91.44cm	2'-15' / 60.1- 457.2	100-200 hours
Element Earth	6"-4' / 15.24-121cm, but varies based on electronics and room acoustics	2'-15' / 60.1-457.2cm, but varies based on electronics and room acoustics	200-300 hours
Element Metal	6"-4' / 15.24-121cms, but varies based on electronics and room acoustics	2'-15' / 60.1-457.2cm, but varies based on electronics and room acoustics	200-300 hours

CENTER CHANNELS

Our Center Channels are carefully voiced to seamlessly match the appropriate Mains. Please refer to our website www.totemacoustic.com for the appropriate center channel pairing. For optimal results Totem recommends positioning the Center Channel 20-30 in (50.8 - 76.2 cm) above the floor, equidistant between the Left and Right speaker.

CONNECTIONS

All connections should be made with the equipment turned off.

Totem delivers all speakers with jumpers installed. For a standard single wire connection simply leave the jumpers in place. Be certain to connect the positive red (+) terminal of the speaker to the positive red (+) output terminal on the amplifier. Be certain to connect the negative black (-) terminal of the speaker to the negative black (-) output terminal on the amplifier. The speakers will sound out of phase (bass loss and image distortion) if there is an error in your connection. Totem speakers can be bi-amped and bi-wired, please consult your amplifier manual for detailed instructions or contact your Totem Authorized Dealer.

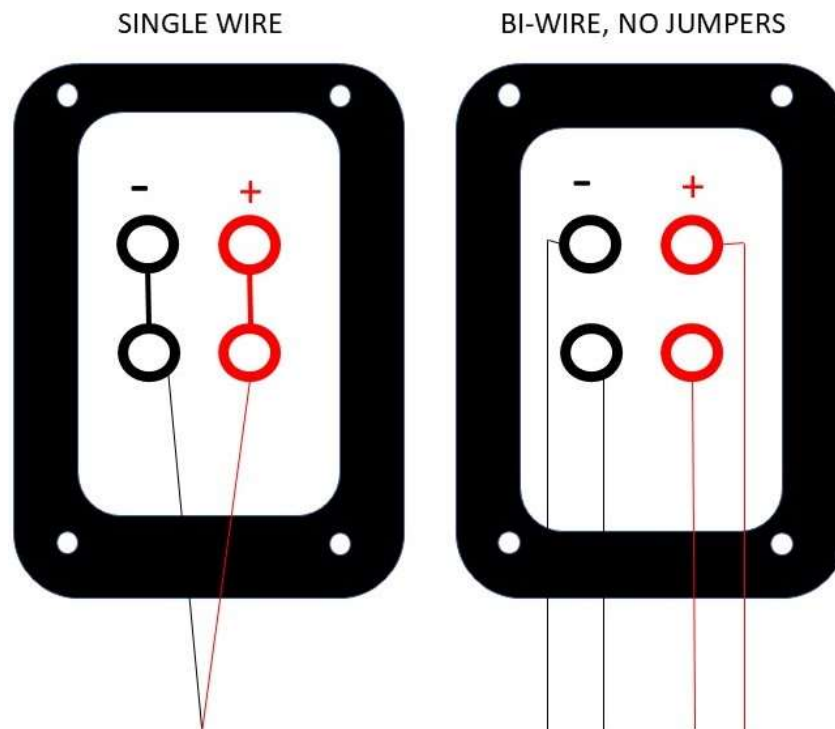

TROUBLESHOOTING GUIDE

No sound: Verify that your pre-amp and/or amplifier, and receiver are plugged into the AC PLUG and are turned on. Verify that the wall AC outlet is functional and that your system is not on mute.

Sound from one speaker only: Verify the balance control on your system. Swap speaker sides to verify if speaker is functional. Verify power cords on all sources. (Amplifier, preamp, receiver, CD, DVR)

Lack of bass or image: Verify the polarity of speaker connections.

AMPLIFIER DISTORTION

The most common source of speaker damage results from amplifier distortion. Your amplifier may run out of clean power upon listening at loud levels. A direct consequence of such an overuse is distorted power, producing a greater quantity of distortion than its rated output power. This provides a threat of damage to any loudspeaker.

The greater the amplifier power, the safer the loudness potential. A 50 watt/channel amplifier, if driven above this 50 watt/channel limit, will naturally produce multiplicatively more distortion than at 50 watts. A 120 watt/channel amplifier will have substantial distortion above 120 watts but will not allow any significant distortion below 100 watts. To conclude, more amplifier power provides cleaner power and less possibility for damage.

VOLUME

Volume controls on the amplifier/ receiver/preamplifier are very misleading. Please note that the volume control does not address power-output, but simply adjusts the audible level of music. It is the type of music being played that has an incidence on the amount of power used at a given volume level. Less dynamic music utilizes lesser amplifier power than more dynamic music does. With most music, the amplifier reaches its maximum power between the 11 and 1 o'clock position on the volume dial.

Distortion is inevitable when the amplifier is pushed above its rated output level, which may result in speaker damage. This occurs with any type of speaker. This type of damage constitutes abuse and may not be covered by warranty. Be attentive to the instant distortion commences, turning the volume control down to prevent speaker and/or amplifier damage.

LIMITS

Be wary of providing more power than is appropriate for your speakers and damaging them. Although a more powerful amplifier may provide better sound, it is very important to utilize speakers within their power-range rating to prevent damage.

ENVIRONMENTAL INFORMATION

All Totem products are designed to comply with international Restriction of Hazardous Substances (RoHS) and CARB certification.

DECOUPLING

Totem recommends decoupling the loudspeaker to break down cabinet resonance for optimum results. There are a variety of unique decoupling systems offered by Totem. To find the appropriate system, you must match your speaker to the correct system.

TOTEM PLINTH- Arro

List of Materials

Every Totem Plinth assembly pack includes:

- 2 wood-painted black plinths
- 8 screws
- 8 spikes and nuts
- 8 silicone washers
- 8 pcs of yellow adhesive

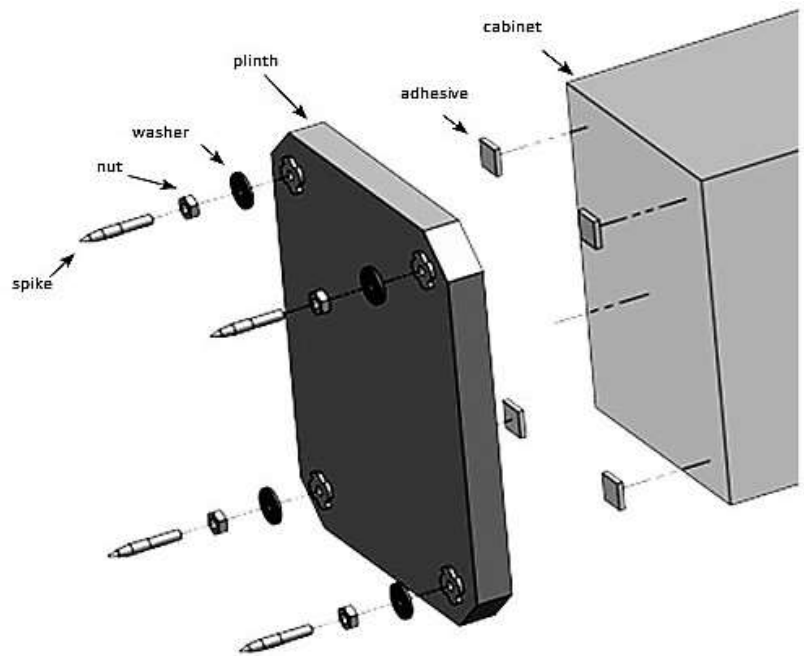

Thread a nut onto the spike. Next, slide a silicone washer into the spike assembly. Insert the assembly into the plinths. Repeat this procedure until all 8 spikes are fastened into the plinths. Once all the spikes and washers are installed level the plinth to the floor.

Precautions to protect the finish should be taken when placing the speaker on its head. Please use one of the packaging foam end caps to secure the speaker on its head. Once the adhesive has been set, place the speaker on the plinth squarely.

Apply firm pressure to secure the bond. TOTEM recommends that you leave both the speaker and plinth connected indefinitely.

Every assembly pack includes a yellow reusable adhesive which is separated into 8 units (4 per plinth). Separate 4 adhesive units and place them on the bottom of the speaker, 1 in (2.54 cm) from the edge of the speaker (the adhesive will spread out once loaded). **If the plinths need to be removed: Twist the plinths slowly in a clockwise fashion. Take note not to “pull” the plinth off, as this may cause damage to the cabinet.**

TOTEM CLAW

Included with Sky Tower, Hawk, Forest, Wind
 Can also be used on Arro (purchased separately)

The Totem Claw is a revolutionary decoupling system whose unique geometric shape allows them to break up surface standing waves and control resonances on any surface. Those used with the Hawk, Forest, and Wind are machined from solid aluminum, those on Sky Tower from a high density inert composite. Before installation you may want to locate the final resting place of the speaker. The speakers are predrilled to accept the Totem Claws. **A Robertson or Phillips screwdriver is necessary for this installation.**

LIST OF MATERIALS

Totem Claw assembly packages for Hawk and Forest includes:

- 6 Totem Claws
- 6 screws
- 6 ball bearings

Wind includes 2 of each



Claws for Sky Tower do not include nor require spikes or ball bearings. They have been designed and voiced for ideal performance without any additional accessory required. They are fitted with a 1/4" 20 thread insert should you desire to purchase spikes.

The larger hole is for the supplied screw, which attaches the Claw to the cabinet.

The smaller hole is the 1/4" 20-thread insert to accommodate optional spikes.



CLAW INSTALLATION INSTRUCTIONS

Start by positioning the speaker on the top portion of the cabinet. Take precaution to protect the finish by using the packaging foam end cap to secure your speaker prior to installation.

Insert a screw into a single Totem Claw and position the assembly (screw and claw) over the pre-drilled hole; the screw will serve as a guide to find the pre-drilled hole. The Totem Claws should be positioned on each rear side of the speaker and one centered in front.

Using the appropriate screwdriver or low speed drill, with proper bit, screw in the fastener carefully while firmly pushing the Totem Claw flush against the front speaker surface, making full contact with the wood surfaces. Repeat the procedure for all 3 Totem Claws and speakers. Position the speaker on its claws after finding the appropriate room location. Insert the self-centering ball bearing underneath the Totem Claw. The Claws can be used with or without the ball bearings depending on the floor surface.

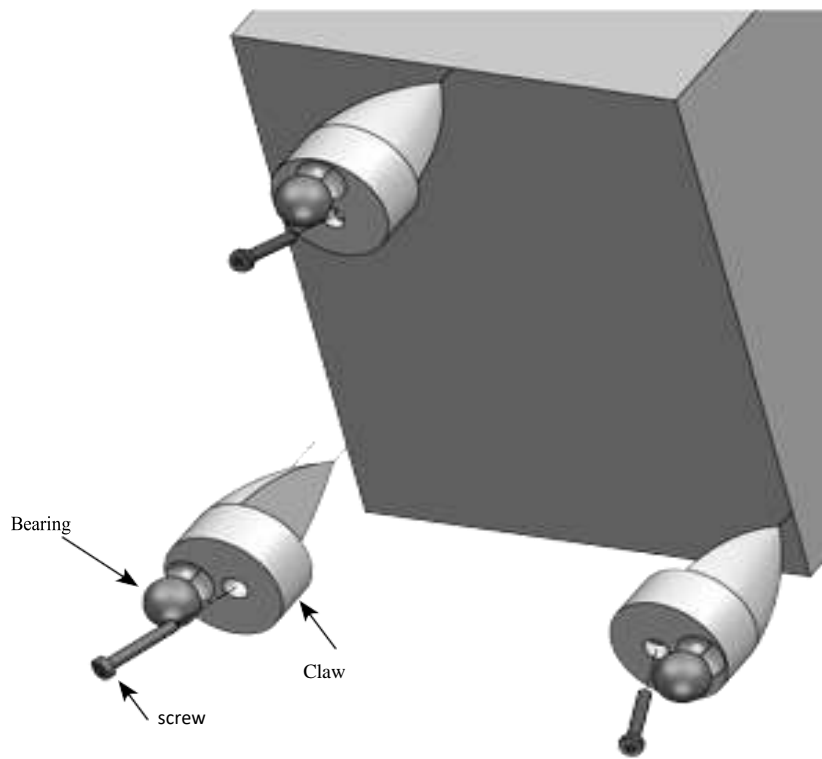

ARTICULATED CLAW AND SKID PLATE

(Included with Forest Signature, Wind Design, Element Earth, Element Metal)

This unique decoupling system consists of two components; the articulating claw which creates a rake, and the skid plate.

This unique claw can be adjusted to modify the angle of the cabinet rake to allow optimal bass loading and phase/space articulation. The aluminum plate including two integrated, formed feet at the base of the speaker, effectively eliminates resonances between the floor and speaker enclosure. Together, they perfect the phase linearity and allows the speaker to take full advantage of its bass and soundstage capability.



The Articulating claw consists of two pieces; the claw itself and a threaded insert.



The threaded insert fits into the base of the claw and can be adjusted as desired.

Follow the same procedures for installation as the Claws.

Position the skid plate with the protruding feet at the back of the cabinet and use the supplied hardware to attach it. Element includes rubber ball bearing for the feet of the skid plate.

SEMI-SPHERE DECOUPLERS

Included with Tribe Tower

Machined from solid aluminum, the Semi Sphere Decouplers are threaded to smoothly fit into the inserts at the bottom of the cabinet and the provided nuts allow for perfect leveling to any surface. The rounded surface prevents scratching like traditional spikes.



The base of the cabinet is fitted with a machined ¼" 20 thread insert to accommodate the decouplers.



The decouplers provide stability, and acoustic decoupling with a non-scratch form.

TOTEM MASS LOADING INSTRUCTIONS

Recommended for Arro, Sky Tower, Hawk, Forest, Forest Signature

Caution: Overloading tends to reduce overall image. Please experiment with small increments of loading to achieve optimal results.

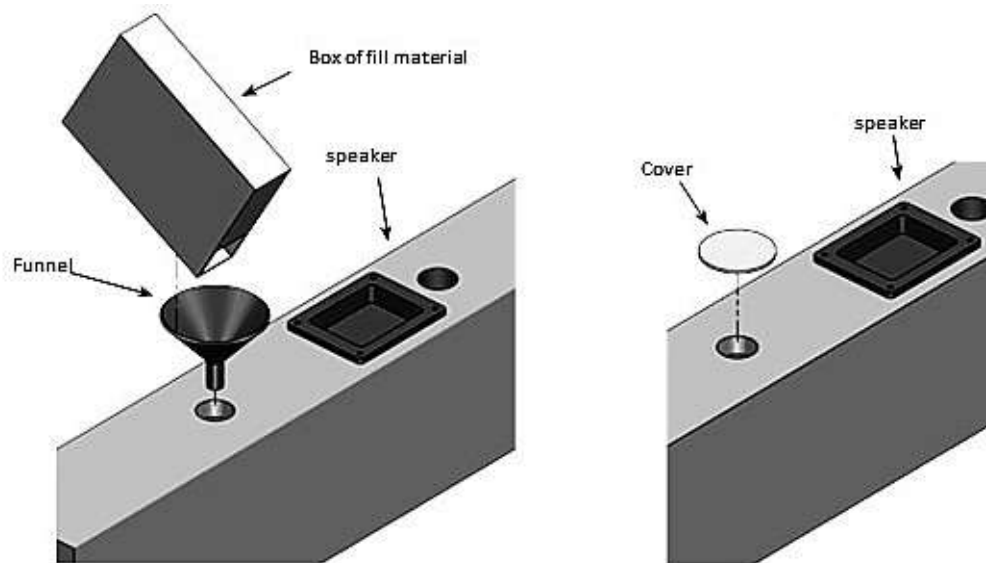

LOADING TOTEM SPEAKERS

1. Lay one speaker against a low piece of furniture (example: couch) with the speaker facing the ground. Take care not to crush the dome tweeter or scratch the finish. The packaging foam may also be used to secure the cabinet.
2. Fill only the lower opening, not the upper (Black plastic lined) cavity. The upper cavity is for bass reflex and air control and will cause damage to the speaker if filled.
3. Use a funnel or any device which will facilitate loading.
4. Peel off one of the transparent plastic mass loading covers, from the plastic backing. Two (2) mass loading covers are provided.
5. Apply it to the opening to seal the cavity. Repeat this procedure on the next speaker.

Note: Always remember to apply the plastic adhesive stopper to seal the cavity. To prevent damage, the speakers, should never be transported with mass inside. The cavity must be emptied prior to transport by using a shop vac and sealed thereafter using a sturdy tape to avoid any loose sand from migrating. Totem recommends the use of either: Kiln dried sand; Silica sand or lead shots.

OUR THOUGHTS ON GRILLS

Grills are optional on Rainmaker, Rainmaker Center, Model 1 center, Arro, Hawk, Forest, Forest Signature, Wind, Wind Design, Storm subwoofer, and Thunder Subwoofer.

All other Totem models come equipped with magnetically attaching grilles included in the box. This is a departure from our original practise as for years we did not include grilles and only made them available as an optional accessory. We firmly believe that our customized drivers are of the highest quality, the cabinet is a timeless design, and the combination provides an extremely appealing esthetic.

Most importantly however, therefore, are the micro details that are lost when a grille, no matter how supposedly acoustically transparent, is in place in front of the drivers. Totem's absolute dedication to phase consistency and subsequent holographic, almost interactive soundstage are slightly altered with attached grilles and while the effect is admittedly extremely small, it is not insignificant to us and probably not to you, a Totem owner.

Our intense listening sessions are conducted without a grille and we believe yours should as well. Only our architectural speakers are voiced with a grille in place because of the strong cosmetic preferences associated with their very specific application.

INSTALLING OPTIONAL GRILLES

For Forest, Forest Signature, Wind, Wind Design

These models have embedded magnetics, as do their optional grills as well. They are instantly easily attachable and removable.

For Rainmaker, Rainmaker Center, Arro, Hawk, Storm subwoofer, and Thunder Subwoofer.

The grills for these models come with male and female sets of Velcro circlets. Attach the male and female circlets to each other and apply them to the baffle. Position the grille over the speaker, making sure it is properly positioned and not blocking any driver. Gently apply pressure to affix the adhesive backed portion of the Velcro circlets to the speaker cabinet.

MORE TOTEM PERFORMANCE ENHANCING ACCESSORIES

Totem offers a selection of accessories that can further enhance your enjoyment of our speakers. Some have been designed for speakers, some for the associated electronics, but all help enrich the listening experience and help get the most musical satisfaction from our speakers.

THE BEAK

The “Beak” was developed to control parasitic vibrations that occur on top of a speaker cabinet. These resonances interfere with speaker performance, specifically the waveform symmetry emitted by tweeters. Implementing a Beak on any speaker can effectively control and provide a better interaction between speaker, tweeter and housing.

Careful thought and research were poured into the development of the Beak. Its precisely defined contour was carefully designed; if any of its properties were altered, it would impact the flux created within and render the unit ineffective.

The Shape

The “Beak” is milled in a prescribed form, which controls resonance and directs emanation. These distortions occur within a strict range. The Beak can channel common distortion and move it through its cavity to the discharge point on top, hence its shape and name. As the beak on a bird or whale channels sound, this Beak channels the negative effects of dynamic speaker housings.

Mass and Detail

The mass of the Beak is crucial to proper holography and image integration. In addition to the proper size and curve ratio, tests were done to determine the texture on the surface of the Beak. The spacing of the micro ribs increases from the bottom part to the peak. In fact, the line structure (micro ribs) controls the velocity at which the Beak dissipates distortion, helping the tweeter extend its range. This surface texture helps alter frequency and phase, allowing you to lock in a proper height and correct three-dimensional image.



Placement

The placement on smaller speakers is usually towards the outer front corner of a speaker pair. If one looks at the top of the “Arro” (our smallest surface area speaker), the placement is up front toward the outside. On larger speakers, a proper location must be derived. Experimentation is the key to determining the proper location.

Specs

The high frequency difference when using the “Beak” is measurable and quite apparent. The tweeter generally has better linearity in the 8 kHz to 20 kHz range. Therefore, better staging and imaging is evident. At the crucial crossover point, frequency dips both on and off axis can be alleviated by as much as 1.5dB. Outcome: better harmony between woofer and tweeter, resulting in enhanced speed, impact and transients.



CLAWS

The same Claws included with the Hawk and Forest are available to be purchased separately and added to any speaker and provide noticeable sonic improvements. The Totem Claw is a revolutionary decoupling system whose unique geometric shape allows them to break up surface standing waves and control resonances on any surface.



TRESS SPEAKER CABLES



A twisted pair of 14-gauge, multi strand, linearized oxygen-free silver-plated conductors coated in black and white Teflon. Dielectric shielding makes it impervious to damage and oxidization. Tress can be run long distances -in-wall and around room and are thin enough to be easily accommodated. It provides great extension in both high and low frequencies, excellent spatial ability, has no capacitance buildup, and is FT4 rated. It is one of the best performers out there, yet remarkably economical.

Tress is also available in a bi-wire format, featuring a single stranded pair to a double stranded pair. These cables also include 12 WBT terminals.



SINEW INTERCONNECT

The Sinew offers an unparalleled medium across which a signal can ride and pass through with no added coloration or loss of any kind.

URTH POWER BLOCK

The ultimate power block, the URTH will lower the noise floor, smoothen the power, and satisfy the most demanding power requirements. Amplifiers, subs, cross overs or any audio component will benefit from URTH's quality components.



URTH POWER CORD

When the AC flows freely and cleanly, and advanced isolation technology is used to thwart EMI/RFI, the rest of the chain clearly benefits. Urth Power Cord adds liveliness to the presentation and accents music in subtle but noticeable ways.

THANK YOU

We sincerely hope you enjoy your Totem speakers and greatly appreciate your patronage. New products are consistently being developed so be sure to periodically visit your authorized Totem dealer or our website to keep informed on everything Totem has to offer.

<https://totemacoustic.com/en/>

If you already purchased a Totem product, we very much would appreciate if you took the time to register your product online. Product registration leads to quicker assistance and more efficient support in the rare case that your speaker should have a problem. This can be done quickly and easily in the support section of our site:

<https://totemacoustic.com/en/support/product-registration>

Follow and Like us on Facebook:

<https://www.facebook.com/totemacoustic/>

If you require additional information or further assistance on the Totem you've discovered, contact your TOTEM AUTHORIZED DEALER or visit the Support Section of the Totem website at:

www.totemacoustic.com/support



www.totemacoustic.com