

Diagrams

◀17"▶

Wall Mounting

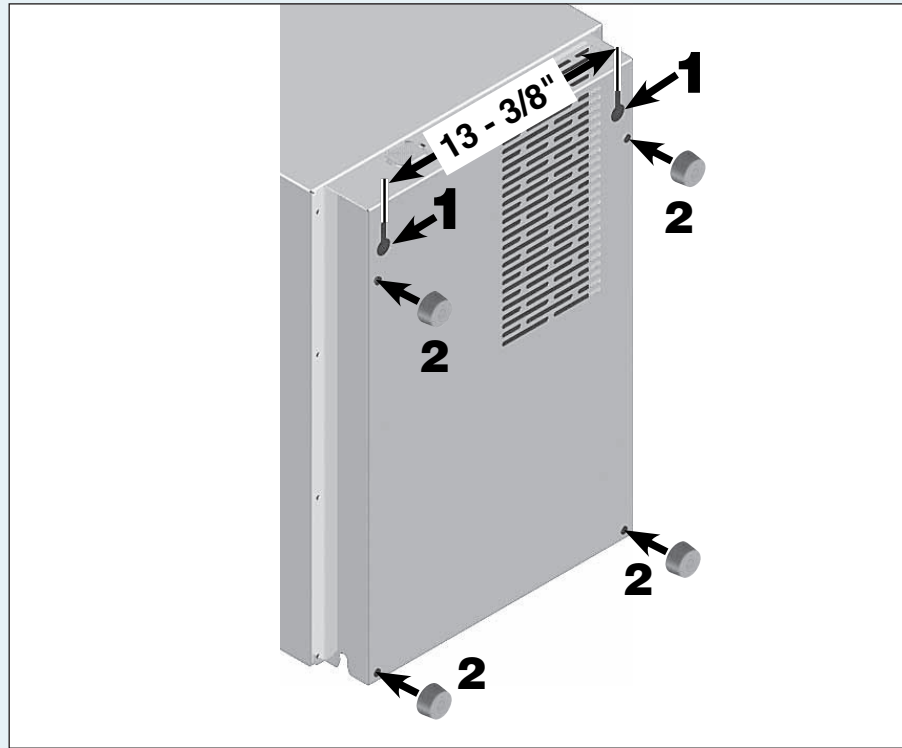

The appliance can be wall-mounted. There are two mounting holes 1 at the back of the appliance.

CAUTION

Make sure the wall and fastenings can withstand the weight of the appliance when fully loaded. The empty appliance weighs 68.4 lbs.

IMPORTANT

To ensure sufficient ventilation through the ventilation slots, the four wall spacers 2 must always be inserted, regardless of whether the appliance is wall-mounted or standing on the floor against a wall.

Simply insert the spacers in the openings provided.

Unit Dimensions

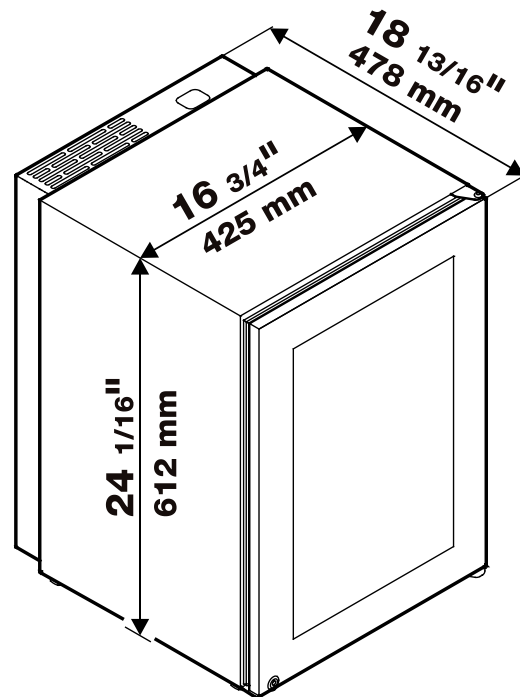

Subject to modification. For up-to-date information, visit home.liebherr.com.



WS 1200
Design & Lifestyle

 GERMAN
ENGINEERING

LIEBHERR
Quality, Design and Innovation

Design & Lifestyle

◀17"▶

Liebherr's **WS 1200** offers premium wine storage in an attractive package to fit within any setting. This tabletop wine cabinet holds up to 12 Bordeaux bottles on solid beech wood shelving, and includes a drawer to store wine accessories, chocolates, or candies.

The temperature of the cabinet can be set between 41°F and 68°F, making the **WS 1200** suitable for storing reds, whites, and champagnes. Energy efficient LED lighting can be controlled with a dimming function creating the perfect atmosphere without affecting the temperature of the wines.



Design & Lifestyle

Energy consumption (kWh/y)	310
Estimated Yearly Energy Cost in US \$*	–
Sound rating dB(A)**	41
Total capacity cu.ft. (l)	1.3 (38)
Max. No. of Bordeaux bottles (0.75 l)	12
Number of shelves	3
Shelf material	Beech wood shelves
Electronic control	LCD temp. display, touch electronic
Temperature range °F (°C)	+41°F to +68°F (+5°C to +20°C)
Temperature zones	1
Interior light	LED lighting permanently on, dimmable
Door alarm	acoustic
Activated Charcoal filter	yes
Door type	Glass door with stainless steel frame and SmartSteel
Integrated lock	yes
Door hinges	right
Product dimensions (H/W/D) in. (cm)	24 1/8" / 16 3/4" / 18 7/8" (61.2/42.5/47.8)
Cut out dimensions (H/W/D) in. (cm)	26" / 17" / 19" (66/43.1/48.2)
Net weight lbs. (kg)	66.1 (30.0)
Voltage V/Hz	115/60

WS 1200 GrandCru



* Estimated energy cost will depend on utility rates and use. Estimated energy cost based on a national average electricity cost of 12 cents per kWh.

** Noise output – according to EN 60704-3.

Features

◀17"▶



German Engineering: Our superior products offer premium quality, cutting edge design, and innovative features that best fit your lifestyle. The use of high quality materials, perfectly detailed finishes, and elite cooling components are combined with the latest production processes, resulting in an outstanding cooling product.

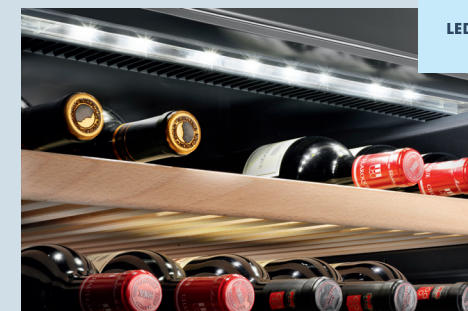

LED Ceiling Light: The energy efficient LED ceiling light not only emits virtually no heat for the optimal storage of wines, but is dimmable for a pleasant ambient light within the cabinet, as well as a cool glow for the room.



Integrated Lock: A sturdy lock protects your fine wine collection.



SmartSteel: Available on select freestanding/semi built-in models, SmartSteel significantly reduces the visibility of fingerprints and is very easy to clean and scratch resistant. All that is required to maintain this beautiful exterior is the wipe of a clean dry or damp cloth.



Activated Charcoal Filter: Optimum air quality is guaranteed in Liebherr wine cabinets thanks to the easy-to-replace FreshAir activated charcoal filter, which purifies incoming air, while filtering out damaging odors.



Alarm: Liebherr wine cabinets are equipped with a trustworthy alarm system which alerts the owner if the door has been left open, or if there are temperature changes.



Touch Control: The electronic touch system allows temperatures to be set to the exact desired degree, from 41°F to 68°F. Temperatures are clearly displayed on the LCD display for accurate readings of your desired settings.



UV Protection: In order to minimize the exposure of light which can damage the maturity of a wine, Liebherr wine cabinets are fitted with special UV-resistant insulated glass, simultaneously protecting and presenting your finest wines.



Compressors: Specially developed, exceptionally low-vibration compressors prevent tannins from settling, allowing wines to mature properly.