

ID-24FI



FEATURES

Ready to be fitted with custom panels and handles to blend with cabinetry

Automatic ice maker with "max ice" feature

Smart-touch controls for streamlined access to more settings

Soft-on LED lights for varying degrees of brightness

Soft-close doors and drawers

Rigorously tested in our U.S. manufacturing facilities to ensure decades of use

Exceptional 24/7 support from Madison, WI-based Customer Care team

ACCESSORIES

Dual Installation Kit

Reduced Toekick Divider

Stainless Steel Pro Handles

Stainless Steel Tubular Handles

Stainless Steel Drawer Panels With Pro Handles - 4" Toe Kick

Stainless Steel Drawer Panels With Pro Handles - 6" Toe Kick

Stainless Steel Drawer Panels With Tubular Handles - 4" Toe Kick

Stainless Steel Drawer Panels With Tubular Handles - 6" Toe Kick

Stainless Steel Dual Installation Kickplates

Accessories are available through an authorized dealer.
For local dealer information, visit subzero-wolf.com/locator.

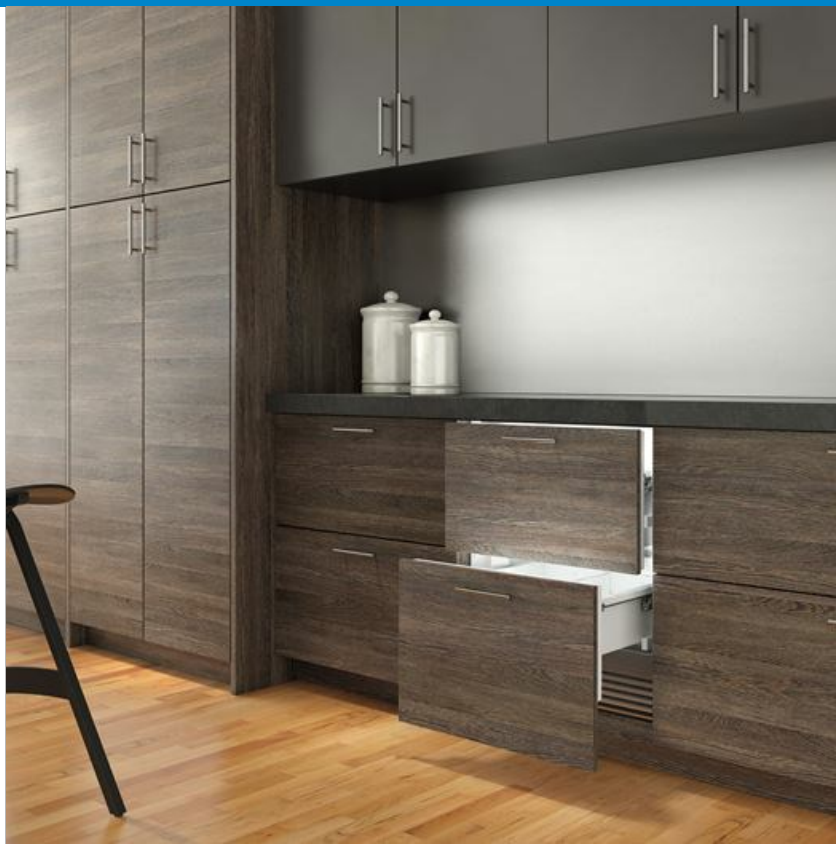

HANDLE ACCESSORIES

PRO



TUBULAR



PRODUCT DETAILS

FREEZER

- Adjustable drawer dividers
- Automatic ice maker
- Removable ice container

PRODUCT SPECIFICATIONS

Model	ID-24FI
Dimensions	24"W x 34 1/2"H x 24"D
Drawer Clearance	18 3/8"
Weight	170 lbs
Freezer Capacity	3.8 cu. ft.
Electrical Supply	115 VAC, 60 Hz
Electrical Service	15 amp dedicated circuit
Receptacle	3-prong grounding-type

ELECTRICAL

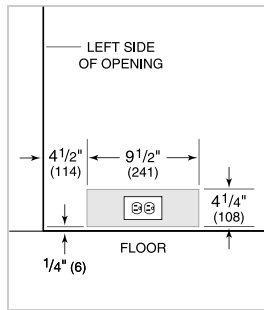

PLUMBING

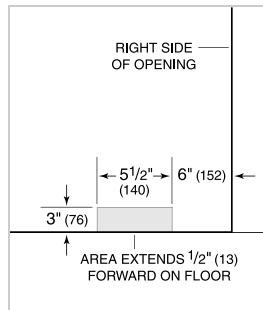

PANEL SPECIFICATIONS For complete panels specifications including width/height, weight requirements and thickness requirements visit subzero-wolf.com/reveal.

NOTE: Dimensions in parenthesis are in millimeters unless otherwise specified

INTERIOR VIEW

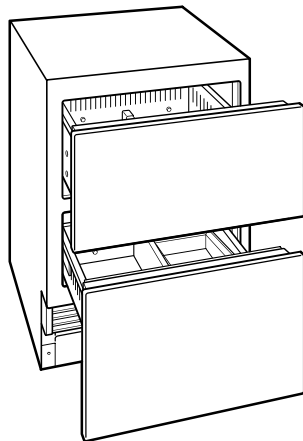

This illustration is intended for interior reference only and may not represent the exterior of the model being specified.

DIMENSIONS

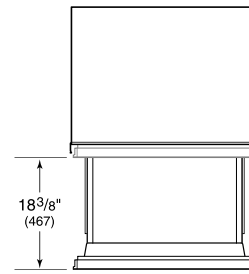
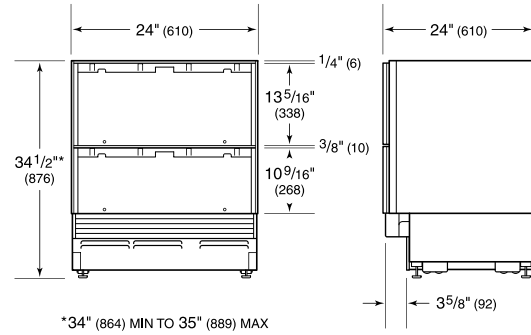

STANDARD INSTALLATION

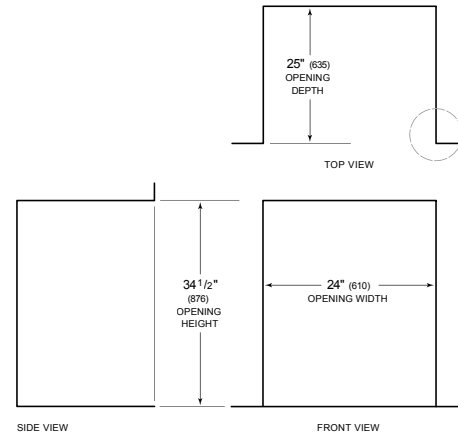

NOTE: 3 1/2" (89) finished returns will be visible and should be finished to match cabinetry

