

Diagrams

◀30"▶

Unit Dimensions

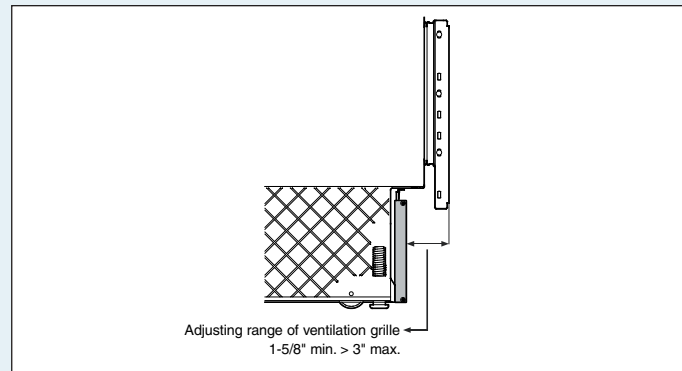
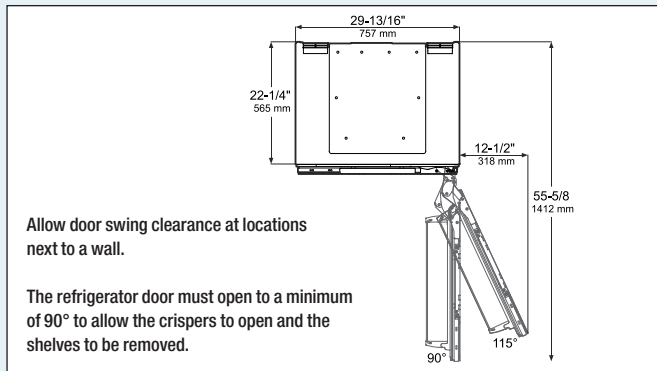
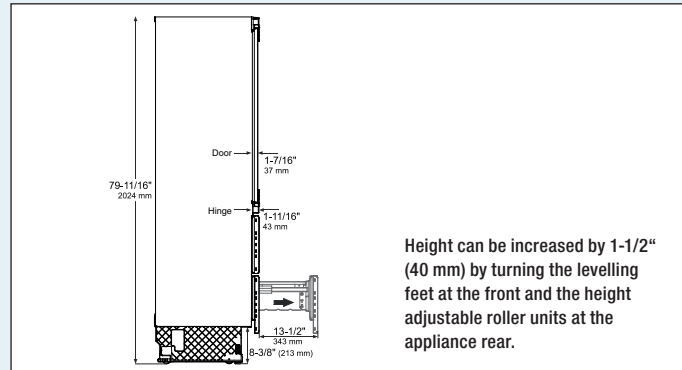
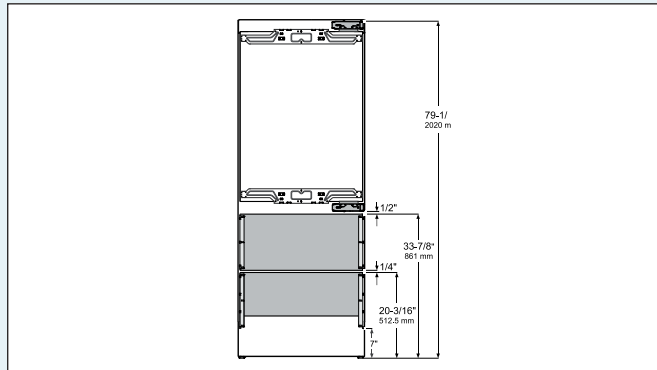

Panel Dimensions

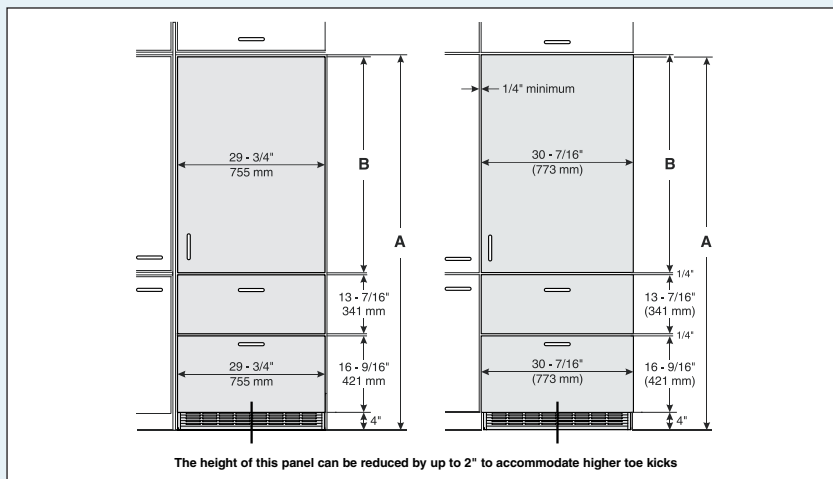

Minimum panel thickness is 5/8" (16 mm).

Maximum panel thickness is 1-1/2" (38 mm).

Maximum weight of the refrigerator panel is 60 lbs (27 kg).

Maximum weight of each freezer panel is 26.5 lbs (12 kg).

Cabinet opening A	Cabinet opening B
80"	45-1/4" (1150 mm)
84"	49-1/4" (1251 mm)"

Minimum panel thickness is 5/8" (16 mm).

Maximum panel thickness is 1-1/2" (38 mm).

Maximum weight of the refrigerator panel is 60 lbs (27 kg).

Maximum weight of each freezer panel is 26.5 lbs (12 kg).

Cabinet opening C	Cabinet opening D
80"	45-3/4" (1162 mm)
84"	49-3/4" (1264 mm)"

Cabinet Opening Dimensions

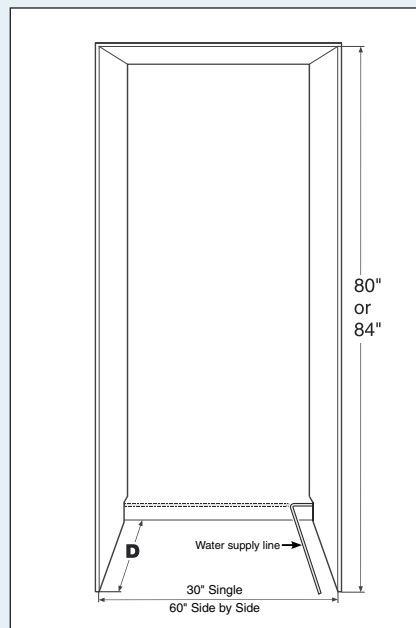

Inset cabinet Depth D	Inset cabinet Depth D
24" + panel thickness	24"

IMPORTANT
Factory available stainless steel panels are designed for an inset installation only and require a cabinet / gable depth of 24 - 3/4".



Liebherr HC 1550
Fully Integrated/Seamless



LIEBHERR
Quality, Design and Innovation

Fully Integrated/Seamless

◀30"▶

The **HC 1550** model is perfect for a seamless design because it is cleverly concealed behind cabinet doors. With a fully integrated door-on-door system that incorporates strong hinges for a convenient closing of doors even when fully loaded. Double freezer drawers mounted on smooth telescopic rails offer more than 4 cubic feet of storage space and the drawer system offers convenient handling and viewing of food stored. The automatic IceMaker which is permanently plumbed in and an integrated water filter with activated charcoal provides just the right supply of perfect crescent ice.



Fully Integrated/Seamless

Energy consumption

in 365 days kWh
Estimated Yearly Energy Cost in US \$

Capacity

Total capacity cu.ft. (l)
Refrigerator comp. cu.ft. (l)
NoFrost Freezer comp. cu.ft. (l)

Shipping weight lbs. (kg)

Climate rating

Sound rating dB(A)

Ice cube output lbs. (kg) / 24h

Ice cube stock lbs. (kg)

Door hinges

Outside dimensions

in inches (cm) H/W/D

Cut out dimensions

in inches (cm) H /W/D

Energy supply

Voltage V/Hz

HC 1550 Premium



507
61*
14.1 (400)
9.8 (278)
4.3 (122)
350.5 (159)
SN-T
—
3.1 (1.4)
7.9 (3.6)
right
79 13/16"/29 13/16"/24 1/16" (202.7/75.7/61)
80"/30"/min. 24" (203.2/76.2/min. 61)
115/60

Features

◀30"▶



German Engineering: Our superior products offer premium quality, cutting edge design and innovative features that fit your busy lifestyle. Exclusive components and materials, along with the latest production processes, ensure energy efficiency and performance for years to come.



Energy Star: Liebherr refrigerators help produce less energy waste and greenhouse gas emissions with the goal of having the least damaging effect on the environment, while offering solutions that help consumers conserve energy.



Duo Cooling

DuoCooling: The dual refrigeration system creates optimal conditions in both the refrigerator and freezer which lengthens the shelf life of food items for a healthier lifestyle. This technology also preserves the flavor and texture of foods since there is no transfer of unwanted air, moisture or food aroma between the two compartments.



SuperCool/SuperFrost: Simply quick chill and/or freeze fresh groceries to preserve optimum freshness and seal in flavors, textures as well as maintain essential vitamins and minerals.



Super Quiet

SuperQuiet: Noise is kept to a minimum with virtually silent, speed controlled compressors and a low-noise cooling circuit; while also ensuring exact performance, energy efficiency and SuperQuiet operation.



Electronic Control

Electronic Display: Our intuitive electronic touch control panel ensures all functions are easy and convenient to use as well as guarantees that the settings selected remain accurate and constant.



Glass Line

GlassLine: The elegant yet tough GlassLine shelves are scratch resistant and easy to clean as well as dishwasher safe. The space-saving shelves are designed for organization and are completely adjustable to suit your needs and the contents of the refrigerator. Additionally, the lighting shines through for a brighter interior.



LED

LED: The LED lighting housing is integrated into the side of the inner compartment and its central position provides optimal illumination. Flush integration guarantees a greater net capacity and more storage space.



Transparent vegetable bins: Transparent vegetable bins provide plenty of space for organizing fruit and vegetables. In addition, they are easy to clean.

* Energy Cost will depend on utility rates and use. Estimated energy cost based on a national average electricity cost of 12 cents per kWh.

** Noise output – according to EN 60704-3