

PRD366JGU 36-INCH DUAL-FUEL PRO GRAND® RANGE

PROFESSIONAL SERIES, COMMERCIAL-DEPTH, PORCELAIN COOKTOP SURFACE



FEATURES & BENEFITS

- ★ - Patented Pedestal Star® Burner with QuickClean Base® designed for easy surface cleaning and superior heat spread for any size pan
- ★ - Powerful 22,000 BTU (NG) burner (front right)
- ★ - Precision simmering capabilities as low as 100°F (375 BTU) with 4 ExtraLow® Simmer burners
- ★ - SoftClose® hinges for ultra smooth closing of the oven door
- ★ - Superfast 2-hour self-clean mode—fastest in the industry

TECHNICAL DETAILS

Circuit Breaker (A)	40 A
Volts (V)	240 / 208 V
Frequency (Hz)	60 Hz
Plug Type	No Plug
Power Cord Length (in)	Purchase Separately
Energy Source	Gas and Electric
Gas Type	Natural Gas 15 mbar (USA)
Alternative Gas Type	Liquid Gas 27.5 mbar (USA)

SEE PAGE 2 FOR OPTIONAL ACCESSORIES

GENERAL PROPERTIES

Oven Capacity	5.7 cu. ft.
Cooking Modes - Main / Large Cavity	
Bake, Convection Bake, Broil, Convection Broil, Roast, Convection Roast, Self Clean, Keep Warm	
Cooking Modes - Small Cavity	N/A
Additional Features	
Meat Probe, Sabbath Function, Cook Timer, Kitchen Timer	
Cleaning Type	Self Clean
Type of Grate	Continuous Cast Iron
Controls	Metal Knobs and LCD Display
Warming Drawer	No
Sealed Burners	Yes

OVEN PERFORMANCE

Bake Power	2,000 W
Broil Power	4,000 W
Convection Power	2,750 W

BURNER PERFORMANCE

Total Number of Cooktop Burners	6
Power of Front Left Burner BTU	18,000 and XLO (NG)
Power of Back Left Burner BTU	18,000 and XLO (NG)
Power of Back Center Burner BTU	18,000 (NG)
Power of Front Center Burner BTU	18,000 (NG)
Power of Center 12" Electric Griddle (W)	N/A
Power of Center 12" Electric Grill (W)	N/A
Power of Far Right 12" Electric Griddle (W)	N/A
Power of Back Right Burner BTU	18,000 and XLO (NG)
Power of Front Right Burner BTU	22,000 and XLO (NG)

DIMENSIONS & WEIGHT

Overall Appliance Dimensions (HxWxD) (in)	35 7/8"–36 3/4" x 35 15/16" x 28 3/4"
Required Cutout Size (HxWxD) (in)	35 7/8"–36 3/4" x 36" x 24"–25 1/8"
Adjustable Range Height (in.)	7/8"
Net Weight (lbs)	360 lbs

ACCESSORIES (INCLUDED)

1 X Nozzle Set for Liquid Gas, 3 X Telescopic Rack, 1 X Temperature Sensor, 1 X Island Trim, 1 X Broiler Pan

WARRANTY

Limited Warranty, Entire Appliance, Parts and Labor	2 Year
---	--------

PRD366JGU

36-INCH DUAL-FUEL PRO GRAND® RANGE

PROFESSIONAL SERIES, COMMERCIAL-DEPTH, PORCELAIN COOKTOP SURFACE



ACCESSORIES (OPTIONAL)



PAGRIDDLE
Griddle



PA12CHPBLK
12" Cutting Board



PWOKRINGHC
Wok Ring



PA36JLBG
9" Low Backguard



PA36JTKG
Toekick



PAKNOBLUNG
Blue Knob Pro Grand Kit

36-INCH RANGE AND CUTOUT DIMENSIONS

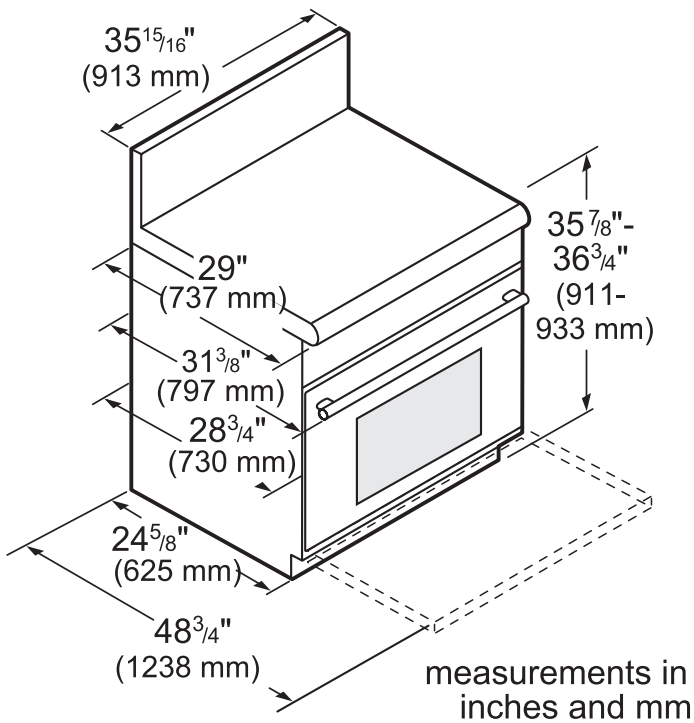

PRD366JGU
36-INCH DUAL-FUEL PRO GRAND® RANGE
 PROFESSIONAL SERIES, COMMERCIAL-DEPTH, PORCELAIN COOKTOP SURFACE



36-INCH RANGE CUTOUT DIMENSIONS

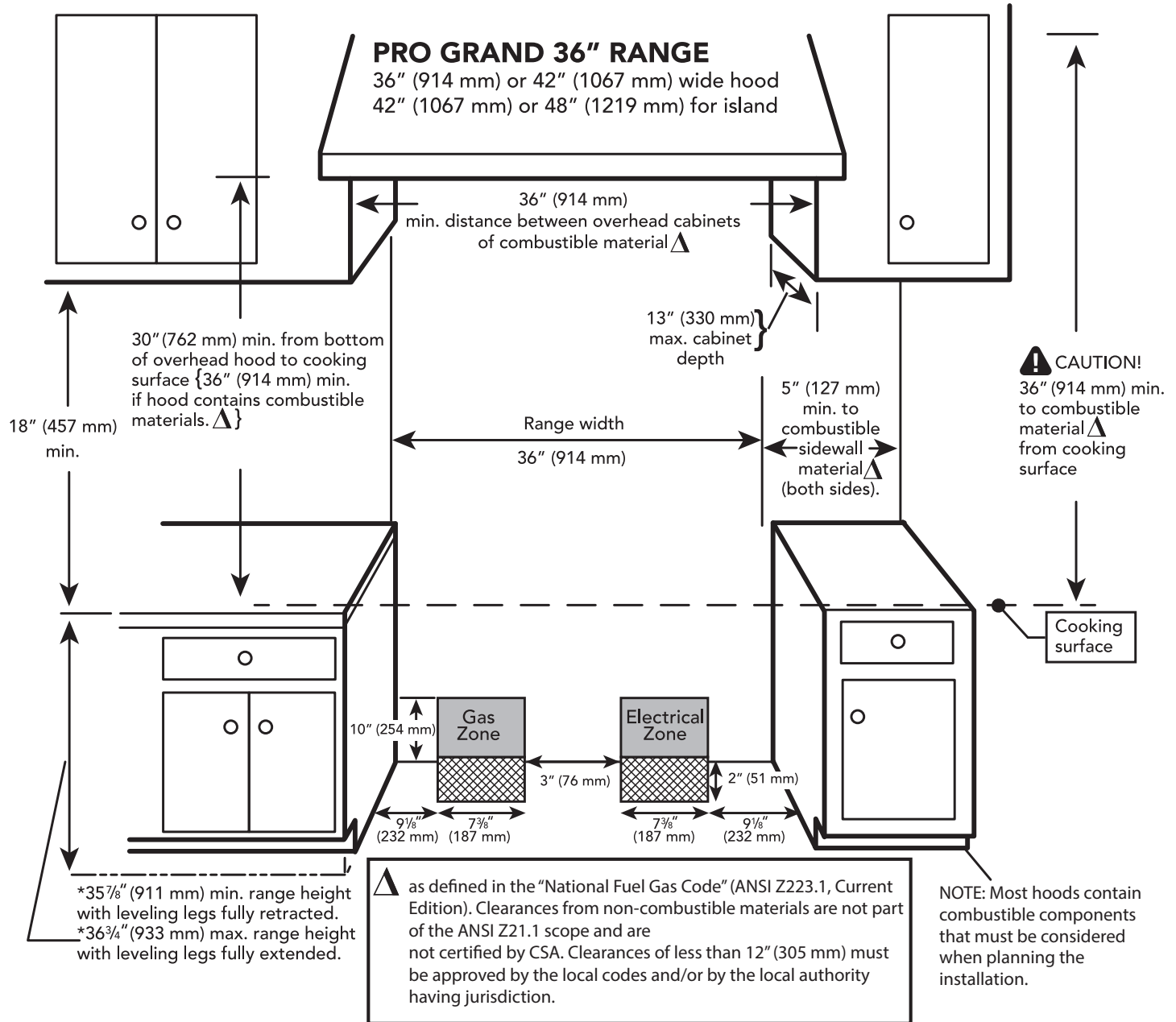

PRD366JGU
36-INCH DUAL-FUEL PRO GRAND® RANGE
 PROFESSIONAL SERIES, COMMERCIAL-DEPTH, PORCELAIN COOKTOP SURFACE



36-INCH RANGE DIMENSIONS AND CLEARANCE REQUIREMENTS WITH "LOW BACK"

NOTE: A 36-inch minimum clearance is required between the top of the cooking surface and the bottom of an unprotected cabinet. A 30-inch clearance can be used when the bottom of the wood or metal cabinet is protected by not less than 1/4 inch of a flame retardant material covered with not less than No. 28 MSG sheet steel, 0.015 inch (0.4 mm) thick stainless steel, 0.024 inch (0.6 mm) aluminum, or 0.020 inch (0.5 mm) thick copper.

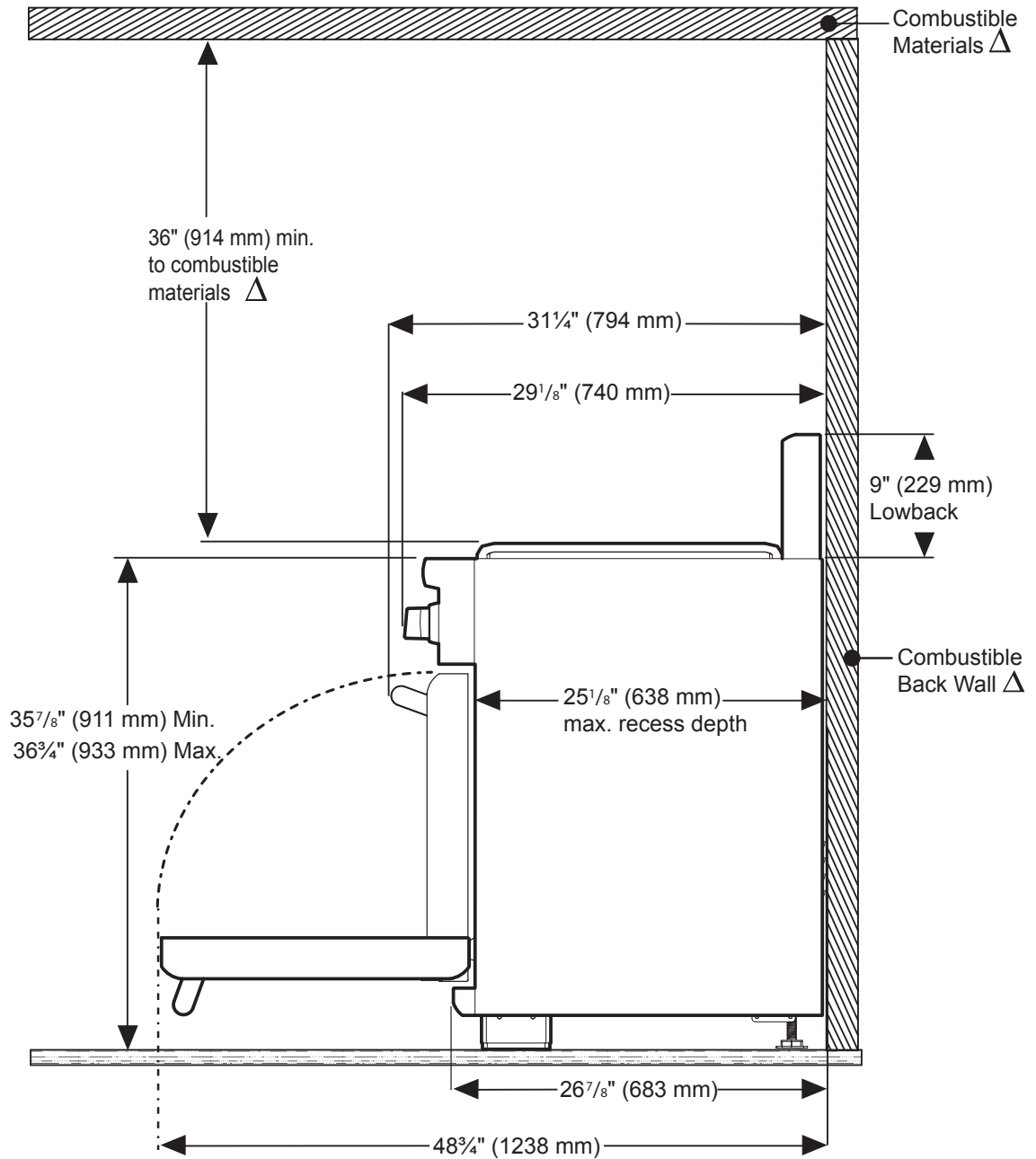

△ As defined in the "National Fuel Gas Code" (ANSI Z223.1, Current Edition). Clearances from non-combustible materials are not part of the ANSI Z21.1 scope and are not certified by CSA. Clearances of less than 12" (305 mm) must be approved by the local codes and/or by the local authority having jurisdiction.

PRD366JGU
36-INCH DUAL-FUEL PRO GRAND® RANGE
 PROFESSIONAL SERIES, COMMERCIAL-DEPTH, PORCELAIN COOKTOP SURFACE



36-INCH RANGE DIMENSIONS AND CLEARANCE REQUIREMENTS WITH "FLUSH ISLAND TRIM"

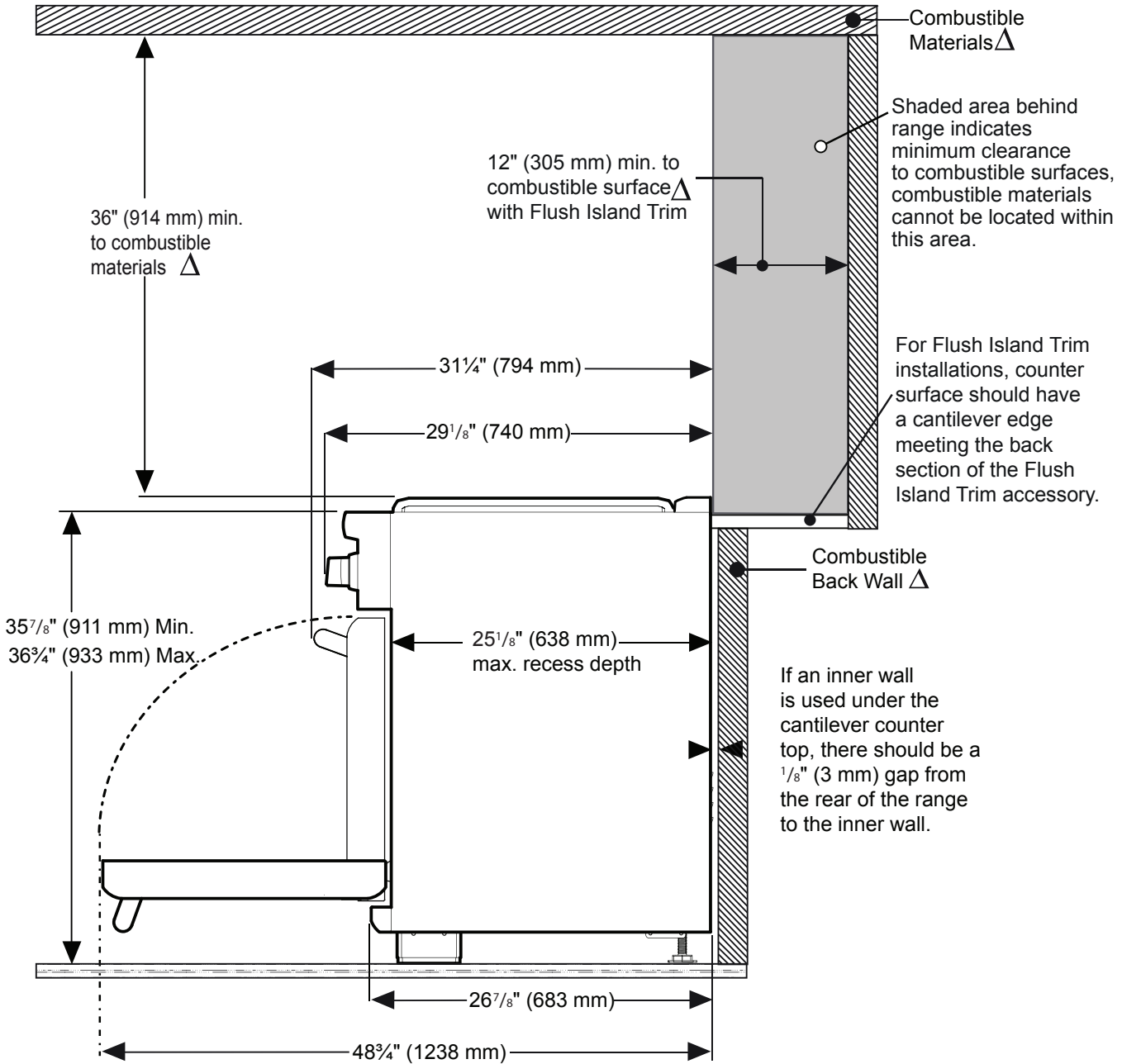

△ As defined in the "National Fuel Gas Code" (ANSI Z223.1, Current Edition). Clearances from non-combustible materials are not part of the ANSI Z21.1 scope and are not certified by CSA. Clearances of less than 12" (305 mm) must be approved by the local codes and/or by the local authority having jurisdiction.

These warranties give you specific legal rights and you may have other rights that vary from state to state. Full warranty and limited warranty from date of installation. For complete warranty details, refer to your Use & Care manual, or ask your dealer.

Specifications are for planning purposes only. Refer to installation instructions and consult your countertop supplier prior to making counter opening. Consult with a heating and ventilation engineer for your specific ventilation requirements. For the most detailed information, refer to installation instructions accompanying product or write to Thermador indicating the model number. Specifications are correct at time of printing. Thermador reserves the right to change product specifications or design without notice. Some models are certified for use in Canada. Thermador is not responsible for products that are transported from the U.S. for use in Canada.