

SRT304



FEATURES

Dual-stacked burners go from 20,000 Btu down to a mere breath of flame

Heavy-gauge stainless steel

Continuous cast-iron grates for easy movement of pots and pans

Signature red infinite control knobs

Spark ignition system re-ignites if flame goes out

Rigorously tested in our U.S. manufacturing facilities for decades of use

Exceptional 24/7 support from our Customer Care team in Madison

ACCESSORIES

2-Burner Wok Grate

Center S-Grate

Filler Trim

S-Grates

Stainless steel, brass or chrome bezels

High altitude conversion kit

Signature red, black or stainless steel control knobs

5" and 10" stainless steel risers, and 20" riser with shelf

Accessories available through an authorized dealer.

For local dealer information, visit subzero-wolf.com/locator.



KNOB OPTIONS



TOP CONFIGURATION

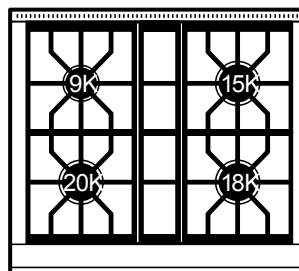

RANGETOP SPECIFICATIONS

- 1 - 9,200 Btu Burner
- 1 - 15,000 Btu Burner
- 1 - 18,000 Btu Burner
- 1 - 20,000 Btu Burner

PRODUCT SPECIFICATIONS

Model	SRT304
Dimensions	29 7/8"W x 8 1/2"H x 28 1/2"D
Weight	160 lbs
Electrical Supply	110/120 VAC, 60 Hz
Electrical Service	15 amp dedicated circuit
Gas Supply	3/4" ID line
Gas Inlet	1/2" NPT female
Receptacle	3-prong grounding-type

ELECTRICAL

GAS

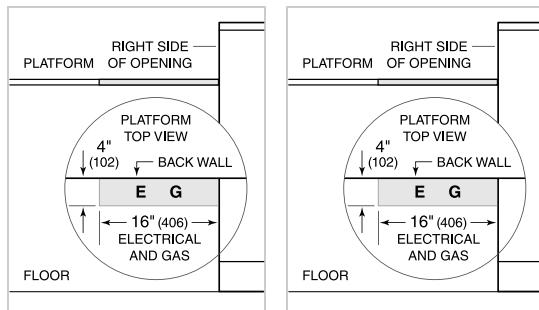

NOTE: Dimensions in parenthesis are in millimeters unless otherwise specified

DIMENSIONS

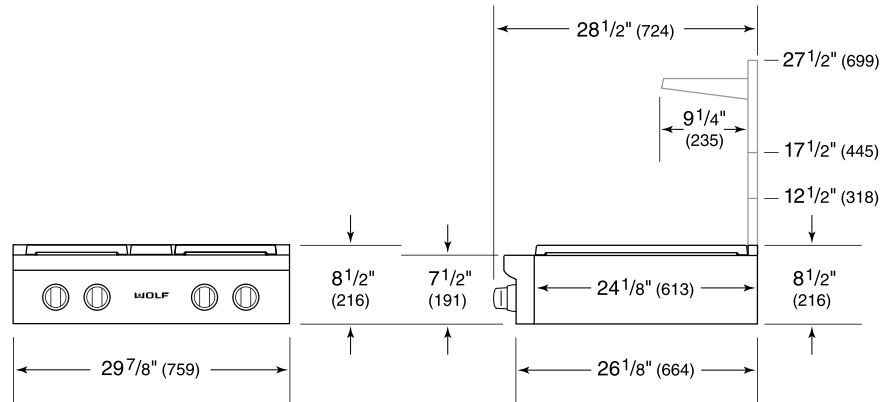

STANDARD INSTALLATION

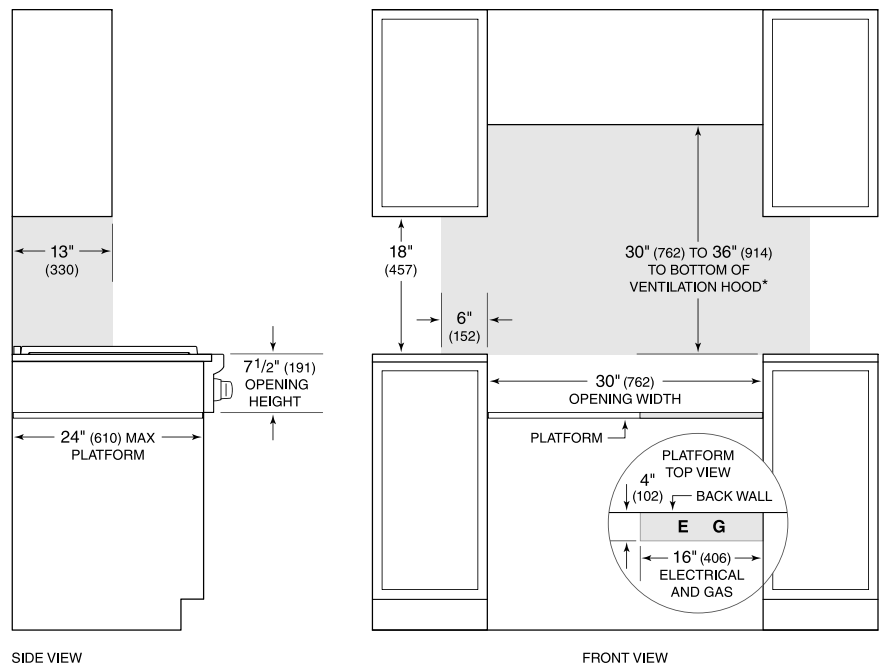

*Without ventilation hood, 36" (914) minimum clearance countertop to combustible materials.
 NOTE: Shaded area above countertop indicates minimum clearance to combustible surfaces, combustible materials cannot be located within this area.
 Electrical and gas supply located through bottom of platform.
 For island installation, 12" (305) minimum clearance back of range to combustible rear wall above countertop.