

DISHWASHER
USE AND CARE GUIDE

CLEANING, MAINTENANCE, AND MORE



Contents

- 3 Safety Precautions
- 4 Dishwasher Features
- 5 Dishwasher Operation
- 15 Care Recommendations
- 17 Troubleshooting
- 19 Cove Warranty

Customer Care

The model and serial number are printed on the enclosed product registration card. Both numbers are also listed on the product rating plate. Refer to page 4 for rating plate location. For warranty purposes, you will also need the date of installation and name of your authorized Cove dealer. Record this information below for future reference.

SERVICE INFORMATION

Model Number	_____
Serial Number	_____
Date of Installation	_____
Certified Service Name	_____
Certified Service Number	_____
Authorized Dealer	_____
Dealer Number	_____

If your product ever needs attention, be sure to use a Cove Factory Certified Service provider recommended by our Customer Care Center, or select one from our list of providers available at coveappliance.com/locator. All Factory Certified Service providers are carefully selected and thoroughly trained by us.

Important Note

To ensure this product is installed and operated as safely and efficiently as possible, take note of the following types of highlighted information throughout this guide:

IMPORTANT NOTE highlights information that is especially important.

CAUTION indicates a situation where minor injury or product damage may occur if instructions are not followed.

WARNING states a hazard that may cause serious injury or death if precautions are not followed.

IMPORTANT NOTE: Throughout this guide, dimensions in parentheses are millimeters unless otherwise specified.

IMPORTANT INSTRUCTIONS

IMPORTANT SAFETY INSTRUCTIONS

⚠ WARNING

When using your dishwasher, follow basic precautions, including the following:

- Read all instructions before using the dishwasher.
 - Use the dishwasher only for its intended function.
 - Certified residential dishwashers are not intended for licensed food establishments.
 - Use only detergents or wetting agents recommended for use in a dishwasher and keep them out of the reach of children.
 - When loading items to be washed, locate sharp items so they are not likely to damage the door seal, and load sharp knives with the handles up to reduce the risk of injuries.
 - Do not wash plastic items unless they are marked “dishwasher safe” or the equivalent. For unmarked plastic items, check the manufacturer’s recommendations.
 - Do not touch the heating element during or immediately after use.
 - Do not tamper with controls.
 - Do not operate your dishwasher unless all enclosure panels are properly in place.
 - Do not abuse, sit on, or stand on the door or dish rack of the dishwasher.
 - To avoid a tripping hazard, do not leave the dishwasher door open.
 - To reduce the risk of injury, do not allow children to play in or on a dishwasher.
- Under certain conditions, hydrogen gas may be produced in a hot water system that has not been used for two or more weeks. **HYDROGEN GAS IS EXPLOSIVE.** If the hot water system has not been used for two or more weeks, before using the dishwasher, turn on all hot water faucets and let the water flow from each for several minutes. This releases any accumulated hydrogen gas. As the gas is flammable, do not smoke or use an open flame during this time.
 - Only wash cycles with the Sani Rinse option selected have been designed to meet the NSF/ANSI 184 performance standard for soil removal and sanitization efficacy. There is no intention, either directly or indirectly, that all cycles on a certified machine have passed the sanitization performance test.
 - Remove the door to the washing compartment when removing an old dishwasher from service or discarding it.
 - Any opening into the adjacent cabinet must meet the following: the longest dimension of the opening shall not be more than 1¹/₂" (38).

⚠ WARNING

PROPOSITION 65 FOR CALIFORNIA RESIDENTS
Cancer and Reproductive Harm—
www.P65Warnings.ca.gov

⚠ WARNING

 **DANGEROUS VOLTAGE.**

SAVE THESE INSTRUCTIONS

Dishwasher Features

FEATURES

1	Product Rating Plate
2	Hidden Control Panel
3	Control Panel Display
4	Removable Upper Rack
5	Height-Adjustable Middle Rack
6	Lower Rack
7	Fold-Down Tine Adjustment
8	Fold-Down Shelf
9	Stemware Cradle
10	Middle Spray Arm
11	Detergent/Rinse Aid Dispenser
12	LED Lit Interior
13	Status Light (right side, below door)

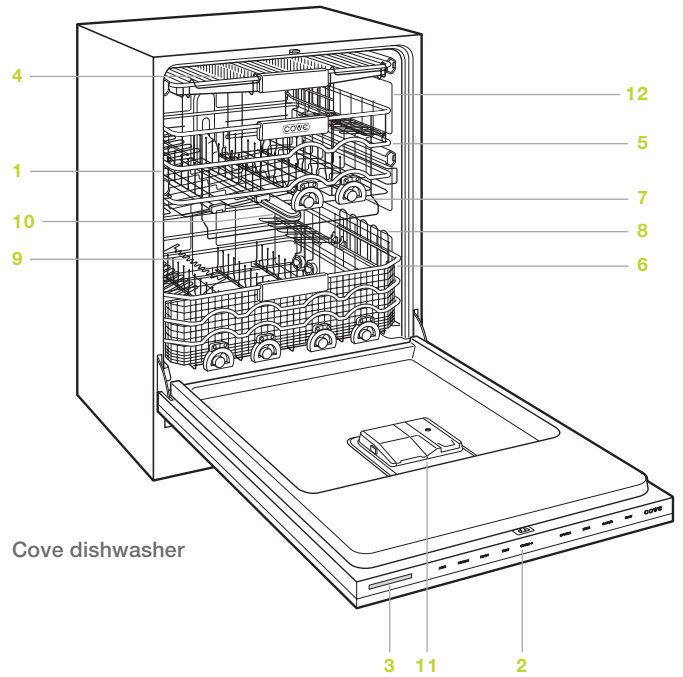

Getting Started

We know you are eager to start using your Cove dishwasher, but before you do, please take some time to read this use and care guide. It will be to your benefit to familiarize yourself with the safety practices, features, operation, and care recommendations of your Cove dishwasher.

NOTE: Every unit is tested prior to shipment and may contain residual water.

Prior to Use

For softener models only, use the test strip provided to determine the water hardness. Refer to User Setup on page 8 to adjust the hardness setting.

Fill the salt compartment with water prior to adding salt for the first time. Refer to Water Softener on page 14 for more information.

Plate Arrangement

The illustrations below show typical arrangement for the upper, middle, and lower racks. The adjustable middle rack was AHAM tested in the top position.

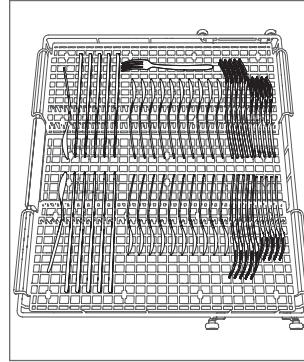

Upper rack

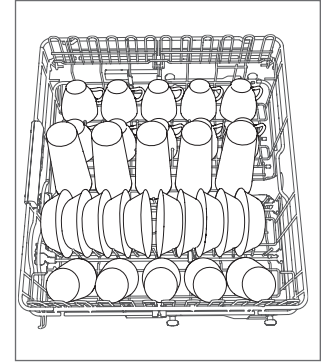

Middle rack

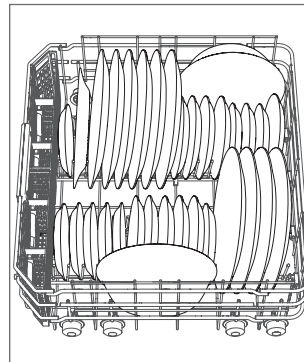

Lower rack

Dishwasher Operation

CONTROL PANEL

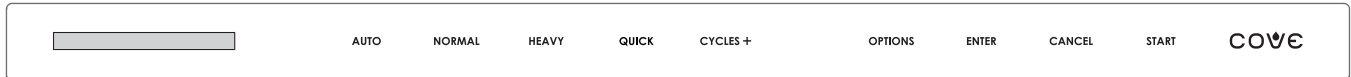

Control panel

WASH CYCLES

Setting a wash cycle:

- 1 Touch the desired wash cycle or touch Cycles+ multiple times to scroll to the desired wash cycle.
- 2 Touch Start and close the door within 4 seconds.

NOTE: To incorporate a cycle option to the wash cycle, touch Options before touching Start. Refer to Cycle Options. To change the cycle after touching Start, touch Cancel.

CYCLE OPTIONS

OPTION	DESCRIPTION
Delay Start	Delays the start of the wash cycle by 1–12 hours in 1-hour increments.
High Temp Wash	Increases the main wash water temperature and extends the cycle time by 10 minutes.
Sani Rinse*	Increases the rinse water temperature and extends the rinse time.
Extended Dry	Extends the dry time by 30 minutes.
Extra Dry	Increases the rinse water temperature and extends the dry time by 30 minutes.
Top Racks Only	Directs wash functions to upper and middle racks only.

*Sanitizes per NSF/ANSI standard 184 for residential dishwashers.

Setting cycle options:

- 1 Select the desired wash cycle.
- 2 Touch Options.
- 3 Touch Options multiple times to scroll through cycle options.
- 4 Touch Enter to select the desired option and continue to touch Enter until the desired setting appears on the display.
- 5 Touch Options again to select additional options.
- 6 Touch Start and close the door within 4 seconds.

To interrupt a cycle:

- 1 Open the door.
- 2 To restart the cycle, touch Start and close the door within 4 seconds.

To cancel a cycle:

- 1 Open the door.
- 2 Touch Cancel and follow the instructions on the display.

DISHWASHER OPERATION

Dishwasher Operation

WASH CYCLES

CYCLE	CYCLE TIME*	DRY TIME	WATER USAGE	DETERGENT**	OPTIONS
AUTO	2:05 to 3:55	:40	3.7 to 7.2 gal	2 tbsp	Delay Start, High Temp Wash, Sani Rinse, Extended Dry, Extra Dry, Top Racks Only
NORMAL	2:40	:35 to :40	2.7 to 6.1 gal	2 tbsp	Delay Start, High Temp Wash, Sani Rinse, Extended Dry, Extra Dry, Top Racks Only
HEAVY	3:25	:40	6.7 gal	2 tbsp	Delay Start, High Temp Wash, Sani Rinse, Extended Dry, Extra Dry
QUICK***	:58	:10	3.3 gal	1/2 tbsp	Extra Dry, Top Racks Only

CYCLES+	CYCLE TIME*	DRY TIME	WATER USAGE	DETERGENT**	OPTIONS
POTS & PANS	3:55	:40	7.6 gal	2 tbsp	Delay Start, High Temp Wash, Sani Rinse, Extended Dry, Extra Dry
SOAK & SCRUB	5:35	:40	7.6 gal	2 tbsp	Delay Start, High Temp Wash, Sani Rinse, Extended Dry, Extra Dry
LIGHT***	1:53	:15	2.8 gal	2 tbsp	Delay Start, High Temp Wash, Sani Rinse, Extended Dry, Extra Dry, Top Racks Only
CHINA/CRYSTAL	1:58	:40	2.8 gal	1/2 tbsp	Delay Start, Extended Dry, Top Racks Only
RINSE/HOLD	:15	:00	2.2 gal	0 tbsp	
PLASTICS	2:33	:45	2.8 gal	1 tbsp	Delay Start, High Temp Wash, Sani Rinse, Extended Dry, Extra Dry
ENERGY	2:08	:40	2.6 gal	2 tbsp	Delay Start, Extended Dry
EXTRA QUIET	2:51	:40	4.3 gal	2 tbsp	Delay Start, Extended Dry, Extra Dry, Top Racks Only

*Includes dry time. **Powdered detergent. ***Shortened cycle time impacts drying performance.

Dishwasher Operation

USER SETUP

The user setup feature allows the user to select preferences as listed in the chart below.

USER OPTIONS

Language	Select language.
Water Hardness	Adjust water hardness setting.
Connect?	Turn connect on or off.*
Tone Level	Adjust tone level.
Notification	Turn end-of-cycle chime on or off.
Scroll Rate	Adjust display scroll rate.
Display Contrast	Adjust display contrast.
Display Brightness	Adjust display brightness.
Floor Light	Adjust status light brightness.
Rinse Aid Dosing	Adjust amount of rinse aid dispensed.
Showroom Mode	For showroom use only.
Reset All	Restore factory settings.

**To connect to the Sub-Zero Group Owners App, connect must be turned on.*

Setting user options:

- 1 Touch Cancel twice.
- 2 Touch and hold Options for approximately 3 seconds until “User Set Up” appears on the display.
- 3 Touch Options multiple times to scroll to the desired option.
- 4 Touch Enter to scroll or to select the desired setting.
- 5 Touch Cancel to exit user setup.

WATER HARDNESS

For water softener models only, use the test strip provided and the chart below to determine the appropriate water hardness setting. Refer to the chart below to determine the water hardness setting.

SETTING	HARDNESS
0 (Default)	0–4 gpg
1	5–6 gpg
2	7–8 gpg
3	9–11 gpg
4	12–13 gpg
5	14–15 gpg
6	16–17 gpg
7	18–19 gpg
8	20–22 gpg
9	23–24 gpg
10	25+ gpg

Child Lock

The child lock feature prevents unwanted control panel operation. The lock feature will remain on even after a power outage.

To turn the child lock feature on or off:

- 1 To turn on, touch and hold Heavy for approximately 10 seconds until “Child Lock: On” appears on the display. “Locked” will appear on the display until the child lock is turned off.
- 2 To turn off, touch and hold Heavy for approximately 10 seconds until “Child Lock: Off” appears on the display.

IMPORTANT NOTE: Child lock and Sabbath feature cannot be turned on at the same time.

Sabbath

This appliance is certified by Star-K to meet strict religious regulations in conjunction with specific instructions found on www.star-k.org.

The Sabbath feature will remain on even after a power outage.

To turn the Sabbath feature on or off:

- 1 To turn on, touch and hold Quick for approximately 10 seconds until “Sabbath” appears on the display. “Sabbath” will appear on the display until the Sabbath feature is turned off.
- 2 To turn off, touch and hold Quick for approximately 10 seconds until “Sabbath Off” appears on the display.

IMPORTANT NOTE: Child lock and Sabbath feature cannot be turned on at the same time.

Lights

STATUS LIGHT

The status light will illuminate to indicate the status of the cycle.

LIGHT	CYCLE STATUS
Blue	A delayed start has been selected. Touch Start each time the door is opened prior to the start time.
Red	The cycle has started.
Green	The cycle is complete.
No Light	The door was not closed within 4 seconds after touching Start, the cycle has been complete for more than two hours, or the door has been opened.

INTERIOR LIGHT

The interior lights will turn on when the door is open. The lights remain on for 10 minutes, dim after 10 minutes, and turn off after 15 minutes. Any door movement turns the lights on.

Dishwasher Racks

RACK REMOVAL

All of the racks can be removed. If desired, the dishwasher can be operated with any of the racks removed.

To remove the upper and middle racks:

IMPORTANT NOTE: If the middle rack is removed, the spray nozzle must be installed before starting a cycle. Refer to the illustration below.

- 1 Pull the rack out to full extension.
- 2 Pull out on the tab on the side of the rack clips and remove the clips from the end of each rack glide. Refer to the illustration below.
- 3 Pull the rack forward to remove.

To remove the lower rack:

- 1 Pull the rack out to full extension.
- 2 Lift up and out.

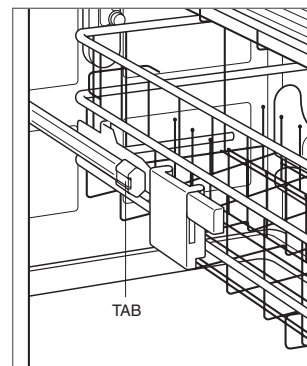

Rack removal

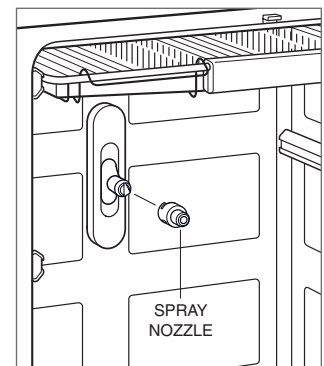

Spray nozzle installation

Dishwasher Racks

HEIGHT-ADJUSTABLE RACK

To move the rack down:

- 1 Pull the empty rack out to full extension.
- 2 Lift the green adjustment levers on each side up and allow the rack to move downward to the desired location. The adjustment levers are only used to move the rack down. Refer to the illustration below.

To move the rack up:

- 1 Pull the rack out to full extension.
- 2 Lift up on the rack above the adjustment levers.

FOLD-DOWN TINES

Some of the tines can be adjusted to accommodate a variety of dinnerware.

To adjust the fold-down tines:

- 1 Pull the rack out to full extension.
- 2 Push and turn the green adjustment tabs to fold down the desired tines. Refer to the illustration below.

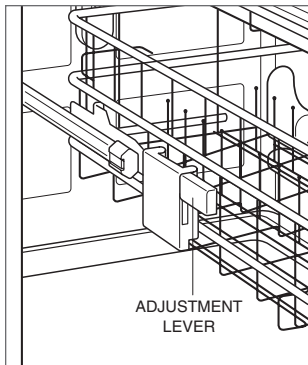

Height adjustment

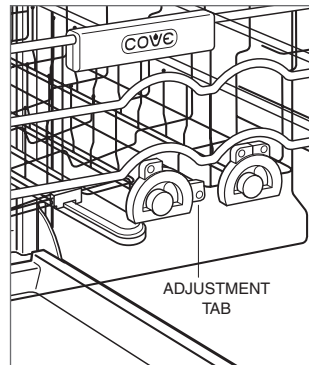

Tine adjustment

FOLD-DOWN SHELVES

The lower and middle racks have fold-down shelves that can be adjusted to accommodate smaller items and support stemware.

To adjust the fold-down shelves:

- 1 Rotate the shelf down. Refer to the illustration below.

STEMWARE CRADLE

The lower rack has a stemware cradle that can be adjusted to accommodate stemware.

To adjust the stemware cradle:

- 1 Rotate the cradle downward. Refer to the illustration below.

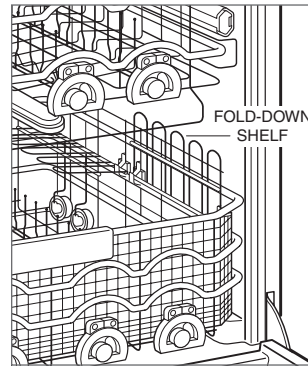

Fold-down shelf

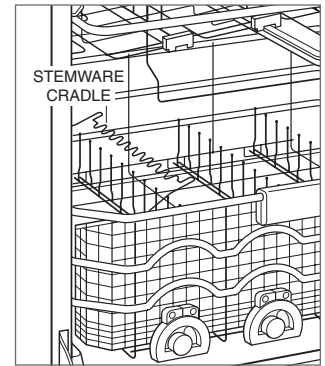

Stemware cradle

Dishwasher Racks

UTENSIL BASKET

The utensil basket is located at the front of the lower rack and can be removed.

To remove the utensil basket:

- 1 Pull the lower rack out to full extension.
- 2 Lift the basket up and out.

▲ WARNING

Knives and other utensils with sharp points must be loaded in the basket with their points down or placed in a horizontal position.

SPRAY ARM DOCKING

A spray arm is integrated into the middle rack. The spray arm conduit is designed to be pushed into a docking station on the rear wall to connect to the water supply. Refer to the illustration below.

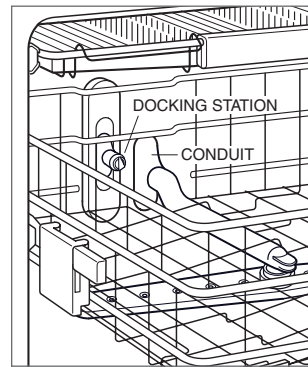

Spray arm docking

Dispenser

The dispenser located on the interior of the door has one compartment for detergent and another for rinse aid. Refer to the illustrations below. Cove recommends the use of Finish® detergent.

NOTE: Finish® is a trademark of Reckitt Benckiser N.V.

To add dishwasher detergent:

- 1 Add detergent to the compartment on the left.
- 2 Slide the cover closed.

To open the door once closed, touch the button on the side of the dispenser.

To add rinse aid:

- 1 Lift the tab of the cover on the right.
- 2 Add rinse aid. The rinse aid compartment is full when the indicator appears the color of the rinse aid.
- 3 Wipe away any rinse aid that may have spilled.

When rinse aid is low, “Add Rinse Aid. Enter once added, Cancel to ignore.” appears on the display.

⚠ CAUTION

Do not add anything other than dishwasher detergent to the detergent compartment and rinse aid to the rinse aid compartment.

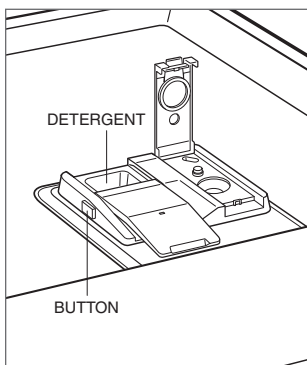

Detergent dispenser

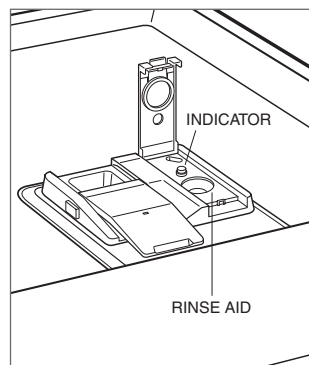

Rinse aid dispenser

Water Softener

For water softener models only, a salt compartment is located at the bottom of the interior. Refer to the illustration below.

Prior to filling the salt compartment for the first time, fill the compartment with water. Water does not have to be added with subsequent refills.

When softener salt is low, “Add Salt. Enter once added, Cancel to ignore.” appears on the display.

To add softener salt:

- 1 Pull the lower rack forward and if necessary, turn the lower spray arm away from the compartment cover.
- 2 Turn the cover counterclockwise to remove. It is normal for the reservoir to contain water.
- 3 Fill the compartment completely with dishwasher softener salt.
- 4 Once full, clean any excess salt from the threads of the salt compartment, then turn the cover clockwise to secure.
- 5 Run a Quick cycle.

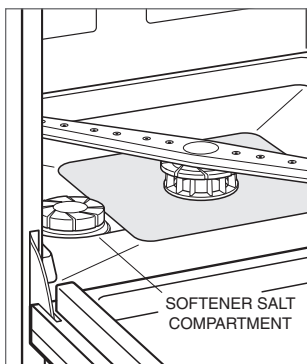

Softener salt compartment

⚠ CAUTION

Do not add anything other than dishwasher salt to the salt compartment.

The water softener must regenerate periodically to maintain water quality. When necessary, the regeneration process starts automatically before the next wash cycle (excluding Quick and Rinse/Hold) and lasts approximately 20 minutes. The wash cycle begins after the regeneration process is complete. “Water softener active. Press Start” appears on the display during the regeneration process. To continue, touch Start and close the door.

Cleaning

SPRAY ARMS

The upper and lower spray arms are removable for cleaning. The middle spray arm is not removable.

To remove the upper spray arm:

- 1 To access the upper spray arm, remove the upper rack.
- 2 Turn the spray arm assembly counterclockwise to remove.

To remove the lower spray arm:

- 1 To access the lower spray arm, remove the lower rack.
- 2 Turn lower spray arm assembly counterclockwise $\frac{1}{8}$ turn, then lift up to remove. Refer to the illustration below.

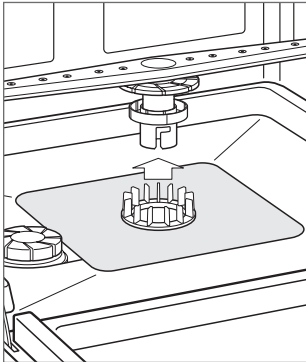

Lower spray arm removal

FILTER

The filter should be cleaned often. Heavy use may require more frequent cleaning. "Clean Filter." appears on the display after 30 cycles. This is a reminder and is not based on the soil level of the filter. To reset, touch Cancel.

To remove the filter:

- 1 Remove the lower rack and lower spray arm.
- 2 Turn the filter counterclockwise, then lift up to remove. Refer to the illustration below.

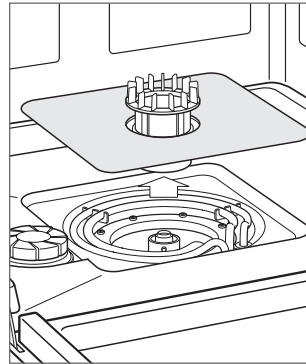

Filter removal

Care Recommendations

CLEANING

Stainless steel	Use a nonabrasive stainless steel cleaner and apply with a soft lint-free cloth. To bring out the natural luster, lightly wipe surface with a water-dampened microfiber cloth followed by a dry polishing chamois. Always follow the grain of stainless steel.
Control panel	Wipe with a damp cloth.
Dishwasher racks	Refer to page 10 for removal. Wipe with a damp cloth.
Interior	Wipe interior, door edge, and rubber seal with a damp cloth. If necessary, spray household cleaner on the cloth. Do not spray directly on the door. To remove calcium or lime build-up, empty the dishwasher. Fill the detergent compartment with 2 tbsp of citric acid crystals, then close the cover. Run a Normal wash cycle. Add 1 tbsp of dishwasher detergent to the compartment, then run a Normal wash cycle again.
Spray arms	Refer to page 15 for removal. Use a paper clip or similar to remove debris from holes.
Filter	Refer to page 15 for removal. Clean with soap and water. For hard-to-remove soils or calcium deposits, use a soft brush. Do not use a wire brush or scouring pad.
Gasket	Wipe with a damp cloth. Use warm soapy water and a toothbrush. If mold or mildew are present, spray with 3% hydrogen peroxide.

Troubleshooting

OPERATION

Dishwasher does not operate.

- Verify power is on.
- Verify electrical power to dishwasher and home circuit breaker is on.
- Verify the child lock, Sabbath feature, and showroom mode are not turned on.

Dishes are not clean after wash cycle.

- Verify hot water supply.
- Verify spray arms turn freely by turning by hand.
- Verify dishes are not placed too close together and cups and bowls are face-down and are not nested.
- Contact Cove Customer Care at 800-222-7820 for recommendations.

“Check manual, Code #050140” appears on the display.

- Verify the drain is clear and free of debris.
- Verify drain line is not kinked.

“Check manual, Code #560186 or #560187” appears on the display.

- Verify water supply is in the on position.
- Verify water supply line is not kinked.

“Overfill Detected” appears on the display.

- Touch Cancel to reset.
- If it reappears, contact Cove Factory Certified Service.

“Check manual, Code #700197” appears on the display.

- Verify an overturned bowl or additional liquid was not added to the load.
- Remove and clean the filters.
- Cancel and restart the cycle.

“Call Service, Code #600148”, #600149, or #600151” appears on the display.

- Contact Cove Factory Certified Service.

Service

- Maintain the quality built into your product by contacting Cove Factory Certified Service. For the name of the nearest Cove Factory Certified Service, check the contact and support section of our website, coveappliance.com, or call Cove Customer Care at 800-222-7820.
- When contacting service, you will need the model and serial number of your product. Both numbers are listed on the product rating plate. Refer to page 4 for rating plate location.
- For warranty purposes, you will also need the date of installation and name of your authorized Cove dealer. This information should be recorded on page 2 of this guide.

Cove Appliance Residential Limited Warranty

FOR RESIDENTIAL USE

FULL FIVE YEAR WARRANTY*

For five years from the date of original installation, this Cove Appliance product warranty covers all parts and labor to repair or replace, under normal residential use, any part of the product that proves to be defective in materials or workmanship. All service provided by Cove Appliance under the above warranty must be performed by Cove factory certified service, unless otherwise specified by Cove Appliance, Inc. Service will be provided during normal business hours.

LIMITED LIFETIME WARRANTY

For the life of the product, Cove Appliance will repair or replace the following parts that prove to be defective in materials or workmanship: stainless steel tub and door liner (excludes surface corrosion, scratches, discoloration, weather and atmospheric related staining and minor surface rust and oxidation). If the owner uses Cove factory certified service, the service provider will repair or replace these parts with the owner paying for all other costs, including labor. If the owner uses non-certified service, the owner must contact Cove Appliance, Inc. (using the information below) to receive repaired or replacement parts. Cove Appliance will not reimburse the owner for parts purchased from non-certified service or other sources.

TERMS APPLICABLE TO EACH WARRANTY

The warranty applies only to products installed for normal residential use. The warranty applies only to products installed in any one of the fifty states of the United States, the District of Columbia or the ten provinces of Canada. This warranty does not cover any parts or labor to correct any defect caused by negligence, accident or improper use, maintenance, installation, service or repair.

THE REMEDIES DESCRIBED ABOVE FOR EACH WARRANTY ARE THE ONLY ONES THAT COVE APPLIANCE, INC. WILL PROVIDE, EITHER UNDER THIS WARRANTY OR UNDER ANY WARRANTY ARISING BY OPERATION OF LAW. COVE APPLIANCE, INC. WILL NOT BE RESPONSIBLE FOR ANY CONSEQUENTIAL OR INCIDENTAL DAMAGES ARISING FROM THE BREACH OF THIS WARRANTY OR ANY OTHER WARRANTY, WHETHER EXPRESS, IMPLIED OR STATUTORY.

Some states do not allow the exclusion or limitation of incidental or consequential damages, so the above limitation or exclusion may not apply to you. This warranty gives you specific legal rights and you may also have other legal rights that vary from state to state.

To receive parts and/or service and the name of Cove factory certified service nearest you, contact Cove Appliance, Inc., P.O. Box 44848, Madison, WI 53744; check the contact & support section of our website, coveappliance.com, email us at customerservice@subzero.com or call 800-222-7820.

*Stainless steel (doors, panels, handles, product frames and interior surfaces) are covered by a limited 60-day parts and labor warranty for cosmetic defects.





COVE APPLIANCE, INC. P.O. BOX 44848 MADISON, WI 53744 COVEAPPLIANCE.COM 800.222.7820

9013807 REV-B

4/2018

