

Digital 4K Video Camera Recorder  
FDR-AX700



Use this Help Guide when you have any questions on how to use your product.  
This Help Guide is also available as a PDF, which can be downloaded [here](#).

## Before use

### Parts and controls

- Parts and controls (left front side/front) >
- Parts and controls (right front side/top) >
- Parts and controls (left back side/left back/bottom) >
- Parts and controls (right back side/back) >
- Parts and controls (wireless remote commander) >
- Changing the battery of the wireless remote commander >

### Screen indicators

### Selecting the items on the LCD monitor

### Recording formats available with the camcorder and their features

### Getting started

## Supplied items

---

### Power source preparations

---

- [Attaching the battery pack](#) >
- [Charging the battery pack using the AC Adaptor](#) >
- [Turning the power on](#) >
- [Using the camcorder supplying power from a wall outlet \(wall socket\)](#) >

### Adjusting the LCD monitor and viewfinder

---

- [Adjusting the viewfinder](#) >
- [Adjusting the LCD monitor](#) >

### Initial setting

---

#### Preparing a memory card

---

- [Inserting a memory card](#) >
- [Selecting the memory card slot to be used for recording](#) >
- [Types of memory card you can use with your camcorder](#) >

## Recording

---

### Recording movies

---

- [Recording movies](#) >
- [Continuing recording on the memory cards one after another \(Relay recording\)](#) >
- [Recording movies on both the memory card A and B \(Simultaneous recording\)](#) >

### Shooting photos

---

#### Using the zoom

---

- [Adjusting the zoom with the zoom lever](#) >
- [Adjusting the zoom with the manual lens ring](#) >

#### Adjusting the focus

---

- [Adjusting the focus manually](#) >
- [Adjusting the focus automatically](#) >
- [FOCUS AREA](#) >
- [Phase detection AF](#) >
- [AF DRIVE SPEED](#) >
- [AF SUBJ. TRACK SET](#) >

- Adjusting focus by tracking the desired subject (LOCK-ON AF) >
- Focusing by magnifying an image (FOCUS MAGNIFIER) >
- Focusing by touching the LCD monitor (SPOT FOCUS) >
- Focusing on a detected face (FACE DETECTION) >

### Adjusting the brightness

- Adjusting the iris >
- Adjusting the gain >
- Adjusting the ISO sensitivity >
- Adjusting the shutter speed >
- Adjusting the light quantity (ND filter) >

### Adjusting the color tone

- Adjusting the color to the natural tone (WHITE BALANCE) >
- Storing the adjusted white balance value in memory A or B >

### Audio setup

- Recording audio with the internal microphone >
- Recording audio with a Multi interface shoe compatible microphone (sold separately) >
- Recording audio with an external microphone (sold separately) >

### Useful functions

- Shooting in dark conditions (NIGHTSHOT) >
- Shooting with the picture quality that is set in advance (PICTURE PROFILE) >
- Changing the picture profile >
- Copying the picture profile setting to another picture profile number >
- Resetting the picture profile settings >
- Recording with Slow & Quick Motion >
- Recording with Super Slow Motion >
- Performing shooting adjustment with Direct Menu >
- Proxy recording >
- Reviewing the most recently recorded scene (LAST SCENE REVIEW) >

### Assigning the functions to the ASSIGN buttons

### Playback

## Playing images on the camcorder

- Playing back movies >
- Playing back photos >

## Changing/checking the settings of the camcorder

- Changing the screen display >
- Displaying recording data (DATA CODE) >
- Checking the settings in the camcorder (STATUS CHECK) >

## Viewing images on the TV

- On the HDMI cable >
- Viewing images on a 4K TV >
- Viewing images on a high definition TV >
- Viewing images on a non-high-definition TV >

## Editing

### Notes on editing

### Protecting movies and photos (PROTECT)

### Deleting selected movies/photos

### Dividing a movie

## Saving images

### Saving movies

### Using the PlayMemories Home software

- Import and utilize images on your computer (PlayMemories Home) >
- Checking the computer system >
- Installing the PlayMemories Home software in your computer >
- Disconnecting the camcorder from the computer >
- Creating a Blu-ray disc >

### Creating a disc with a recorder

## Using the Wi-Fi function

### About the PlayMemories Mobile software

### Connecting a smartphone

- Connecting to an NFC-enabled smartphone or tablet >

- [Connecting to a smartphone or tablet using the QR Code](#) >
- [Connecting to your Android smartphone or tablet \(by entering an SSID and password\)](#) >
- [Connecting to your iPhone or iPad \(by entering an SSID and password\)](#) >

### Controlling via a smartphone

- [Using your smartphone or tablet as a wireless remote commander](#) >
- [Using your smartphone or tablet as a wireless remote commander using the NFC function \(NFC one-touch remote\)](#) >

### List of menu items

#### Setting up menu items

#### How to use the keyboard

### CAMERA SET

- [ISO/GAIN SEL](#) >
- [AUTO ISO LIMIT](#) >
- [AGC LIMIT](#) >
- [WB PRESET](#) >
- [WB OUTDOOR LEVEL](#) >
- [WB TEMP SET](#) >
- [WB SET](#) >
- [AE SHIFT](#) >
- [D. EXTENDER](#) >
- [ZOOM SET](#) >
- [STEADYSHOT \(Movie\)](#) >
- [STEADYSHOT \(Photo\)](#) >
- [FOCUS AREA](#) >
- [AF DRIVE SPEED](#) >
- [AF SUBJ. TRACK SET](#) >
- [LOCK-ON AF](#) >
- [FACE DETECTION](#) >
- [SLOW & QUICK \(S&Q MOTION\)](#) >
- [SLOW & QUICK \(SUPER SLOW MOTION\)](#) >
- [AUTO MODE SET](#) >

- SCENE SELECTION SET >

---

- SPOT METER/FOCUS >

---

- SPOT METER >

---

- SPOT FOCUS >

---

- LOW LUX >

---

- AUTO BACK LIGHT >

---

- NIGHTSHOT >

---

- NIGHTSHOT LIGHT >

---

- COLOR BAR >

---

- PICTURE PROFILE >

#### REC/OUT SET

- SHOOTING MODE >

---

- REC SET >

---

- IMAGE SIZE >

---

- FILE NUMBER >

---

- VIDEO OUT >

#### AUDIO SET

- VOLUME >

---

- AVCHD AUDIO FORMAT >

---

- AUDIO REC LEVEL >

---

- INT MIC WIND >

---

- MIC SELECT >

---

- AUDIO OUTPUT TIMING >

#### DISPLAY SET

- HISTOGRAM >

---

- ZEBRA >

---

- PEAKING >

---

- PHASE AF FRAMES >

---

- PHASE DETECT. AF AREA >

---

- MARKER >

- FOCUS MAG RATIO >

---

- CAMERA DATA DISPLAY >

---

- AUDIO LEVEL DISPLAY >

---

- ZOOM DISPLAY >

---

- FOCUS DISPLAY >

---

- SHUTTER DISPLAY >

---

- DATA CODE >

---

- GAMMA DISP ASSIST >

---

- LCD BRIGHT >

---

- VF COLOR TEMP. >

---

- DISPLAY OUTPUT >

#### TC/UB SET

- TC/UB DISPLAY >

---

- TC PRESET >

---

- UB PRESET >

---

- TC FORMAT >

---

- TC RUN >

---

- TC MAKE >

---

- UB TIME REC >

#### NETWORK SET

- CTRL W/SMARTPHONE >

---

- Wi-Fi SET >

---

- AIRPLANE MODE >

---

- NETWORK RESET >

#### OTHERS

- STATUS CHECK >

---

- CAMERA PROFILE >

---

- S&Q BUTTON SETTING >

---

- ASSIGN BUTTON >

---

- CLOCK SET >

AREA SET	>
DST SET (SUMMERTIME)	>
LANGUAGE	>
DATE REC	>
BEEP	>
REC LAMP	>
REMOTE CONTROL	>
60i/50i SEL	>
MEDIA FORMAT	>
REPAIR IMAGE DB FILE	>
USB CONNECT	>
USB LUN SET	>
OPERATION TIME	>
VERSION DISPLAY	>
CALIBRATION	>
INITIALIZE	>
EDIT	
PROTECT	>
DELETE	>
DIVIDE	>

## Charging time/recording time of movies/number of recordable photos

### Charging time

#### Expected recording and playback times for individual batteries

Expected recording time with each battery pack	>
Expected playback time with each battery pack	>

#### Expected movie recording time and number of recordable photos for memory cards

Notes on recording movies	>
Expected recording time of movie	>
Expected number of recordable photos	>

### Bit-rate and recording pixels



[Recording pixels and aspect ratio of Proxy recording](#)

---

[Recording pixels and aspect ratio of photos](#)

---

## [Precautions/This product](#)

### [Precautions](#)

- [About XAVC S format](#) >

---

- [About the AVCHD format](#) >

---

- [About the memory card](#) >

---

- [About the InfoLITHIUM battery pack](#) >

### [Handling of this product](#)

- [On use and care](#) >

---

- [On connecting to a computer or accessory etc.](#) >

---

- [Notes on optional accessories](#) >

---

- [On moisture condensation](#) >

---

- [Notes on disposal/transfer the ownership of the camcorder](#) >

---

- [Notes on disposal/transfer of the memory card](#) >

### [Maintenance](#)

- [On handling the LCD monitor](#) >

---

- [Care of the OLED panel display](#) >

---

- [To clean the casing](#) >

---

- [About care and storage of the lens](#) >

### [Using the camcorder abroad](#)

[On trademarks](#)

---

[Notes on the License](#)

---

[Zoom magnifications](#)

---

[Using the camcorder after a long time](#)

---

## [Troubleshooting](#)

[If you have problems](#)

---

[Self-diagnosis display](#)

---

[Warning Indicators](#)



Parts and controls (left front side/front)

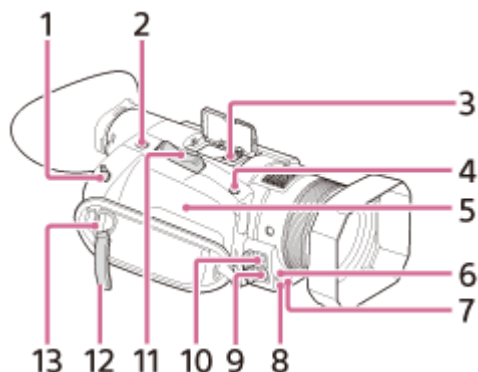

1. REMOTE jack

For connecting the camcorder and a peripheral. You can control the camcorder, such as recording movies, with that device.

2. ASSIGN4 button / FOCUS MAGNIFIER button / PHOTO button (Photo mode only)

3. Multi interface shoe



- For details on compatible accessories of the Multi interface shoe, visit the Sony web site in your area, or consult your Sony dealer or local authorized Sony service facility. Operations with other manufacture’s accessories are not guaranteed.
- If you use a shoe adaptor (sold separately), you can also use accessories compatible with an Active Interface Shoe.
- To prevent failure, do not use a commercially available flash with high-voltage synchro terminals or with reverse polarity.

4. ASSIGN5 button / IRIS PUSH AUTO button

5.  (N mark)

- Touch an NFC-enabled smartphone to the mark to establish a connection with the camcorder.
- Near Field Communication (NFC) is an international standard for short-range wireless communication technology.

6. Remote sensor

7. Recording lamp

Flashes when the remaining battery level is low or free space of the memory card is low.

8. NIGHTSHOT light emitter

9. Multi/Micro USB Terminal

VIDEO OUT jack

10. MIC jack (PLUG IN POWER)

11. Power zoom lever

12. Cable clamber

- Dedicated to fix the HDMI cable only. Do not attach other objects such as the shoulder strap to here.

13. Hook for shoulder strap

## Parts and controls (right front side/top)

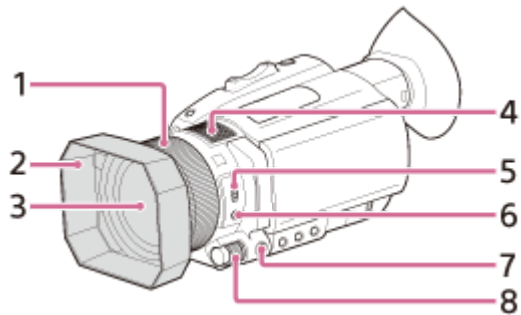

1. Manual lens ring
2. Lens hood
3. Lens (ZEISS lens)
4. Internal microphone
5. ZOOM/FOCUS switch
6. AF/MF button
7. MENU button
8. Manual dial

### Attaching the lens hood

Align the marks on the lens hood to those on the camcorder, attach the lens hood to the camcorder (ⓐ), and then turn the lens hood in the direction of arrow ⓑ until it is locked.

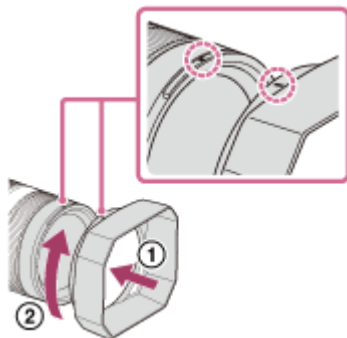

#### Hint

- If you attach or remove a 62 mm (2 1/2 in.) PL filter or MC protector, remove the lens hood.

Digital 4K Video Camera Recorder  
FDR-AX700

## Parts and controls (left back side/left back/bottom)

---

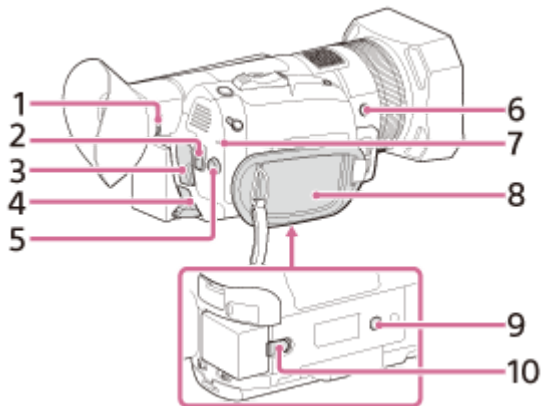

1. Lens adjustment dial
2. START/STOP button
3. HDMI OUT Terminal
4. DC IN jack
5. ▲/▼/◀/▶/SET button
6. ASSIGN6 button
7. POWER/CHG (charge) lamp
8. Grip belt
9. Tripod receptacles (1/4 inch)  
For 1/4-20UNC screws.  
For attaching a tripod with a screw shorter than 5.5 mm (sold separately). Some tripods may not be designed to attach in the proper direction.
10. BATT (battery) release lever

Parts and controls (right back side/back)

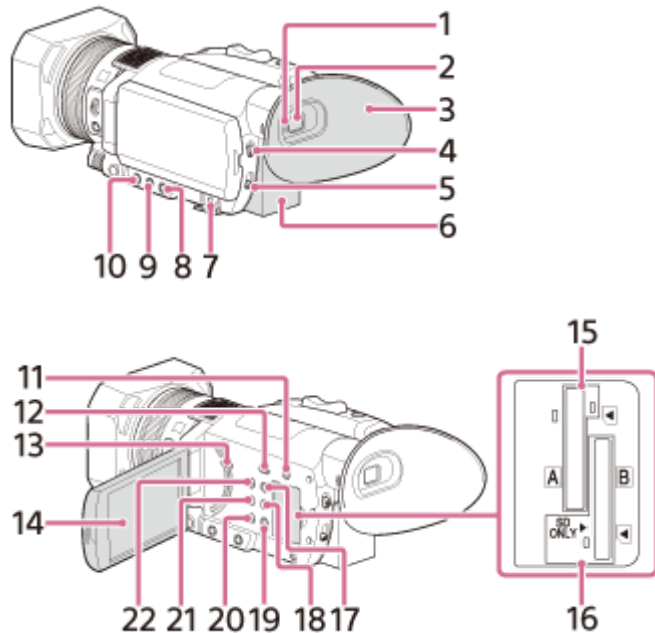

1. Eye sensor
2. Viewfinder
3. Large eyecup
4. AUTO/MANUAL switch
5. ND FILTER switch
6. Battery pack
7. (Headphones) jack
8. SHUTTER SPEED button
9. ISO/GAIN button
10. IRIS button
11. SLOT SELECT button
12. THUMBNAIL (playback) button
13. Speaker
14. LCD monitor/touch panel  
If you rotate the LCD monitor 180 degrees, you can close the LCD monitor with the screen facing out. This is convenient during playback operations.
15. Memory card slot A/Memory card access lamp
16. Memory card slot B/Memory card access lamp
17. DISPLAY button
18. ASSIGN3 button/PICTURE PROFILE button
19. ASSIGN2 button/STATUS CHECK button
20. ASSIGN1 button/S&Q button
21. WHITE BALANCE button
22. (On/Standby) button

## Parts and controls (wireless remote commander)

Remove the insulation sheet before using the wireless remote commander.

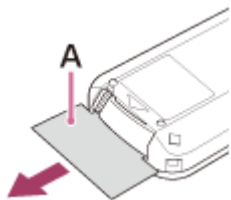

A: Insulation sheet

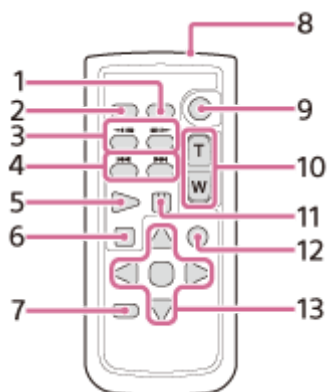

1. DATA CODE button
2. PHOTO button
3. SCAN/SLOW button
4. ◀◀/▶▶ (PREV/NEXT) button
5. PLAY button
6. STOP button
7. DISPLAY button
8. Transmitter
9. START/STOP button
10. Power zoom lever
11. PAUSE button
12. VISUAL INDEX button
13. ▲/▼/◀/▶/ENTER button

**Note**

- Aim the wireless remote commander towards the remote sensor to operate your camcorder.
- Point the remote sensor away from strong light sources such as direct sunlight or overhead lighting. Otherwise, the wireless remote commander may not function properly.
- When you are operating the camcorder with the supplied wireless remote commander, your video device may also operate. In that case, select a commander mode other than DVD2 for your video device, or cover the sensor of your video device with black paper.

Digital 4K Video Camera Recorder  
FDR-AX700

## Changing the battery of the wireless remote commander

---

- 1 While pressing on the tab, inset your fingernail into the slit to pull out the battery case.
- 2 Place a new battery with the + side facing up.
- 3 Insert the battery case until it clicks into place.



A: Tab

### Note

- When the lithium battery becomes weak, the operating distance of the wireless remote commander may shorten, or the wireless remote commander may not function properly. In this case, replace the battery with a Sony CR2025 lithium battery. Use of another battery may present a risk of fire or explosion.



## Screen indicators

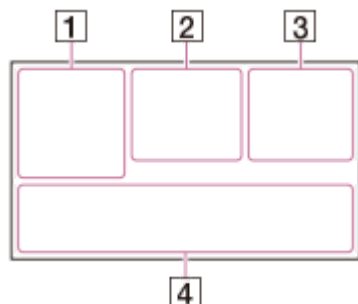

### Upper left (1)

- 100% Remaining battery
- Shooting mode
- INTELLIGENT AUTO (face detection/scene detection/camera-shake detection)
- SCENE SELECTION
- AVCHD 1080/60i EX XAVCS 1080/60p 50 REC FORMAT (Movie mode)
- 16:9 14.2M 3:2 12.0M Image size, aspect ratio (Photo mode)
- W T Optical zoom
- Z99 cQ W T x1.2 Clear image zoom
- Z99 dQ x2.3 Digital zoom
- SIMUL/RELAY REC
- 100-0001 Playback folder of memory card

### Center (2)

- AE/AF lock (Photo mode)
- Vibration warning
- Memory card
- REC STBY Recording status
- Warning
- Playback indicator
- Processing
- Relay recording
- HDMI REC CONTROL
- Proxy recording

### Upper right (3)

- 0 min Estimated remaining recording time
- Folder number where photos are saved
- 9999 Approximate number of recordable photos
- Recording/playback media
- 00:00:00:00 Time code (hour:minute:second:frame)
- 00 00 00 00 User bit (arbitrary digits)

### Bottom (4)

- FACE DETECTION [ON]
- PEAKING

ZEBRA  
 STEADYSHOT (Movie/Photo)  
 Manual focus  
 Picture profile  
 F5.6 Iris  
 1000/9dB ISO/Gain  
 100 180° Shutter speed  
 AVCHD AUDIO FORMAT  
 -2.0EV AE SHIFT  
 Auto setting/manual setting  
 White balance  
 LOW LUX  
 AUDIO LEVEL DISPLAY  
 AIRPLANE MODE  
 NFC is effective  
 D. EXTENDER  
 AUDIO REC LEVEL  
 NIGHTSHOT  
 MIC SELECT  
 ND FILTER  
 GAMMA DISP ASSIST



HISTOGRAM

## Data code during recording

The recording date, time and condition are recorded automatically. They are not displayed while recording. However, you can check them by selecting (DISPLAY SET) - [DATA CODE] and choosing the data that you want to display, or by pressing the ASSIGN button to which the DATA CODE function is assigned, during playback.

### Note

- Indicators may look different or appear at different positions.

Digital 4K Video Camera Recorder  
FDR-AX700

## Selecting the items on the LCD monitor

---

Use ▲ (move up) / ▼ (move down) / ◀ (move to the left) / ▶ (move to the right) / SET (to decide by pressing) on the menu that is displayed on the LCD monitor.

Some items are operated directly by touching the LCD monitor (SPOT METER/FOCUS, CALIBRATION ,etc.).

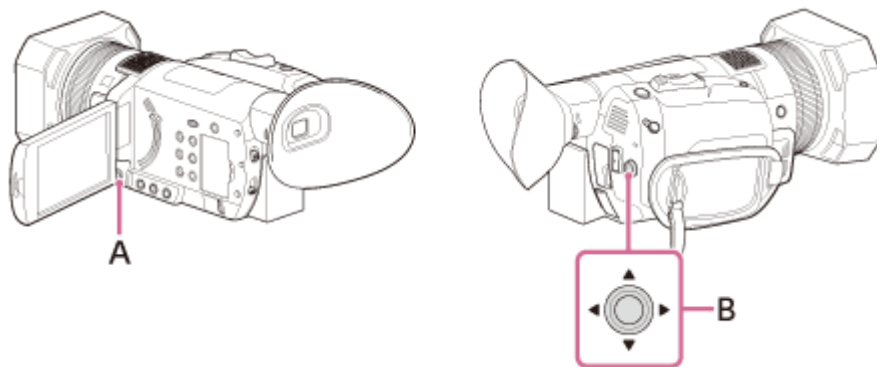

A: MENU button

B: ▲ / ▼ / ◀ / ▶ / SET button

Digital 4K Video Camera Recorder  
FDR-AX700

## Recording formats available with the camcorder and their features

---

The camcorder supports XAVC S 4K, XAVC S HD and AVCHD. The image quality of XAVC S 4K is 4-times greater than the conventional high definition image quality.

### XAVC S 4K

Recording pixels:

3,840 × 2,160 dots

Bit-rate:

100 Mbps, 60 Mbps

Feature:

Records in 4K. Even if you do not have a 4K TV, recording in 4K format is recommended for future purpose.

### XAVC S HD

Recording pixels:

1,920 × 1,080 dots

Bit-rate:

100 Mbps, 60 Mbps, 50 Mbps, 25 Mbps, 16 Mbps (When recording with S&Q MOTION: 50 Mbps or 25 Mbps)

Feature:

Allows you to record clearer images since XAVC S HD has more information compared with AVCHD.

### AVCHD

Recording pixels:

1,920 × 1,080 dots

Bit-rate:

Max. 24 Mbps

Feature:

Allows you to save images on devices other than computers.

#### Hint

- Bit-rate refers to the data amount recordable over a certain period of time.

---

#### Related Topic

- [REC SET](#)

Digital 4K Video Camera Recorder  
FDR-AX700

## Supplied items

---

Make sure that you have following items supplied with your camcorder. The numbers in ( ) indicate the supplied quantity.

Camcorder (1)

AC Adaptor (1)



Power cord (mains lead) (1)



USB cable (1)

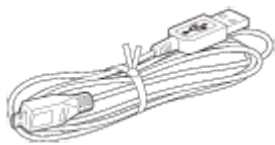

Wireless Remote Commander (1)



- A button-type lithium battery is already installed.
- Remove the insulation sheet before using the Wireless Remote Commander.

Large eyecup (1)



Lens hood (1)



Lens cap (Attached to lens) (1)



Rechargeable battery pack NP-FV70A (1)



- When using the camcorder while connected to a wall outlet (wall socket), such as while charging, make sure to attach the battery pack to the camcorder.

“Operating Guide” (1)

---

#### Related Topic

- [Parts and controls \(wireless remote commander\)](#)

Digital 4K Video Camera Recorder  
FDR-AX700

## Attaching the battery pack

Attach the battery pack to the camcorder.

- 1 Close the LCD monitor and retract the viewfinder , and then attach the battery pack ( ① ).
  - Align the indentation on the camcorder and projection on the battery pack, then slide the battery pack upwards.

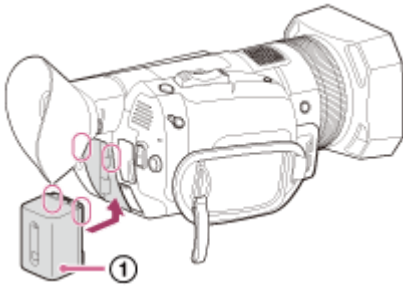

### To remove the battery pack

Turn off the camcorder. Slide the BATT (battery) release lever ( ① ) and remove the battery pack ( ② ).

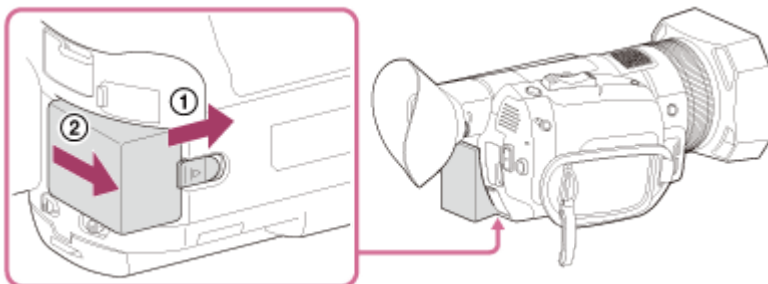

#### Note

- You cannot use any InfoLITHIUM battery pack other than the V series to the camcorder.

## Charging the battery pack using the AC Adaptor

Charge the battery pack using the supplied AC Adaptor. Attach the battery pack in advance.

**1** Close the LCD monitor .

- When the viewfinder is pulled out, retract it.

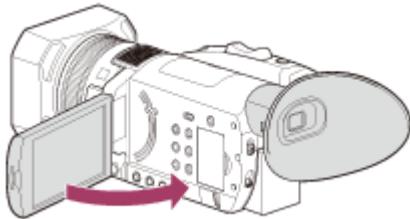

**2** Connect the AC Adaptor and the power cord (mains lead) to the camcorder and a wall outlet (wall socket).

- The POWER/CHG (charge) lamp lights orange.
- The POWER/CHG (charge) lamp turns off when the battery pack is fully charged. Disconnect the AC Adaptor from the DC IN jack of the camcorder.

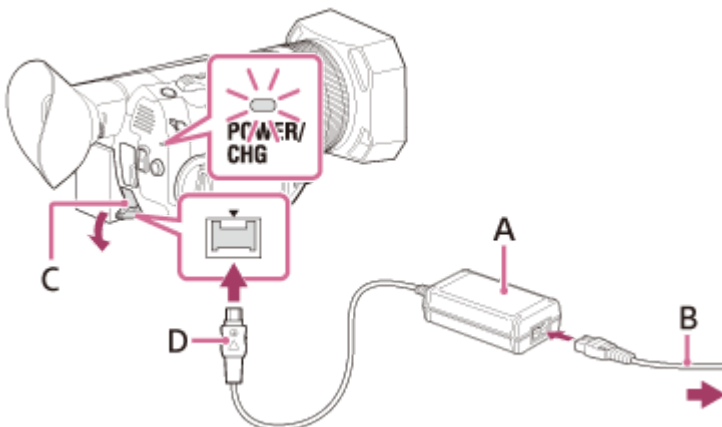

- A: AC Adaptor
- B: Power cord (mains lead)
- C: DC IN jack
- D: DC plug (Align the ▲ mark on the DC plug)

### Note

- Be aware of the following notes on using the AC Adaptor.
  - Use a nearby wall outlet (wall socket) when using the AC Adaptor. Disconnect the AC Adaptor from the wall outlet (wall socket) immediately if any malfunction occurs while using the camcorder.
  - Do not use the AC Adaptor placed in a narrow space, such as between a wall and furniture.
  - Do not short-circuit the DC plug of the AC Adaptor terminal with any metallic objects. This may cause a malfunction.

### Hint



- It is recommended that you charge the battery in a temperature range of 10°C to 30°C (50°F to 86°F).

---

---

#### Related Topic

- [Charging time](#)
- [Expected recording time with each battery pack](#)
- [Expected playback time with each battery pack](#)
- [Using the camcorder abroad](#)

4-725-312-11(2) Copyright 2017 Sony Corporation

## Turning the power on

Turn on the camcorder.

1 Open the LCD monitor of the camcorder and turn the power on.

- You can also turn on the camcorder by pressing  (On/Standby) button.

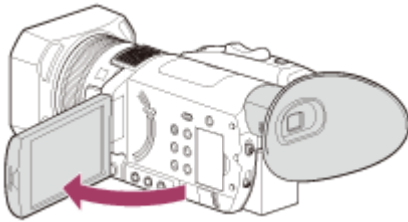

To turn off the power

Close the LCD monitor.

If the viewfinder is pulled out, retract the viewfinder as shown in the illustration below.

- You can also turn off the camcorder by pressing  (On/Standby) button.

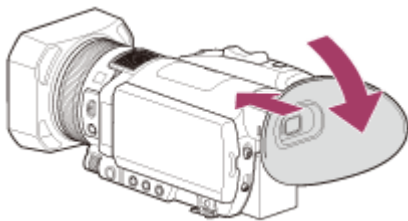

Turning the camcorder on or off

The power of the camcorder is turned on or off depending on the status of the LCD monitor or the viewfinder.

LCD monitor: Open

Power on, regardless of the viewfinder status (retracted or pulled out)

LCD monitor: Closed

Power off, when viewfinder is retracted

Power on, when viewfinder is pulled out

### Note

- Even if the LCD monitor is closed, if the viewfinder is pulled out, the camcorder is not turned off. When you turn off the power of the camcorder, make sure that the viewfinder is retracted to the original position.
- If warning messages appear on the LCD monitor, follow the instructions.
- When recording movies or when connected to another device via USB, the camcorder does not turn off even if the LCD monitor is closed and the viewfinder is returned to its original position.
- We recommend turning the camcorder off frequently by closing the LCD monitor or retracting the viewfinder to prevent consumption of the battery.



Digital 4K Video Camera Recorder  
FDR-AX700

## Using the camcorder supplying power from a wall outlet (wall socket)

---

You can supply power to the camcorder from a wall outlet (wall socket) by using the AC adaptor.

- 1 Operate the camcorder while it is connected to a wall outlet (wall socket) as shown in “ [Charging the battery pack using the AC Adaptor](#) .”
  - If you attach the battery pack to the camcorder while the AC adaptor is connected to the camcorder, the battery is not charged, but also not consumed.

---

### Related Topic

- [Charging the battery pack using the AC Adaptor](#)

## Adjusting the viewfinder

When using the viewfinder, extend it and position your eye near it.

If you extend the viewfinder while the LCD monitor is open, the display switches from the LCD monitor to the viewfinder when you position your eye near the viewfinder.

If the viewfinder image appears blurred, turn the lens adjustment dial next to the viewfinder until the image is sharp.

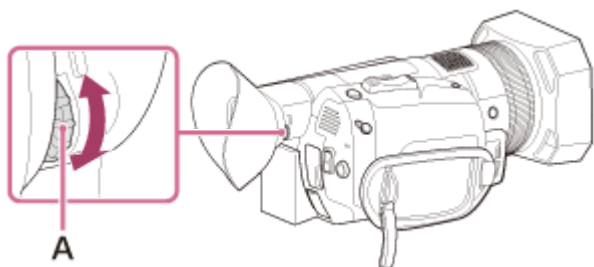

A: Lens adjustment dial

- Move it until the picture becomes clear.

### When the picture in the viewfinder is hard to see

If you cannot see the picture in the viewfinder clearly under bright circumstances, use the supplied large eyecup. To attach the large eyecup, stretch it slightly and fit it over the groove of the eyecup of the camcorder. You can attach the large eyecup facing either the right or left side.

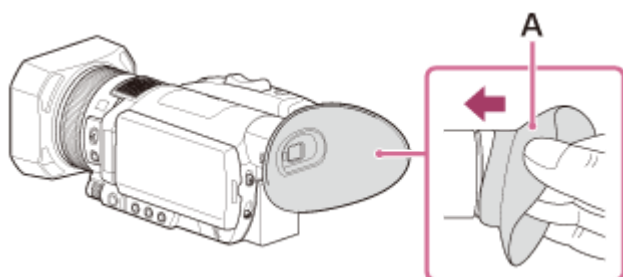

A: Large eyecup (supplied)

#### Note

- If the viewfinder is extended while the battery pack NP-FV100A (sold separately) is attached, the large eyecup and battery pack may interfere with each other slightly. However, this does not affect the functionality of the camcorder.

Digital 4K Video Camera Recorder  
FDR-AX700

## Adjusting the LCD monitor

---

The LCD monitor can be rotated in the range as illustrated below, allowing a person other than the camera operator to see the image.

If you rotate the LCD panel 180 degrees, you can close the LCD monitor with the screen facing out. This is convenient during playback operations.

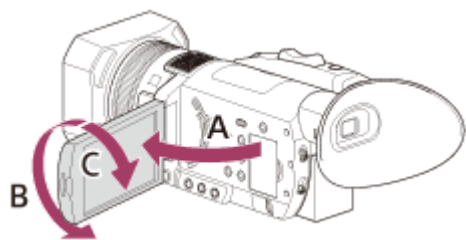

- A: Open 90 degrees.
- B: 180 degrees (max.)
- C: 90 degrees (max.)

## Initial setting

Set the language, date and time when using the camcorder for the first time.  
Perform the setting with the ▲ / ▼ / ◀ / ▶ / SET button.

- 1 Turn the camcorder on.

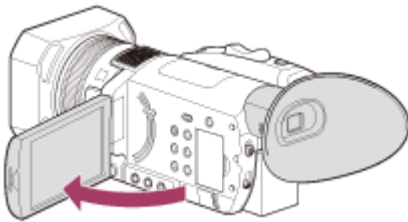

- 2 Select AREA SET , DST SET (SUMMERTIME), and DATE with the ▲ / ▼ / ◀ / ▶ / SET button.

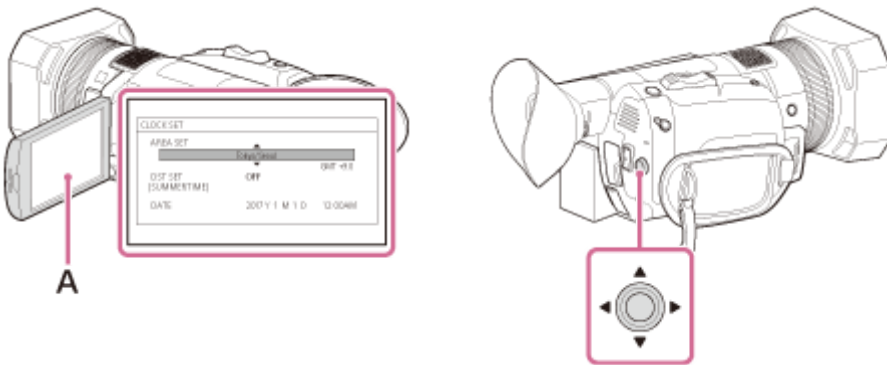

A: LCD monitor

- If you set [DST SET (SUMMERTIME)] to [ON], the clock advances 1 hour.
- You can set any year up to the year 2037.
- Midnight is indicated as 12:00 AM, and noon as 12:00 PM.

### Hint

- To change the screen language, press the MENU button and select (OTHERS) - [LANGUAGE].
- The date and time are recorded automatically and can be displayed only during playback. To display them, press the MENU button during playback, then select (DISPLAY SET) - [DATA CODE] - [DATE/TIME].

### Related Topic

- [DATA CODE](#)

Digital 4K Video Camera Recorder  
FDR-AX700

## Inserting a memory card

Insert a memory card into the camcorder.

- 1 Open the cover and insert the memory card until it clicks.

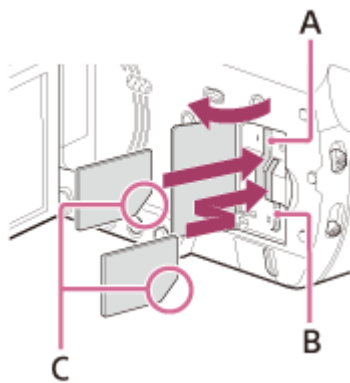

A: Memory card slot A

B: Memory card slot B

C: Insert the card with the notched edge in the direction as illustrated.

### Note

- To ensure stable operation of the memory card, it is recommended to format the memory card with the camcorder before the first use. Formatting the memory card will erase all the data stored on it and the data will be irrecoverable. Save your important data on your PC, etc.
- Confirm the direction of the memory card. If you forcibly insert the memory card in the wrong direction, the memory card, memory card slot, or image data may be damaged.
- Do not insert any memory card other than those that fit into the memory card slot. Doing so may cause a malfunction.
- Memory card slot A accepts either Memory Stick media or an SD card. Memory card slot B accepts an SD card only.
- When inserting or ejecting the memory card, be careful so that the memory card does not pop out and drop.
- Memory card will not be recognized by the camcorder unless it is inserted straight in the correct direction.
- If [Preparing image database file. Please wait.] is displayed, wait until the message disappears.
- If [The image database file is corrupted. The media must be restored to use again.] appears, perform [REPAIR IMAGE DB FILE].

### Hint

- To eject the memory card, open the cover and lightly push the memory card in once.

### Related Topic

- [Types of memory card you can use with your camcorder](#)
- [Expected recording time of movie](#)
- [Expected number of recordable photos](#)



- Selecting the memory card slot to be used for recording
- MEDIA FORMAT

4-725-312-11(2) Copyright 2017 Sony Corporation

Digital 4K Video Camera Recorder  
FDR-AX700

## Selecting the memory card slot to be used for recording

Press SLOT SELECT button to change which slot is selected for recording. You can confirm the selected slot on the LCD monitor.

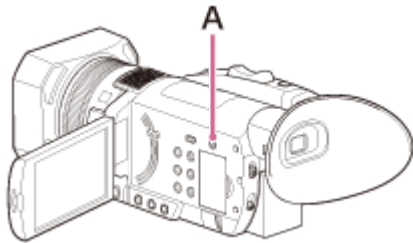

A: SLOT SELECT button

### Note

- You can only select a slot that already has a memory card inserted.
- While movies are being recorded on the memory card, you cannot switch the slot even if you press the SLOT SELECT button.

### Hint

- When only one slot has a memory card inserted, the slot that has the memory card is selected automatically (Movie mode only). In Photo mode, change the slot to which the memory card is currently inserted by pressing the SLOT SELECT button.

### Related Topic

- [Types of memory card you can use with your camcorder](#)

## Types of memory card you can use with your camcorder

The following types of memory cards can be used with the camcorder.

Select the type of memory card to use with the camcorder referring to the following table.

In this Help Guide, the types of memory cards you can use with the camcorder are called Memory Stick media or SD card.

### SD cards

Recording formats		Supporting memory cards
Photos		SD/SDHC/SDXC memory card
AVCHD		SD/SDHC/SDXC memory card (Class 4 or faster, or U1 or faster.)
XAVC S	4K 60Mbps* 4K 60Mbps* HD 50Mbps or less*	SDHC/SDXC memory card (Class 10 or faster, or U1 or faster.)
	4K 100Mbps* HD 100Mbps	SDHC/SDXC memory card (U3)
	S&Q MOTION	
	SUPER SLOW MOTION	SDHC/SDXC memory card (Class 10 or faster, or U1 or faster.)

\* Including in the Proxy recording mode.

### Memory Stick media

Recording formats	Supporting memory cards
Photos	Memory Stick PRO Duo media, Memory Stick PRO-HG Duo media
AVCHD	Memory Stick PRO Duo media (Mark2), Memory Stick PRO-HG Duo media
XAVC S	—

#### Note

- The movies recorded will be divided into files of 4 GB when an SDHC memory card is used to record XAVC S movies over extended periods of time. The divided files will be played back continuously when played back on the camcorder. The divided files can be integrated into the single file by using PlayMemories Home.
- Proper operation with all memory cards is not guaranteed. Contact the manufacturer of each memory card for the compatibility of memory cards other than Sony.
- When you use the camcorder with the Memory Stick Micro media or microSD memory card, insert into a dedicated card adaptor and connect it to the camcorder.

### Related Topic

- [Expected recording time of movie](#)

- [Expected number of recordable photos](#)
- [About the memory card](#)

4-725-312-11(2) Copyright 2017 Sony Corporation

Digital 4K Video Camera Recorder  
FDR-AX700

## Recording movies

Record movies.

Movies are recorded on the memory card and in XAVC S 4K format at the factory setting.

- 1 Press the latches on both sides of the lens cap and remove it.

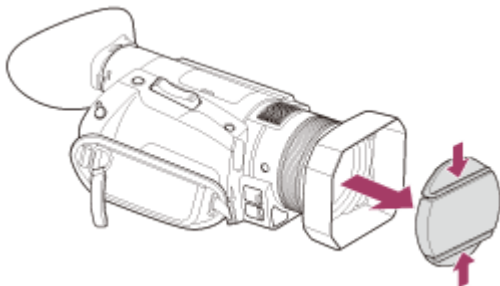

- 2 Open the LCD monitor of the camcorder and turn the power on.

- You can also turn on the camcorder by pressing the  (On/Standby) button or by pulling out the viewfinder (models with the viewfinder).

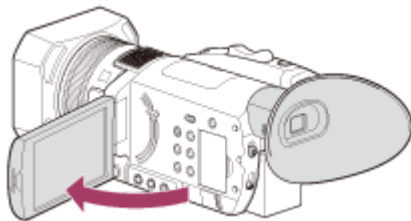

- 3 Press the START/STOP button to start recording.

- The recording lamp lights up during recording.
- To stop recording, press the START/STOP button again.

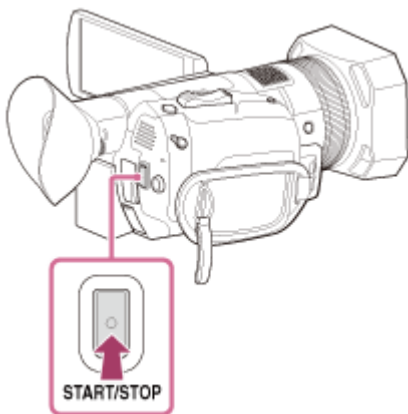

### Note

- The maximum continuous recordable time of a movie is about 13 hours.
- When an AVCHD movie file exceeds 2 GB, the next movie file is created automatically.

- When movie recording and outputting images to an external device (HDMI output) are performed simultaneously, [NIGHTSHOT LIGHT] is fixed to [OFF]. Also, when recording a movie with the [XAVC S 4K] 100Mbps setting or [XAVC S 4K] 60Mbps setting and outputting images to an external device (HDMI output) are performed simultaneously, [LCD BRIGHT] is fixed to [NORMAL].
- When the access lamp is lit or flashing in red, the camcorder is reading or writing data on the memory card. Do not shake or apply strong force to the camcorder, do not turn the power off, and do not remove the memory card, battery pack, or the AC Adaptor. The image data may be destroyed.
- The LCD monitor of the camcorder can display recording images across the entire monitor (full pixel display). However, this may cause slight trimming of the top, bottom, right, and left edges of images when played back on a TV which is not compatible with full pixel display. It is recommended you record images [MARKER] - [SAFETY ZONE] set to [80%] or [90%] using the displayed outer frame as a guide.
- The menu settings, picture profile settings, and settings made using the AUTO/MANUAL switch are stored when you close the LCD monitor and turn off the camcorder. The POWER/CHG (charge) lamp flashes while the settings are being stored.
- Check the subject on the LCD monitor, and then start recording.

#### Hint

- You can set the recording lamp not to turn on. Select [OFF] on  (OTHERS) - [REC LAMP].

---

#### Related Topic

- [Expected recording time of movie](#)
- [Selecting the memory card slot to be used for recording](#)
- [MARKER](#)
- [REC LAMP](#)
- [SHOOTING MODE](#)

## Continuing recording on the memory cards one after another (Relay recording)

The camcorder switches memory card A (or B) just before space on the other one runs out, and continues recording on the next memory card automatically by inserting memory cards each in both slots A and B (In Movie mode only). Do the following setting before recording.

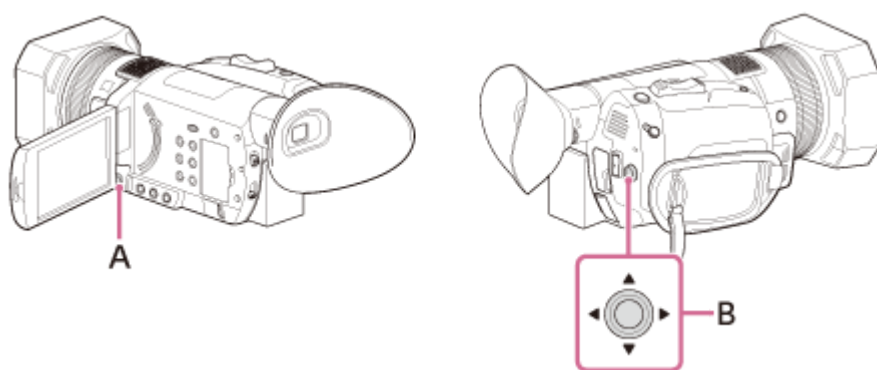

A: MENU button

B: ▲/▼/◀/▶/SET button

- 1 Press the MENU button.
- 2 Select  (REC/OUT SET) - [REC SET] - [SIMUL/RELAY REC] -[RELAY REC] with ▲/▼/◀/▶/SET button.

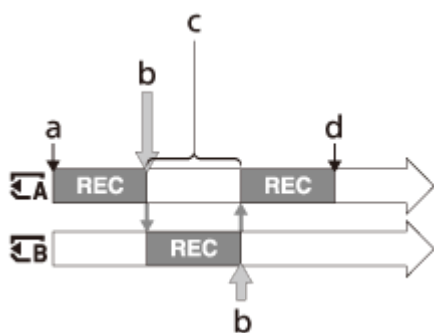

a: Start





b: Small space

c: Insert a recordable memory card

d: End

REC: Recording

### Note

- Do not eject the memory card that is currently being used for recording. When replacing a memory card while recording, replace only the one in the slot whose access lamp is off.
- Even if you press the SLOT SELCT button while recording movies, you cannot switch the slot currently being used.
- When the remaining recording time of the memory card being used is less than 1 minute and the other slot has recordable memory card inserted, [ A →  B] or [ B →  A] appears on the LCD monitor. The indicator turns off when the memory card is switched.
- The maximum continuous recordable time of a movie is about 13 hours.

- If you start recording on a memory card with the remaining recording time of less than 1 minute, the camcorder may not be able to perform Relay recording. To perform Relay recording without fail, make sure that the memory card has more than 1 minute when you start recording.
- You cannot play movies seamlessly on the camcorder when the movie is recorded with Relay recording on the camcorder.
- You can re-combine movies with Relay recording using the software PlayMemories Home.

---

#### Related Topic

- [Inserting a memory card](#)
- [Selecting the memory card slot to be used for recording](#)
- [Types of memory card you can use with your camcorder](#)
- [Import and utilize images on your computer \(PlayMemories Home\)](#)
- [REC SET](#)



Digital 4K Video Camera Recorder  
FDR-AX700

## Recording movies on both the memory card A and B (Simultaneous recording)

You can record movies on both the memory card A and B simultaneously.  
Make the following setting before recording (Movie mode only).

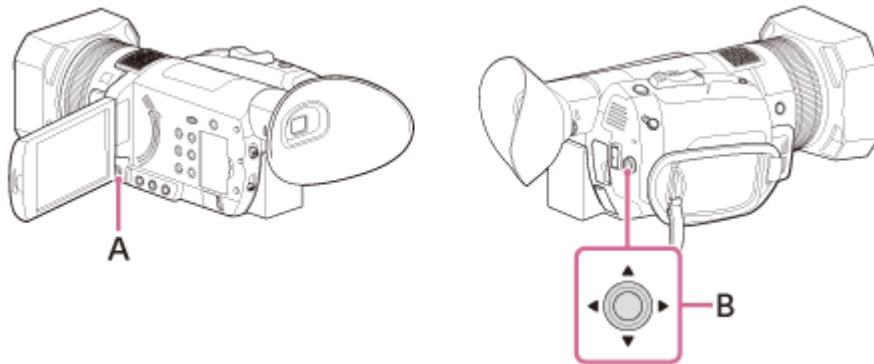

A: MENU button

B: ▲/▼/◀/▶/SET button

- 1 Press the MENU button.
- 2 Select  (REC/OUT SET) - [REC SET] - [SIMUL/RELAY REC] - [SIMULTANEOUS REC] with ▲/▼/◀/▶/SET button.

### Note

- You cannot perform Simultaneous recording when using the different types of memory cards for each slot.

### Related Topic

- [Inserting a memory card](#)
- [Selecting the memory card slot to be used for recording](#)
- [Types of memory card you can use with your camcorder](#)
- [REC SET](#)

## Shooting photos

Shoot photos.

- 1 Press the latches on both sides of the lens cap and remove it.

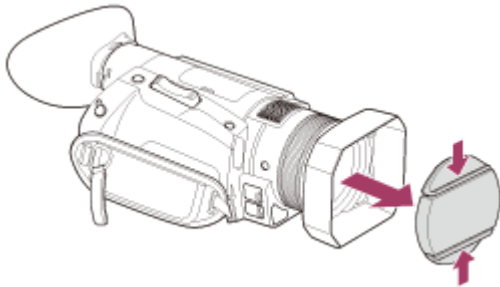

- 2 Open the LCD monitor of the camcorder and turn the power on.

- You can also turn on the camcorder by pressing  (On/Standby) button or by pulling out the viewfinder.

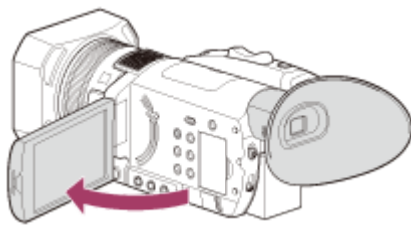

- 3 Press the MENU button.

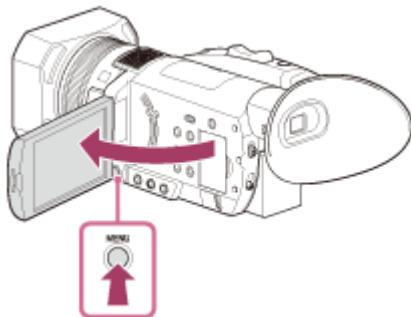

- 4 Select  (REC/OUT SET) - [/] SHOOTING MODE] - [PHOTO] with  /  /  /  / SET button.

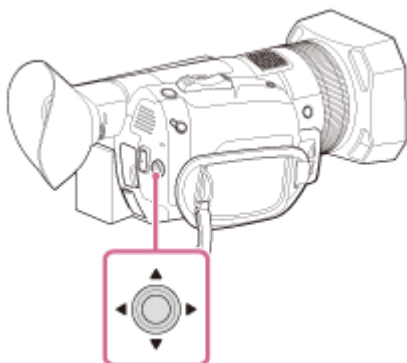

5 Press the PHOTO button lightly to adjust the focus, then press it fully .

- When the focus is adjusted properly, the AE/AF lock indicator appears on the LCD monitor and the ISO value appears when the ISO display is set to AUTO.

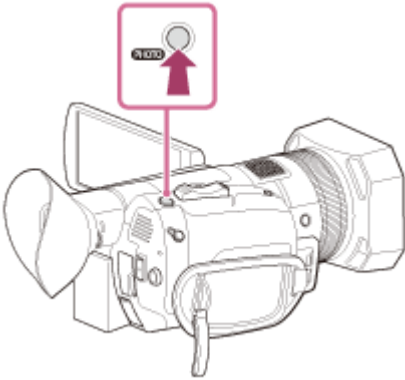

#### Note

- You cannot shoot photos when the camcorder is in Movie mode.
- When the access lamp is lit or flashing in red, the camcorder is reading or writing data on the memory card. Do not shake or apply strong force to the camcorder, do not turn the power off, and do not remove the memory card, battery pack, or the AC Adaptor. The image data may be destroyed.

---

#### Related Topic

- [SHOOTING MODE](#)
- [IMAGE SIZE](#)
- [Expected number of recordable photos](#)

## Adjusting the zoom with the zoom lever

Press the zoom lever slightly to zoom slowly, and press it further to zoom more quickly.

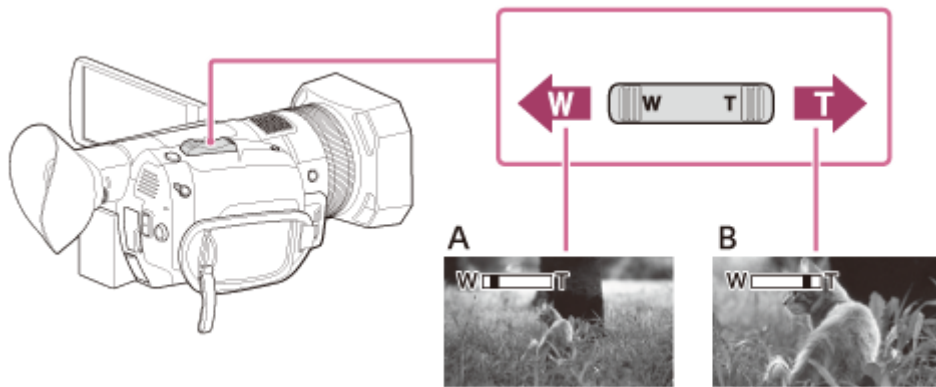

A: Wide view (Wide angle)

B: Close view (Telephoto)

### Hint

- When focusing, the minimum distance required between the camcorder and the subject is about 1 cm (about 13/32 in.) for wide angle and about 1 meter (about 39 3/8 in.) for telephoto.
- The focus may not be adjusted at certain zoom positions if the subject is within 1 meter (about 39 3/8 in.) from the camcorder.
- Be sure to keep your finger on the zoom lever. If you move your finger off the zoom lever, the operation sound of the zoom lever may also be recorded.
- You can increase the zoom speed of the zoom lever. Select MENU button – (CAMERA SET) – [ZOOM SET] - [SPEED ZOOM].

### Related Topic

- [ZOOM SET](#)
- [ZOOM DISPLAY](#)

Digital 4K Video Camera Recorder  
FDR-AX700

## Adjusting the zoom with the manual lens ring

You can zoom at the desired speed by turning the manual lens ring by setting the ZOOM/FOCUS switch to ZOOM. Fine adjustment is also possible.

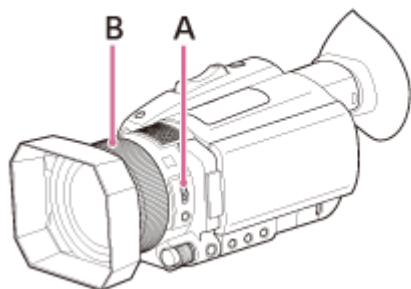

A: ZOOM/FOCUS switch

B: Manual lens ring

### Note



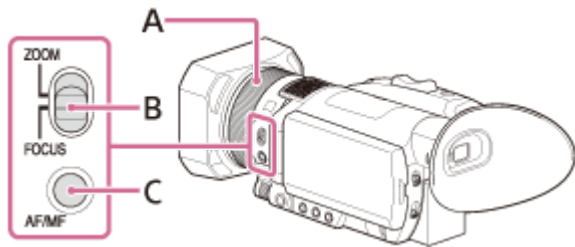

- Turn the manual lens ring at a moderate speed. If you turn it too fast, the zoom speed may lag behind the manual lens ring rotation speed, or the operation sound of the zoom may also be recorded.

## Adjusting the focus manually

You can adjust the focus manually.



- A: Manual lens ring
- B: ZOOM/FOCUS switch
- C: AF/MF button

- 1 During recording or standby , press the AF/MF button to set the focus to manual.
  -  appears.
- 2 Set the ZOOM/FOCUS switch to FOCUS, and turn the manual lens ring.
  - FOCUS: Adjusts the focus manually by turning the manual lens ring.
  - ZOOM: Adjust the zoom manually by turning the manual lens ring.
    -  changes to  when the focus cannot be adjusted any further, or changes to  when the focus cannot be adjusted any closer.

### Hint

- You can change this setting directly with  /  /  /  / SET button on the shooting standby screen (Direct Menu).

### Related Topic

- [FOCUS DISPLAY](#)
- [Performing shooting adjustment with Direct Menu](#)

Digital 4K Video Camera Recorder  
FDR-AX700

## Adjusting the focus automatically

You can adjust the focus automatically in accordance with the situation.

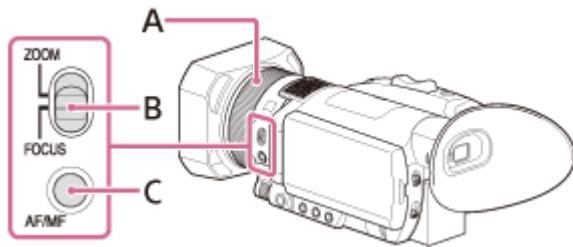



- A: Manual lens ring  
B: ZOOM/FOCUS switch  
C: AF/MF button

- 1 Press the AF/MF button to set the focus to automatic.
  -  disappears and the auto focus adjustment is effective.
  - When the phase detection AF function is effective, the phase detection AF frames appear (only when [PHASE AF FRAMES] is set to [ON]). White frames are the area to where the camcorder tries to focus. Frame color changes to green after focusing.

### Note

- In the Super Slow Motion recording mode, auto focus function is not available. Adjust the focus manually.

### Hint

- The focal length information (the distance at which the subject is in focus; for when it is dark and hard to adjust the focus) appears for about 3 seconds in the following cases.
  - When you press AF/MF button to set the focus to manual and  appears.
  - When you rotate the manual lens ring while  appears.
- You can switch the focal length information between meters and feet. Select the unit on MENU button -  (DISPLAY SET) - [FOCUS DISPLAY].
- You can change the focus position for auto focus mode during movie recording.
- You can select the focus speed for auto focus mode during movie recording.
- You can select AF tracking sensitivity for auto focus mode during movie recording.
- You can set whether to display the phase detection AF frames that appear when the phase detection AF function is effective.

### Related Topic

- [Adjusting the focus manually](#)
- [FOCUS DISPLAY](#)
- [FOCUS AREA](#)
- [AF DRIVE SPEED](#)

- AF SUBJ. TRACK SET
- PHASE AF FRAMES

4-725-312-11(2) Copyright 2017 Sony Corporation



## FOCUS AREA

You can change the focusing area for auto focus mode (Movie mode only). Use this function when the layout or range of moving subject is decided in advance, or it is difficult to focus on the intended subject.

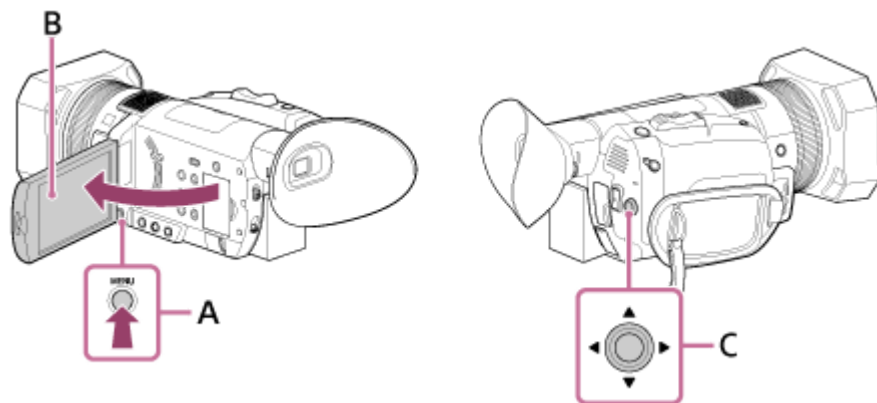

- A: MENU button  
B: LCD monitor  
C: ▲/▼/◀/▶/SET button

- 1 Press the MENU button.
- 2 Select  (CAMERA SET) - [ FOCUS AREA] with the ▲/▼/◀/▶/SET button.

### Description of menu items

#### WIDE:

Focuses on a subject covering the whole range of the screen automatically.

You can specify the subject that you want to focus by touching it during the phase detection AF frames appear.

- Touch operation is possible only when [LOCK-ON AF] is set to [OFF].
- When [FACE DETECTION] is set to [ON], the focus area is not displayed and touch operation is disabled.

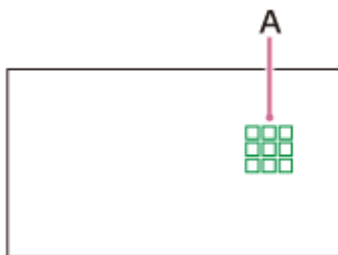

#### A: Phase detection AF frames

White frames are the area to where the camcorder tries to focus. The frame color changes to green after becoming in focus.

#### ZONE:

Select a zone by touching on the area selection screen or using the ▲/▼/◀/▶/SET button. The camcorder then focuses automatically in the zone.

The zone is divided 3 rows and 3 columns (9 zones).

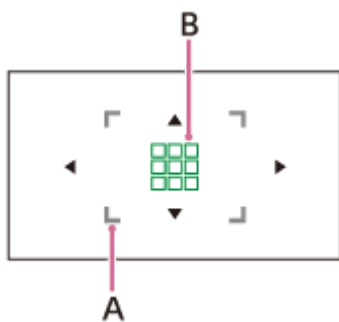

A: Focus area

Indicates the area where the auto focus works.

B: Phase detection AF frames

White frames are the area to where the camcorder tries to focus. The frame color changes to green after becoming in focus.

CENTER:

Focuses automatically on a subject in the center of the image.

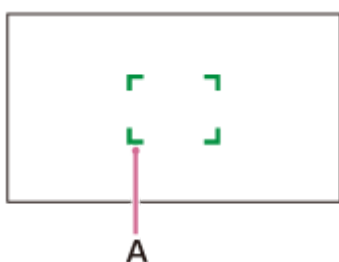

A: Focus frame

Indicates the area where the auto focus works.

The frame color is gray while the camcorder tries to focus on the subject and it turns to green when the subject is in focus.

FLEXIBLE SPOT :

Move the focus frames to a desired point by touching on the area selection screen or using the ▲ / ▼ / ◀ / ▶ / SET button. You can focus on a small subject in a narrow area.

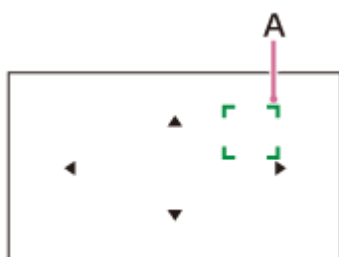

A: Focus frame

Indicates the area where the auto focus works.

The frame color is gray while the camcorder tries to focus on the subject and it turns to green when the subject is in focus.

### Note

- [FOCUS AREA] is fixed to [WIDE] on the following cases.
  - Using the clear image zoom or digital zoom.
  - [INTELLIGENT AUTO] or [SCENE SELECTION] is set for [AUTO MODE SET].
  - LOCK-ON AF is set.
- [FOCUS AREA] setting is not available in Super Slow Motion recording.
- The [FOCUS AREA] setting is not enabled when using a zoom other than the optical zoom and the focus area frames are displayed as a dotted line.

## Hint

- You can select the focus speed for auto focus mode during movie recording.
- You can select AF tracking sensitivity for auto focus mode during movie recording.
- You can assign [FOCUS AREA] to the ASSIGN button.
- When [FOCUS POSITION] is assigned to the ASSIGN button and [FOCUS AREA] is set to [FLEXIBLE SPOT] or [ZONE], you can display the area selection screen directly by pressing the button.
- You can set whether to display the phase detection AF area or phase detection AF frames.

---

## Related Topic

- [Adjusting the focus automatically](#)
- [Phase detection AF](#)
- [AF DRIVE SPEED](#)
- [AF SUBJ. TRACK SET](#)
- [PHASE AF FRAMES](#)
- [PHASE DETECT. AF AREA](#)
- [Assigning the functions to the ASSIGN buttons](#)

## Phase detection AF

---

When there are phase detection AF points within the auto focus area, the camcorder uses the combined autofocus of the phase detection AF and contrast AF.

### Note

- The phase detection AF is not effective under the following conditions. Only the contrast AF is effective.
  - During Photo mode.
  - When [FILE FORMAT] is [XAVC S HD] and [REC FORMAT] is 120p/100p.
  - When [HIGH FRAME RATE] is selected in [S&Q MOTION].
  - When [NIGHTSHOT] is set to [ON].
  - When the iris value is F8.0 or more.
- Auto focus function is not available in the Super Slow Motion recording mode.

### Hint

- We recommend to use the ND filter when the iris value is F8.0 or more at an outdoor light place, etc.

Digital 4K Video Camera Recorder  
FDR-AX700

## AF DRIVE SPEED

---

You can select the auto focus speed during recording movies.

- 1 MENU button -  (CAMERA SET) - [AF DRIVE SPEED].

### Descriptions of menu items

1[SLOW] - 7[FAST]:

Sets the auto focus speed.

When setting to the slow side, the excessive focus movement is reduced. The focus switches smoothly when the subject to be focused is changed and shooting impressive images is possible. This is suitable for shooting a scene in constant motion or a scene where an object does not move too much.

When setting to the fast side, the AF drive speed is set to fast and you can keep focusing on the subject with fast movement. This is suitable for shooting active scenes, such as sports. The larger the value you set, the faster the AF drive speed.

#### Note

- This setting is not available under the following conditions.
  - When [NIGHTSHOT] is set to [ON].
  - When [FILE FORMAT] is [XAVC S HD] and [REC FORMAT] is 120p/100p.
  - When [HIGH FRAME RATE] is selected in [S&Q MOTION].
- The auto focus function is not available in the Super Slow Motion recording mode.

#### Hint

- You can assign this function to the ASSIGN button.

---

### Related Topic

- [Assigning the functions to the ASSIGN buttons](#)

Digital 4K Video Camera Recorder  
FDR-AX700

## AF SUBJ. TRACK SET

You can set the auto focus range to track a subject or auto focus sensitivity to switch between subjects during movie recording.

- 1 MENU button -  (CAMERA SET) - [AF SUBJ. TRACK SET] - select the desired item.

### Descriptions of menu items

#### AF TRACKING DEPTH :

Sets the AF tracking area for the subject in the depth direction.

- 1[NARROW] to 5[WIDE]: Set to the Wide side when shooting the subject with large motion in the depth direction. Set to the Narrow side when shooting the subject that does not move so much.  
When setting to the Wide side, you can focus on subjects whose distance from the camera changes one after another. The larger the setting value you set, the faster the focusing another subject.  
When setting to the Narrow side, you can keep focusing the desired subject under the condition where the another subject crosses the desired subject. It is suitable for keeping focusing the desired subject.

#### AF SUBJ. SWITCH. SENS.:

Sets the switching time to focus another subject when the subject is switched or is not tracked because the subject moves out from the focus area.

- 1[LOCKED ON] - 5[RESPONSIVE]: Set to the Locked on side when shooting one subject. Set to the Responsive side when shooting plurality of subjects.  
When setting to the Responsive side, you can focus subjects one after another when the subject is switched. The larger the setting value you set, the faster the focusing another subject.  
When setting to the Locked on side, you can keep focusing the desired subject because the tracking does not respond quickly even if the subject moves out from the focus area. It is suitable for keeping focusing the desired subject.

### Setting example of AF TRACKING DEPTH/AF SUBJ. SWITCH. SENS.

- Trains/races:  
Situation that you want to track the subject with fast and regular motion and nothing exists in front of it.  
AF TRACKING DEPTH: 4 / AF SUBJ. SWITCH. SENS.: 5
- Sports/wild animals:  
Situation that you want to keep tracking the particular subject with fast and irregular motion.  
AF TRACKING DEPTH: 4/ AF SUBJ. SWITCH. SENS.: 2
- Landscape/macro :  
Situation that you want to focus on the subject without delay which contains less motion but much scene changes.  
AF TRACKING DEPTH: 1/ AF SUBJ. SWITCH. SENS.: 5
- Party/festival:  
Situation that you want to keep tracking a particular subject with moderate motion, or situation which contains persons in front who are not main subject.  
AF TRACKING DEPTH: 1/ AF SUBJ. SWITCH. SENS.: 1

#### Note

- This setting is not available under the following conditions.
  - When [NIGHTSHOT] is set to [ON].
  - When [FILE FORMAT] is [XAVC S HD] and [REC FORMAT] is 120p/100p.
  - When [HIGH FRAME RATE] is selected in [S&Q MOTION].
- Auto focus function is not available in the Super Slow Motion recording mode.

## Hint

- You can assign this function to the ASSIGN button.

---

## Related Topic

- [Assigning the functions to the ASSIGN buttons](#)

4-725-312-11(2) Copyright 2017 Sony Corporation

## Adjusting focus by tracking the desired subject ( LOCK-ON AF)

You can track a subject you select and adjust the focus automatically.

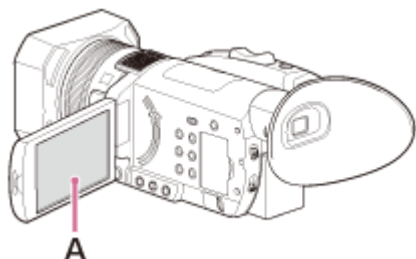

A: LCD monitor

1 Touch the subject you want to track while recording.

- To cancel the Lock-on AF function, select .

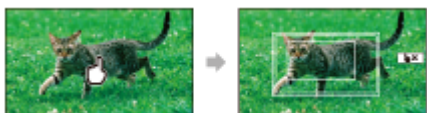

### Note

- Lock-on AF function is not available when [LOCK-ON AF] is set to [OFF].
- Lock-on AF function may not work properly under the following conditions.
  - Movement of the subject is too fast.
  - The subject is too small or too large.
  - The color of the subject and background is similar.
  - Dark scene.
  - The scene whose brightness changes.
- This setting is not available under the following conditions.
  - During using clear image zoom or digital zoom
  - During using [D. EXTENDER]
  - During manual focus set by pressing the AF/MF button ( appears on the screen)
  - [COLOR BAR] is set to [ON].
  - When [FILE FORMAT] is set to [XAVC S HD] and [REC FORMAT] is 120p/100p.
  - When [FILE FORMAT] is set to [XAVC S 4K] and [PROXY REC MODE] is [ON].
  - When [FILE FORMAT] is set to [XAVC S 4K] and [4K REC OUTPUT] is set to [EXTERNAL OUTPUT].
  - When [HIGH FRAME RATE] is set to [ON] in [S&Q MOTION].
  - During [SUPER SLOW MOTION] recording.
- You may not able to restart tracking the subject for a certain period of time after losing the tracking subject.

### Hint

- [FOCUS AREA] is fixed to [WIDE] during using LOCK-ON AF.



- LOCK-ON AF
- FOCUS AREA

4-725-312-11(2) Copyright 2017 Sony Corporation

## Focusing by magnifying an image ( FOCUS MAGNIFIER)

The selected area on the LCD monitor is magnified and displayed. This is useful to check that the subject is in focus.

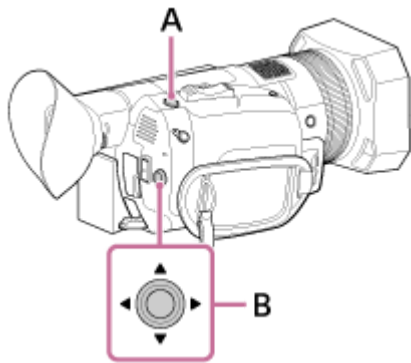

A: FOCUS MAGNIFIER button (assigned to the ASSIGN4 button by default)

B: ▲/▼/◀/▶/SET button

1 Press the FOCUS MAGNIFIER button.

- The center of the screen is magnified.
- The setting changes with each press of the button.



A: Enlarged display position

You can adjust the enlarged display position with ▲/▼/◀/▶ button. Press the SET button to set the enlarged display position back to the center.

### Note

- Even though the image appears expanded on the LCD monitor, the recorded image is not expanded.

### Hint

- You can change the magnification ratio with [FOCUS MAG RATIO].

### Related Topic

- [FOCUS MAG RATIO](#)
- [Assigning the functions to the ASSIGN buttons](#)



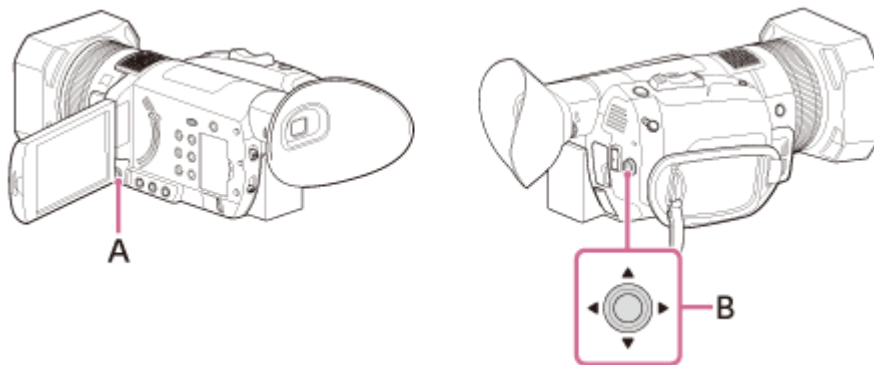

## Focusing by touching the LCD monitor ( SPOT FOCUS)

You can focus on the point where you touch on the LCD monitor.



A: MENU button

B: ▲ / ▼ / ◀ / ▶ / SET button

- 1 Set the **AUT O/MANUAL** switch to **MANUAL** and press the **AF/MF** button to set the focus mode to manual (MF).
  -  appears.
- 2 Press the **MENU** button.
- 3 Select  (**CAMERA SET**) - [**SPOT FOCUS**] with **▲ / ▼ / ◀ / ▶ / SET** button.
- 4 Touch the point to be focused on the LCD monitor .

### To cancel the spot focus

Press the **MENU** button.

#### Note

- [SPOT FOCUS] is available only with manual focus.
- Spot focus function is not available in Super Slow Motion recording.

#### Hint

- You can assign this function to an **ASSIGN** button.

### Related Topic

- [SPOT FOCUS](#)
- [Assigning the functions to the ASSIGN buttons](#)



## Focusing on a detected face ( FACE DETECTION)

The camcorder detects the face and focuses on it (the default setting is [ON]). This function is available only with auto focus.

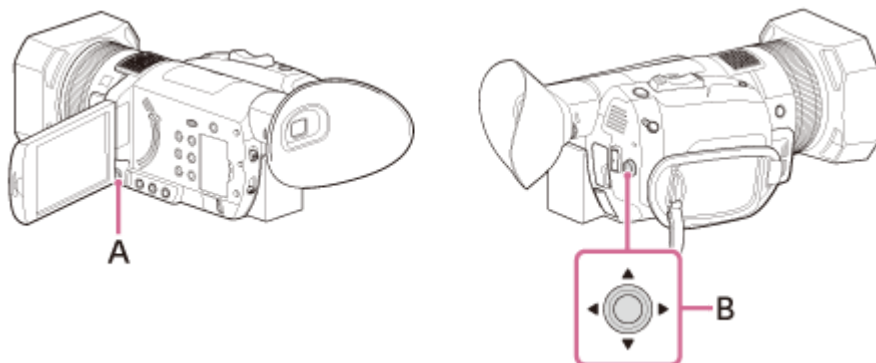

A: MENU button

B: ▲ / ▼ / ◀ / ▶ / SET button

- 1 Press the MENU button.
- 2 Select  (CAMERA SET) - [FACE DETECTION] - [ON] with the ▲ / ▼ / ◀ / ▶ / SET button.
  - When the faces are detected, frames(\*) appear.
    - \* When the faces are detected, gray face-detection frames appear. When the camcorder is in the status to be able to perform autofocus, the frame turns white. When [PHASE AF FRAMES] is set to [ON ], or you press the PHOTO button halfway and the face is in focus, the frame turns green.
- 3 Move the selection cursor (orange underline) to select the priority face with the ▲ / ▼ / ◀ / ▶ / SET button, then press the button to enter .



A: Selection cursor (orange colored frame)

B: Priority face frame (double frame)

The frame on the priority face changes to a double frame.

To cancel the priority face

Move the selection cursor (orange underline) to the frame (double frame) on the priority face with the ▲ / ▼ / ◀ / ▶ / SET button, then press it.

### Note

- Faces may not be detected or the proper effect may not be obtained depending on the recording environment, the condition of the subject or the settings. If this happens, set [FACE DETECTION] to [OFF].
- When [LOCK-ON AF] is set to [ON], the selection cursor does not appear and you cannot select priority face.
- The face detection function is disabled when using digital zoom, clear image zoom or NIGHTSHOT.

#### Hint

- Faces within the area that is set on [FOCUS AREA] are detected and focused.
- The focus area frame does not appear when [FOCUS AREA] is set to [WIDE] and [FACE DETECTION] is set to [ON].
- You can assign this function to an ASSIGN button.
- To make it easy to detect faces, record under the following conditions.
  - Record in a moderately bright place
  - Do not obscure the face with a hat, mask, sunglasses, etc.
  - Face the front of the camera

---

#### Related Topic

- [FACE DETECTION](#)
- [FOCUS AREA](#)
- [Assigning the functions to the ASSIGN buttons](#)

## Adjusting the iris

This is useful for making the background blurred or sharp.

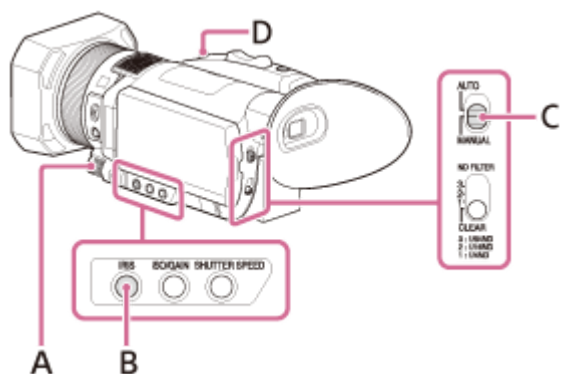

- A: Manual dial  
 B: IRIS button  
 C: AUTO/MANUAL switch  
 D: IRIS PUSH AUTO button (assigned to the ASSIGN5 button by default)

1 Set the AUTO/MANUAL switch to MANUAL.

2 Press the IRIS button.

- The **A** or **E** next to the iris value disappears, and the iris value is highlighted.

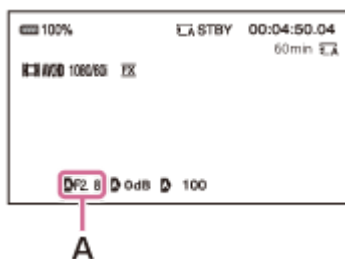

A: Iris value

3 Turn the manual dial to adjust the value and press the **▲/▼/◀/▶/SET** button to enter .

- The light quantity increases the more that you open the aperture (decreasing iris value). The light quantity decreases the more that you close the aperture (increasing iris value).

### To temporarily adjust the iris automatically

Hold the IRIS PUSH AUTO button down.

The iris is adjusted automatically for as long as you hold the button down.

### To adjust the iris automatically

Press the IRIS button while the iris value is highlighted.

The iris value disappears or **A** appears next to the iris value. When AE is fixed, **E** appears next to the iris value.



### Note

- When you set the AUTO/MANUAL switch to AUTO, the iris, gain, ISO sensitivity, shutter speed, and white balance are adjusted automatically. You cannot adjust them manually.

### Hint

- You can change this setting directly with the ▲ / ▼ / ◀ / ▶ / SET button on the shooting standby screen (Direct Menu).

---

---

### Related Topic

- [Performing shooting adjustment with Direct Menu](#)

4-725-312-11(2) Copyright 2017 Sony Corporation

## Adjusting the gain

You can use this if you do not want to increase the value by AGC (automatic gain control) during recording movies.

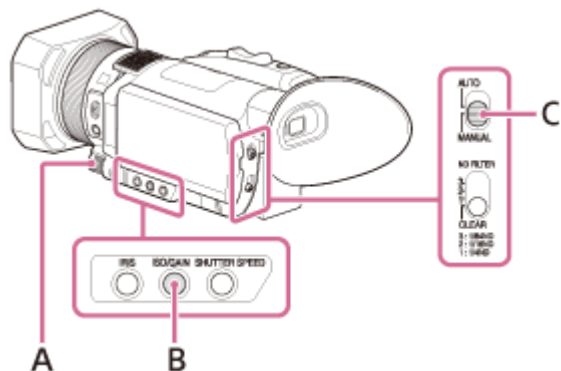

- A: Manual dial
- B: ISO/GAIN button
- C: AUTO/MANUAL switch

- 1 Check that the camcorder is in Movie mode.
- 2 Set the AUTO/MANUAL switch to MANUAL.
- 3 Press the ISO/GAIN button.
  - The **A** or **E** next to the gain value disappears, and the gain value is highlighted.

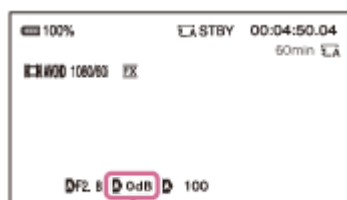

A: Gain value

- 4 Turn the manual dial to adjust the value and press the **▲/▼/◀/▶/SET** button to enter .

### To adjust the gain automatically

Press ISO/GAIN button while the gain value is highlighted.

The gain value disappears, or **A** appears next to the gain value. When AE is fixed, **E** appears next to the gain value.

#### Note

- When you set the AUTO/MANUAL switch to AUTO, the iris, gain, ISO sensitivity, shutter speed, and white balance is adjusted automatically. You cannot adjust them manually.
- The adjusted screen for the ISO sensitivity appears during Photo mode.

## Hint

- You can change this setting directly with ▲ / ▼ / ◀ / ▶ / SET button on the shooting standby screen (Direct Menu).

---

## Related Topic

- [ISO/GAIN SEL](#)
- [AGC LIMIT](#)
- [Performing shooting adjustment with Direct Menu](#)

4-725-312-11(2) Copyright 2017 Sony Corporation

## Adjusting the ISO sensitivity

You can use this if you do not want to increase the value by AUTO ISO LIMIT.

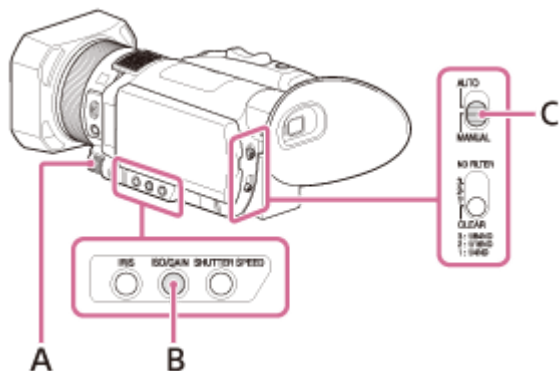

- A: Manual dial
- B: ISO/GAIN button
- C: AUTO/MANUAL switch

- 1 Set [ISO/GAIN SEL] to [ISO].
- 2 Set the AUTO/MANUAL switch to MANUAL.
- 3 Press the ISO/GAIN button.
  - The **A** or **E** next to the ISO value disappears, and the ISO value is highlighted.

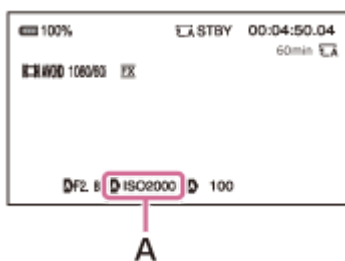

A: ISO value

- 4 Turn the manual dial to adjust the value and press the **▲/▼/◀/▶/SET** button to enter .

### To adjust the ISO sensitivity automatically

Press the ISO/GAIN button while the ISO value is highlighted.

The ISO value disappears, or **A** appears next to the ISO value. When AE is fixed, **E** appears.

#### Note

- When you set the AUTO/MANUAL switch to AUTO, the iris, gain, ISO sensitivity, shutter speed, and white balance is adjusted automatically. You cannot adjust them manually.
- In Movie mode, both ISO or gain can be displayed.
- You can adjust the ISO sensitivity in Movie mode.

## Hint

- You can change this setting directly with the ▲ / ▼ / ◀ / ▶ /SET button on the shooting standby screen (Direct Menu).

---

## Related Topic

- [ISO/GAIN SEL](#)
- [AUTO ISO LIMIT](#)
- [Performing shooting adjustment with Direct Menu](#)

4-725-312-11(2) Copyright 2017 Sony Corporation

## Adjusting the shutter speed

You can adjust and fix the shutter speed manually.

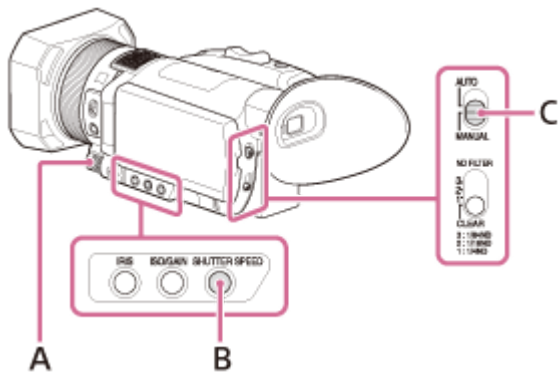

- A: Manual dial  
B: SHUTTER SPEED button  
C: AUTO/MANUAL switch

- 1 Set the AUTO/MANUAL switch to MANUAL.
- 2 Press the SHUTTER SPEED button.
  - The **A** or **E** next to the shutter speed value disappears, and the shutter speed value is highlighted.

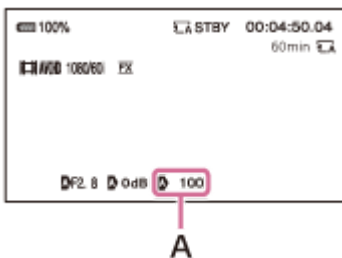

A: Shutter speed value

- 3 Turn the manual dial to adjust the value and press the **▲/▼/◀/▶/SET** button to enter .
  - For example, [100] appears on the LCD screen when you set the shutter speed to 1/100 second. The larger the value is, the faster the shutter speed is.
  - The setting items differ depending on the setting of **☰** (OTHERS) - [60i/50i SEL].  
When selecting [ 60i]:  
You can select from 1/8 to 1/10000 (from 1/6 to 1/10000 when recording with 24p).  
When selecting [ 50i]:  
You can select from 1/6 to 1/10000.

### To adjust the shutter speed automatically

Press the SHUTTER SPEED button while the shutter speed value is highlighted.

The shutter speed value disappears or **A** appears next to the shutter speed value. When AE is fixed, **E** appears.

## Note

- When you set the AUTO/MANUAL switch to AUTO, the iris, gain, ISO sensitivity, shutter speed, and white balance is adjusted automatically. You cannot adjust them manually.

## Hint

- It is difficult to focus automatically at a lower shutter speed. We recommend to perform manual focusing with the camcorder attached to a tripod, or etc.
- When shooting under fluorescent lamps, sodium lamps, or mercury lamps, the picture may flicker or change colors, or may have horizontal bands of noise. You may be able to improve the situation by adjusting the shutter speed.
- You can switch the shutter speed display between seconds and degrees on [SHUTTER DISPLAY].
- You can change this setting directly with the ▲ / ▼ / ◀ / ▶ / SET button on the shooting standby screen (Direct Menu).

---

## Related Topic

- [60i/50i SEL](#)
- [SHUTTER DISPLAY](#)
- [Performing shooting adjustment with Direct Menu](#)

## Adjusting the light quantity (ND filter)

You can record the subject clearly by using the ND FILTER switch when the recording environment is too bright. The ND filters 1, 2, and 3 reduce the light quantity to about 1/4, 1/16 and 1/64, respectively.

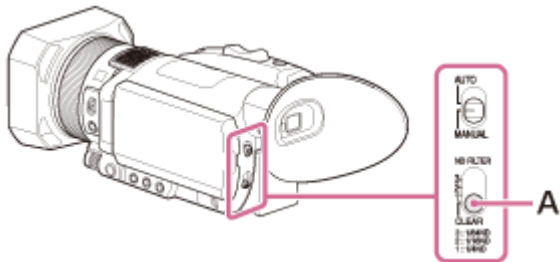

A: ND FILTER switch

If **ND1** flashes during the iris automatic adjustment, set the ND filter to 1. If **ND2** flashes during the iris automatic adjustment, set the ND filter to 2. If **ND3** flashes during the iris automatic adjustment, set the ND filter to 3. The ND filter indicator will stop flashing and remain on the screen. If **NDOFF** flashes, set the ND FILTER switch to CLEAR. The ND filter indicator disappears.

### Note

- If you switch the ND FILTER switch during recording, the movie and sound may be distorted.
- When adjusting the iris manually, the ND filter indicator does not flash even if you need to adjust the light quantity with the ND filter.
- If **ND** flashed, make sure that the ND FILTER switch is set correctly.
- When recording a bright scene such as under a clear sky with fast shutter speed, image movement may not be smooth. Use the appropriate ND filter to adjust light quantity.

### Hint



- While recording a bright subject, diffraction may occur if you close the aperture further down, resulting in a fuzzy focus (this is a common phenomenon with video cameras). The ND FILTER switch suppresses this phenomenon and gives better recording results.



## Adjusting the color to the natural tone ( WHITE BALANCE)

You can adjust and fix the white balance according to the lighting conditions of recording environment.



You can select A, B, or PRESET for the white balance setting.

A() or B() is the setting that is stored in memory A or B in advance.

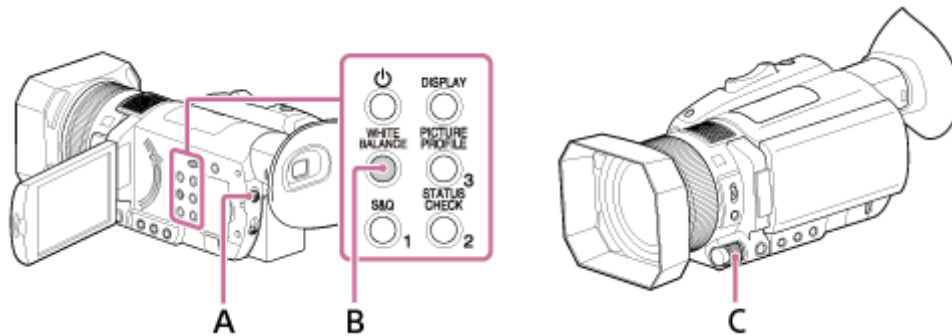
PRESET is the preset setting of [OUTDOOR], [INDOOR], or [MANU WB TEMP] that is selected on [WB PRESET] in the  (CAMERA SET) menu in advance.



- A: AUTO/MANUAL switch
- B: WHITE BALANCE button
- C: Manual dial

- 1 Set the AUTO/MANUAL switch to MANUAL.
- 2 Press the WHITE BALANCE button.
  - Status of camcorder changes from Auto (no indicator is displayed) to Manual and white balance value is highlighted. Either indicator of the white balance value set in [WB PRESET], , and  is displayed.
- 3 Turn the manual dial to select A, B, or PRESET .
  - Setting of A or B :  
Select A or B for recording with the white balance setting stored in memory A or B.
  - Setting of PRESET  
Select the desired setting on  (CAMERA SET) - [WB PRESET].

### About the preset setting

#### OUTDOOR:

- When shooting a night scene, neon lighting, fireworks, etc.
- When shooting a sunrise, sunset, etc.
- Under daylight fluorescent lamp

#### INDOOR:

- Where lighting conditions change, such as at a party place, etc.
- Under video light, such as in a studio, etc.
- Under a sodium or mercury lamp

## MANU WB TEMP:

- You can set a desired color temperature between 2300K and 15000K on  (CAMERA SET) - [WB TEMP SET] (the default setting is 6500K).





## To adjust the white balance automatically

Press the WHITE BALANCE button.

### Note

- When you set the AUTO/MANUAL switch to AUTO, the iris, gain, ISO sensitivity, shutter speed, and white balance is adjusted automatically. You cannot adjust them manually.

### Hint

- If [WB SET] is assigned to the ASSIGN button, the adjusted value is stored by pressing the ASSIGN button when the shooting screen is displayed, instead of performing steps 4 to 7 of “[Storing the adjusted white balance value in memory A or B.](#)”
- You can change this setting directly with  /  /  /  /SET button the on the shooting standby screen (Direct Menu).

---

## Related Topic



- [Storing the adjusted white balance value in memory A or B](#)
- [WB PRESET](#)
- [WB OUTDOOR LEVEL](#)
- [WB TEMP SET](#)
- [Assigning the functions to the ASSIGN buttons](#)
- [Performing shooting adjustment with Direct Menu](#)

## Storing the adjusted white balance value in memory A or B

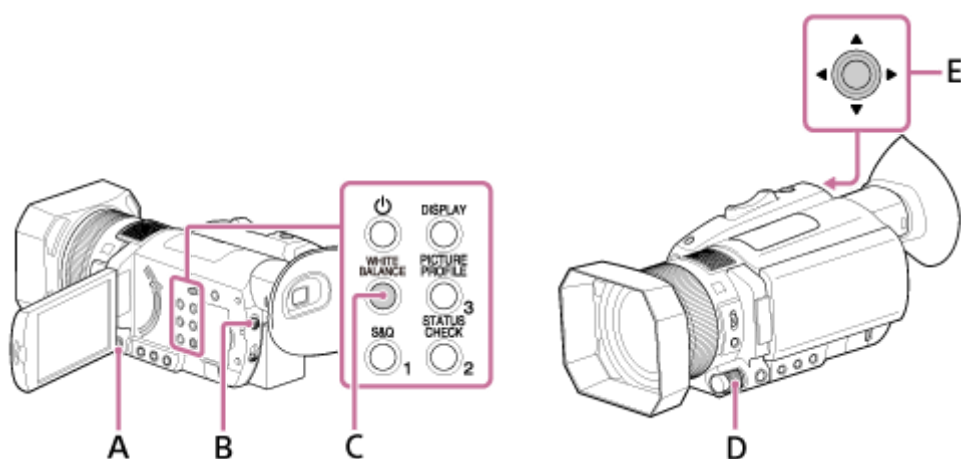
You can store adjusted white balance values in memory A (A) and memory B (B), respectively. You can shoot with the white balance setting that is set in advance by storing the adjusted white balance value. Unless a white balance is readjusted, values will remain even after the power has been turned off.



- A: MENU button  
B: AUTO/MANUAL switch  
C: WHITE BALANCE button  
D: Manual dial  
E : ▲ / ▼ / ◀ / ▶ / SET button

- 1 Set the AUTO/MANUAL switch to MANUAL.
- 2 Press the WHITE BALANCE button to highlight the white balance value.
- 3 Turn the manual dial to select A(  A) or B(  B).
- 4 Press the MENU button.
- 5 Select  (CAMERA SET) - [WB SET] with ▲ / ▼ / ◀ / ▶ / SET button.
- 6 Frame a white object such as a piece of paper that fills the screen under the same lighting conditions as your subject.
- 7 Press the SET button.
  - The adjusted value is stored in A or B.
  - The stored color temperature appears for about 3 seconds.

### Note

- If you cannot adjust the white balance during selecting A or B, A or B turns to slow flashing. Adjust the subject appropriately and set the shutter speed to auto or around 1/60 (when [60i] is selected)/1/50 (when [50i] is selected), then try adjusting the white

balance again.

---

---

#### Related Topic

- [Adjusting the color to the natural tone \(WHITE BALANCE\)](#)

4-725-312-11(2) Copyright 2017 Sony Corporation

## Recording audio with the internal microphone

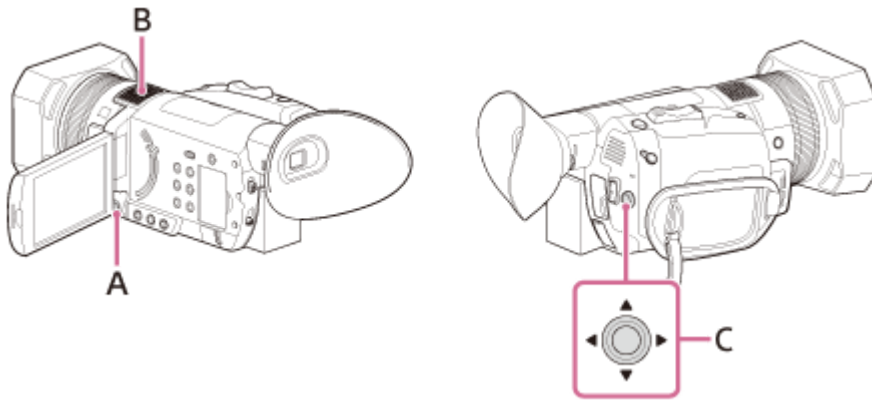

You can record audio in stereo with the camcorder's internal microphone.



- A: MENU button  
B: Internal microphone  
C: ▲/▼/◀/▶/SET button

- 1 Press the MENU button.
- 2 Select  (AUDIO SET) - [MIC SELECT] - [INT MIC] with the ▲/▼/◀/▶/SET button.

### Hint

- To reduce wind noise, set MENU button -  (AUDIO SET) - [INT MIC WIND] - [ON].
- The recording level of audio is adjusted automatically. To adjust manually, select MENU -  (AUDIO SET) - [AUDIO REC LEVEL] - [REC LEVEL MODE] - [MANUAL REC LEVEL].

### Related Topic

- [MIC SELECT](#)
- [INT MIC WIND](#)
- [AUDIO REC LEVEL](#)

## Recording audio with a Multi interface shoe compatible microphone (sold separately)

You can record audio in stereo with a Multi interface shoe compatible microphone.

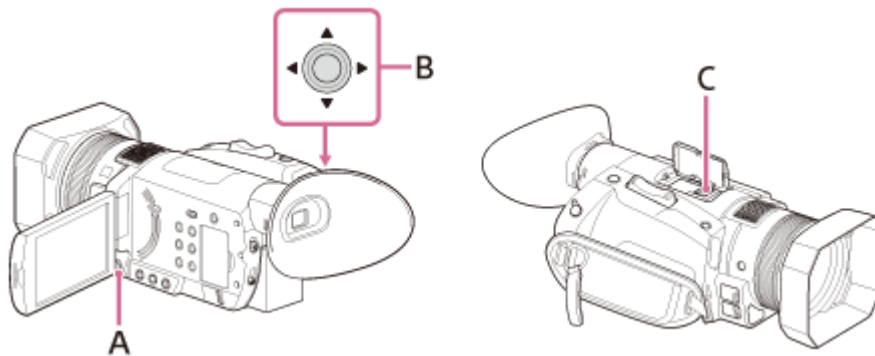

A: MENU button

B: ▲ / ▼ / ◀ / ▶ / SET button

C: Multi interface shoe

- 1 Connect the Multi interface shoe compatible microphone (sold separately) to the Multi interface shoe.
  - For details about connection, refer to the instruction manuals of the Multi interface shoe compatible microphone.
- 2 Press the MENU button.
- 3 Select  (AUDIO SET) - [MIC SELECT] - [MI SHOE MIC] with ▲ / ▼ / ◀ / ▶ / SET button.

### Hint

- The recording level of audio is adjusted automatically. You cannot adjust the recording level of audio manually when using a Multi interface shoe compatible microphone.

### Related Topic

- [MIC SELECT](#)

## Recording audio with an external microphone (sold separately)

You can record audio in stereo with an external microphone (sold separately).

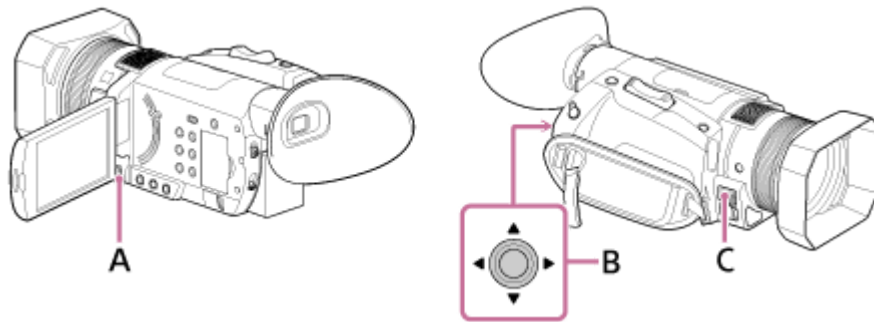

- A: MENU button  
B: ▲ / ▼ / ◀ / ▶ / SET button  
C: MIC jack (PLUG IN POWER)

- 1 Connect the external microphone (sold separately) to the MIC jack (PLUG IN POWER).
  - For details about connection, refer to the instruction manuals of the external microphone.
- 2 Press the MENU button.
- 3 Select  (AUDIO SET) - [MIC SELECT] - [STEREO MINI MIC] with the ▲ / ▼ / ◀ / ▶ / SET button.

### Hint

- The recording level of audio is adjusted automatically. To adjust manually, set the MENU button -  (AUDIO SET) - [AUDIO REC LEVEL] - [REC LEVEL MODE] - [MANUAL REC LEVEL].

### Related Topic

- [MIC SELECT](#)
- [AUDIO REC LEVEL](#)

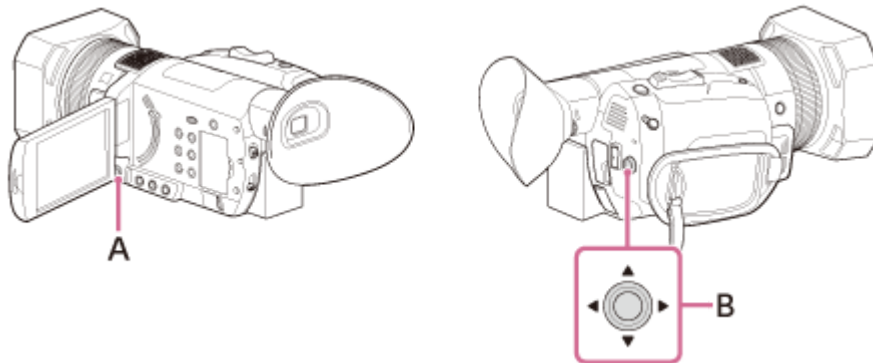

## Shooting in dark conditions ( NIGHTSHOT)

You can shoot scenes under very dark conditions by emitting infrared light.



A: MENU button

B: ▲/▼/◀/▶/SET button

- 1 Press the MENU button.
- 2 Select  (CAMERA SET) - [NIGHTSHOT] - [ON] with ▲/▼/◀/▶/SET button.
  -  appears.

### Note

- NIGHTSHOT is available only when the AUTO/MANUAL switch is set to AUTO.
- NIGHTSHOT uses infrared light. Make sure not to cover NIGHTSHOT light emitter with your fingers, etc.
- Remove the lens hood so that they do not block the NIGHTSHOT light emitter.
- The light is effective up to a distance of approximately 3 meters.
- Do not use NIGHTSHOT in bright conditions. Doing so may damage the camcorder.

### Hint

- You can assign this function to an ASSIGN button.

### Related Topic

- [Parts and controls \(left front side/front\)](#)
- [NIGHTSHOT](#)
- [NIGHTSHOT LIGHT](#)
- [Assigning the functions to the ASSIGN buttons](#)





## Shooting with the picture quality that is set in advance ( PICTURE PROFILE)

You can change the setting of coloring or gradation of images to be recorded.

For details about each setting of [PICTURE PROFILE], refer to the following URL. Note that setting contents or setting methods may differ depending on the camcorder you are using.

<http://helpguide.sony.net/di/pp/v1/en/index.html>

You can make adjustments for the time of day, weather conditions, or just personal preference. Connect the camcorder to a TV or monitor, and adjust the picture quality while observing the picture on the TV or monitor screen.

Picture quality settings for different recording conditions have been stored in **PP1** through **PP10** (picture profile1 through 10) as default settings. You can select the desired picture profile and perform shooting with the settings of the selected picture profile.

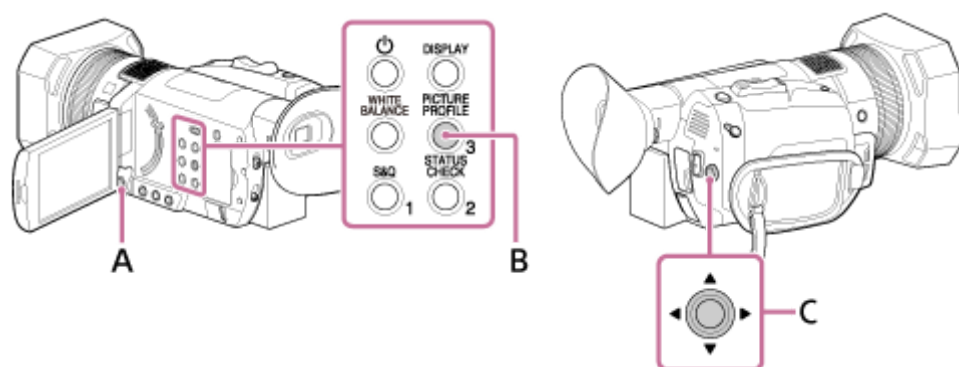

A: MENU button

B: PICTURE PROFILE button (assigned to the ASSIGN3 button by default)

C: ▲ / ▼ / ◀ / ▶ / SET button

- 1 Press the PICTURE PROFILE button during standby .
- 2 Select the picture profile number with the ▲ / ▼ / ◀ / ▶ / SET button.
  - The picture profiles are set as follows in advance.
    - OFF:  
Does not use the picture profile.
    - PP1:  
Example settings of a color tone with [STANDARD] gamma
    - PP2:  
Example settings with color tone like an interchangeable-lens still camera movie with [STILL] gamma
    - PP3:  
Example settings of natural color tone with [ITU709] gamma
    - PP4:  
Example settings of a color tone with [ITU709 MATRIX] color mode
    - PP5:  
Example settings of a color tone with [CINE1] gamma
    - PP6:  
Example settings of a color tone with [CINE2] gamma
    - PP7:  
Recommended setting when shooting with [S-LOG2] gamma and [S-GAMUT] color mode
    - PP8:  
Recommended setting when shooting with [S-LOG3] gamma and [S-GAMUT3.CINE] color mode
    - PP9:  
Recommended setting when shooting with [S-LOG3] gamma and [S-GAMUT3] color mode
    - PP10:

## Example settings for recording HDR movies with [HLG2] gamma

- 3 Select [OK] with the ▲ / ▼ / ◀ / ▶ /SET button.
  - You can record movies with selected picture profile setting.

### To cancel the picture profile recording

Select [OFF] in step 2.

### HDR movie recording

The camcorder can record HDR movies if you select HLG, HLG1, HLG2, or HLG3 gamma in PICTURE PROFILE. As an example setting of HDR recording is preset on PP10 in PICTURE PROFILE, you can view the movie with wider brightness range than ever if it is played back on a TV supported Hybrid Log-Gamma (HLG). This makes it possible to record images with blocked-up shadows and blown-out highlights, which have been unable to reproduce faithfully in the past. HLG is a system of high dynamic range TV defined in the international standard Recommendation ITU-R BT.2100.

#### Note

- To view images recorded with HDR on a TV, connect the camcorder to an HDR (HLG) compatible TV manufactured by Sony with a USB cable.  
When you connect a TV with an HDMI cable, you need to change the image quality setting of the TV manually in order to display images properly. Set the image quality of the TV as follows.
  - Gamma: Setting compatible with HLG
  - Color mode: Setting compatible with BT.2020 or 709

---

### Related Topic

- [Changing the picture profile](#)
- [Copying the picture profile setting to another picture profile number](#)
- [Resetting the picture profile settings](#)
- [Assigning the functions to the ASSIGN buttons](#)

## Changing the picture profile

You can change the settings stored in **PP1** through **PP10** .

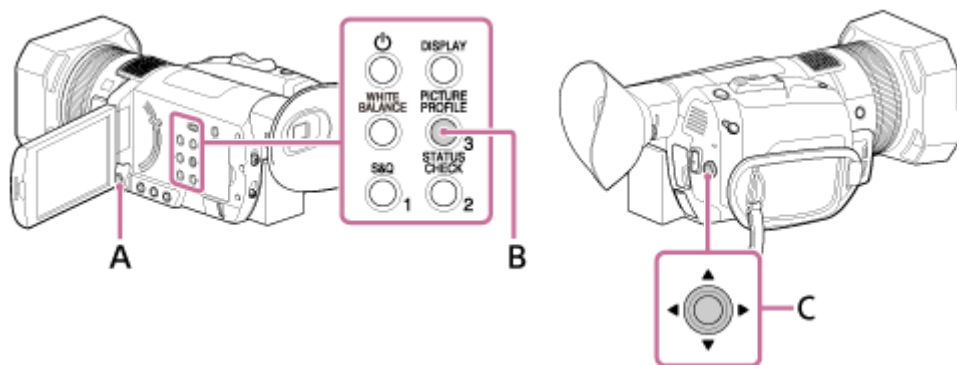

A: MENU button

B: PICTURE PROFILE button (assigned to the ASSIGN3 button by default)

C: ▲/▼/◀/▶/SET button

- 1 Press the PICTURE PROFILE button.
- 2 Select the picture profile number that you want to change with ▲/▼/◀/▶/SET button.
- 3 Select [SETTING] with ▲/▼/◀/▶/SET button.
- 4 Select the item that you want to adjust with ▲/▼/◀/▶/SET button.
- 5 Adjust the picture quality with ▲/▼/◀/▶/SET button.
- 6 Repeat steps 4 and 5 to adjust other items.
- 7 Select [↶ RETURN] with ▲/▼/◀/▶/SET button.
- 8 Select [OK] with ▲/▼/◀/▶/SET button.
  - The picture profile indicator appears.

### Setting items of the picture profile

You can change the following items.

#### BLACK LEVEL:

Sets the black level.

- -15 to +15

## GAMMA :

Select a gamma curve.

- STANDARD: Standard gamma curve for movies
- STILL: Gamma curve like an interchangeable-lens still camera movie.
- CINE1: Makes soft color images by decreasing dark area contrast and sharpening bright area tone changes (equivalent to HG4609G33 ).
- CINE2: Almost the same effect as [CINE1]; select this if you want to treat the image in a range within 100% of video signal when editing, etc. (equivalent to HG4600G30).
- CINE3: Increases contrast between bright areas and dark areas more than those of [CINE1] and [CINE2], sharpening dark area tone changes.
- CINE4: Increases dark area contrast more than that of [CINE3]. The dark area contrast is weaker and the bright area contrast is stronger than that of [STANDARD].
- ITU709: Gamma curve that corresponds to ITU-709. Gain in low intensity area: 4.5
- ITU709(800%): Gamma curve for checking scenes when shooting using [S-LOG2] or [S-LOG3].
- S-LOG2: [S-LOG2] gamma curve. This setting presumes editing in post-production after shooting.
- S-LOG3: [S-LOG3] gamma curve. Gamma curve with characteristics similar to film, and which presumes editing in post-production after shooting.
- HLG: Gamma curve for HDR recording that corresponds to ITU-R BT.2100.
- HLG1: Gamma curve for HDR recording. In this setting, reduction of the noise level takes priority, but dynamic range for shooting is narrower than that of [HLG2] or [HLG3].
- HLG2: Gamma curve for HDR recording. This setting considers the balance between dynamic range and noise.
- HLG3: Gamma curve for HDR recording. Dynamic range is wider than that of [HLG2] but the noise level is higher. [HLG1], [HLG2], or [HLG3] is gamma curve with same characteristics whose balance between dynamic range and noise are different. Maximum video output level value of each differs as follows:  
[HLG1]: approx. 87%, [HLG2]: approx. 95%, [HLG3]: approx. 100%

## BLACK GAMMA:

Corrects gamma in low intensity area.

When [HLG], [HLG1], [HLG2] or [HLG3] is selected for [GAMMA], [BLACK GAMMA] is disabled.

- RANGE: Select a correcting range.  
HIGH/MIDDLE/LOW
- LEVEL: Select a correcting level.  
-7 (maximum black compression) to +7 (maximum black stretch)

## KNEE:

Sets the knee point and slope for video signal compression to prevent over-exposure by limiting signals in high intensity areas of the subject to the dynamic range of the camcorder.

When [CINE1], [CINE2], [CINE3], [CINE4], [STILL], [ITU709(800%)], [S-LOG2], [S-LOG3], [HLG], [HLG1], [HLG2], or [HLG3] is selected in [GAMMA], [KNEE] is disabled if [MODE] is set to [AUTO]. To use functions in [KNEE], set [MODE] to [MANUAL].

- MODE: Select automatic or manual mode.
  - AUTO: Sets the knee point and slope automatically.
  - MANUAL: Sets the knee point and slope manually.
- AUTO SET: Set the maximum point and sensitivity in [AUTO] mode.
  - MAX POINT: Sets the maximum value of the knee point.  
90.0% to 100.0%
  - SENSITIVITY: Sets the sensitivity.  
HIGH/SENSITIVITY/LOW
- MANUAL SET : Set the knee point and slope in [MANUAL] mode.
  - POINT: Set the knee point.  
75.0% to 105.0%

- SLOPE: Sets the knee slope.  
–5 (gentle) to +5 (steep)  
[KNEE] is set off when you set to +5.

#### COLOR MODE:

Sets type and level of colors.

When [HLG], [HLG1], [HLG2] or [HLG3] is selected in [GAMMA], only [BT.2020] and [709] can be selected for [COLOR MODE].

When [BT.2020] is selected, the color bar is not output properly.

- STANDARD: Suitable color tone when [GAMMA] is set to [STANDARD].
- STILL: Suitable color tone when [GAMMA] is set to [STILL].
- CINEMA: Film camera image-like color tone good with [GAMMA] set to [CINE1].
- PRO: Natural color tone when [GAMMA] is set to [ITU709].
- ITU709 MATRIX: Color tone which is faithful to the ITU-709 standard.
- B/W: Sets the saturation to 0 and records in black and white.
- S-GAMUT/3200K, S-GAMUT/4300K, S-GAMUT/5500K: Setting that presumes editing in post-production after recording when [GAMMA] is set to [S-LOG2].
- S-GAMUT3.CINE/3200K, S-GAMUT3.CINE/4300K, S-GAMUT3.CINE/5500K: Setting that presumes editing in post-production after recording when [GAMMA] is set to [S-LOG3]. Supports recording in a color gamut for easy adjustment to digital cinema color gamut.
- S-GAMUT3/3200K, S-GAMUT3/4300K, S-GAMUT3/5500K: Setting that presumes editing in post-production after recording when [GAMMA] is set to [S-LOG3]. Supports recording with wide color gamut.
- BT.2020: Standard color tone when [HLG], [HLG1], [HLG2] or [HLG3] is selected for [GAMMA].
- 709: Color tone when [HLG], [HLG1], [HLG2] or [HLG3] is selected for [GAMMA], and record movies with the color of High Definition TV system (BT.709).

#### SATURATION:

Sets the color level.

- –32 (light) to +32 (dark)

#### COLOR PHASE:

Set the color phase.

- –7 (greenish) to +7 (reddish)

#### COLOR DEPTH:

Sets the color depth for each color phase.

This function is more effective for chromatic colors and ineffective for achromatic colors.

The color looks deeper as you increase the setting value to more positive side, and lighter as you decrease the value to more negative side.

This function is effective even if you set [SATURATION] to [-32] (black and white).

- R: –7 (light red) to +7 (deep red)
- G: –7 (light green) to +7 (deep green)
- B: –7 (light blue) to +7 (deep blue)
- C: –7 (light cyan) to +7 (deep cyan)
- M: –7 (light magenta) to +7 (deep magenta)
- Y: –7 (light yellow) to +7 (deep yellow)

#### COLOR CORRECTION:

Sets the color correction.

- TYPE: Select color correction type.
  - OFF: Does not correct colors.

- COLOR REVISION: Corrects colors stored in memory.  
Colors not stored in memory (displayed in black and white when [COLOR EXTRACT] is set) is not corrected.
- COLOR EXTRACT: Displays areas in colors that are stored in the memory. The other areas are displayed in black and white. You can use this function to add effects on your movies or to confirm the colors to be stored in the memory.
- MEMORY SELECTION: Select a memory to be effective.
  - 1: Sets Memory 1 to be effective.
  - 2: Sets Memory 2 to be effective.
  - 1&2: Sets both Memory 1 and 2 to be effective.
- MEMORY1 COLOR: Sets colors stored in Memory 1.
  - PHASE: Sets color phase.  
0 (purple) - 8 (red) - 16 (yellow) - 24 (green) - 31 (blue)
  - PHASE RANGE: Sets color phase range.  
0 (no color selection), 1 (narrow: to select only a single color) to 31 (wide: to select multiple colors in similar color phase)
  - SATURATION: Sets saturation.  
0 (to select from light colors to dark colors) to 31 (to select dark color)
  - ONE PUSH SET: Automatically sets [PHASE] for a subject at the center of the marker.  
[SATURATION] is set to 0.
- MEMORY1 REVISION: Corrects colors in Memory 1.
  - PHASE: Corrects the phase of the color in Memory 1.  
-15 to +15 (0 for no correction.)
  - SATURATION: Corrects the saturation of the color in Memory 1.  
-15 to +15 (0 for no correction.)
- MEMORY2 COLOR: Sets colors stored in Memory 2.
  - PHASE: Sets color phase.  
0 (purple) - 8 (red) - 16 (yellow) - 24 (green) - 31 (blue)
  - PHASE RANGE: Sets color phase range.  
0 (no color selection), 1 (narrow: to select only a single color) to 31 (wide: to select multiple colors in similar color phase)
  - SATURATION: Sets saturation.  
0 (to select from light colors to dark colors) to 31 (to select dark color)
  - ONE PUSH SET: Automatically sets [PHASE] for a subject at the center of the marker.  
[SATURATION] is set to 0.
- MEMORY2 REVISION: Corrects colors in Memory 2.
  - PHASE: Corrects the phase of the color in Memory 2.  
-15 to +15 (0 for no correction.)
  - SATURATION: Corrects the saturation of the color in Memory 2.  
-15 to +15 (0 for no correction.)

#### WB SHIFT:

Sets items for the white balance shift.

Items you can adjust differ depending on the filter type.

- FILTER TYPE: Select a color filter type for the white balance shift.
  - LB-CC: Film type (color conversion and correction)
  - R-B: Video type (correction of R and B levels)
- LB[COLOR TEMP]: Sets a color temperature offset value.  
-9 (bluish) to +9 (reddish)
- CC[MG/GR]: Sets a color correct offset value.  
-9 (greenish) to +9 (magentish)

- R GAIN: Sets an R level.  
-9 (low R level) to +9 (high R level)
- B GAIN: Sets a B level.  
-9 (low B level) to +9 (high B level)

#### DETAIL:

Sets items for the detail.

- LEVEL: Sets the level of [DETAIL].  
-7 to +7
- MANUAL SET :
  - ON/OFF: Turns on and off the manual adjustment of [DETAIL].  
When setting to [ON], you can perform the manual adjustment of [DETAIL] (automatic optimization is not performed).
  - V/H BALANCE: Sets the vertical (V) and horizontal (H) balance of detail.  
-2 (vertical (V) side) to +2 (horizontal (H) side)
  - B/W BALANCE : Selects the balance of the lower detail (B) and the upper detail (W).  
TYPE1 (lower (B) side) to TYPE5 (upper (W) side)
  - LIMIT: Sets the limit level of [DETAIL].  
0 (Low limit level: likely to be limited) to 7 (High limit level: not likely to be limited)
  - CRISPENING: Sets the crispening level.  
0 (shallow crispening level) to 7 (deep crispening level)
  - HI-LIGHT DETAIL: Sets the detail level in the high intensity areas.  
0 to 4

#### COPY:

Copies the settings of the picture profile to another picture profile number.

#### RESET:

Resets the picture profile to the default setting.

#### Hint

- Setting both memory1 and memory2 to the same setting doubles the color correction effect.
- The settings of [COLOR CORRECTION] will be retained even if the power is turned off. However, if you want to correct colors that may change according to time of the day, weather, location, etc., it is recommended that you set [COLOR CORRECTION] again prior to shooting.
- If you change the white balance value or the settings of [WB SHIFT], [SATURATION], or [COLOR PHASE] of the picture profile, the settings of [PHASE RANGE] and [PHASE] of the selected memory will change. When you change the white balance value or the settings of the above picture profile items after you have set [PHASE RANGE] and [PHASE], check the settings of [COLOR CORRECTION] prior to shooting.
- During the automatic white balance adjustment, the white balance value automatically varies according to the lighting conditions of your recording environment. The manual white balance adjustment is recommended when you use [COLOR CORRECTION].

#### Related Topic

- [Shooting with the picture quality that is set in advance \(PICTURE PROFILE\)](#)
- [Copying the picture profile setting to another picture profile number](#)
- [Resetting the picture profile settings](#)
- [Assigning the functions to the ASSIGN buttons](#)



## Copying the picture profile setting to another picture profile number

You can copy the picture profile setting to another picture profile number. This is useful for setting similar settings to the camcorder.

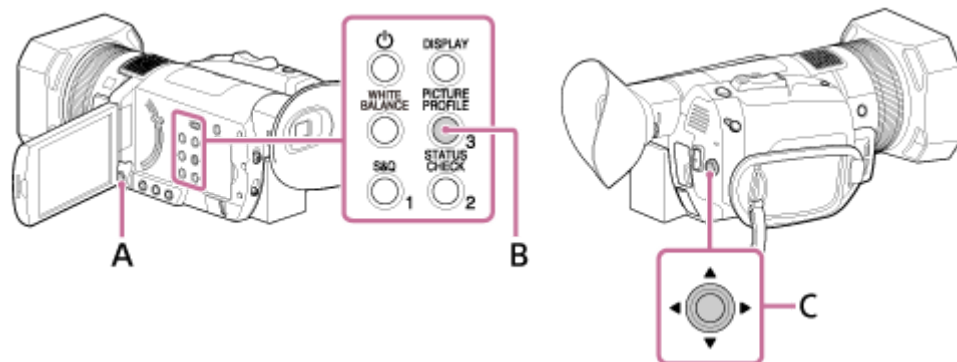

A: MENU button

B: PICTURE PROFILE button (assigned to the ASSIGN3 button by default)

C: ▲/▼/◀/▶/SET button

- 1 Press the PICTURE PROFILE button.
- 2 Select the picture profile number that you want to copy from with the ▲/▼/◀/▶/SET button.
- 3 Select [SETTING] - [COPY] with the ▲/▼/◀/▶/SET button.
- 4 Select the picture profile number that you want to copy with the ▲/▼/◀/▶/SET button.
- 5 Select [YES] - [↶ RETURN] - [OK] with the ▲/▼/◀/▶/SET button.

### Related Topic

- [Shooting with the picture quality that is set in advance \(PICTURE PROFILE\)](#)
- [Changing the picture profile](#)
- [Resetting the picture profile settings](#)
- [Assigning the functions to the ASSIGN buttons](#)

## Resetting the picture profile settings

You can reset the picture profile settings by each picture profile number. You cannot reset all picture profile settings at once.

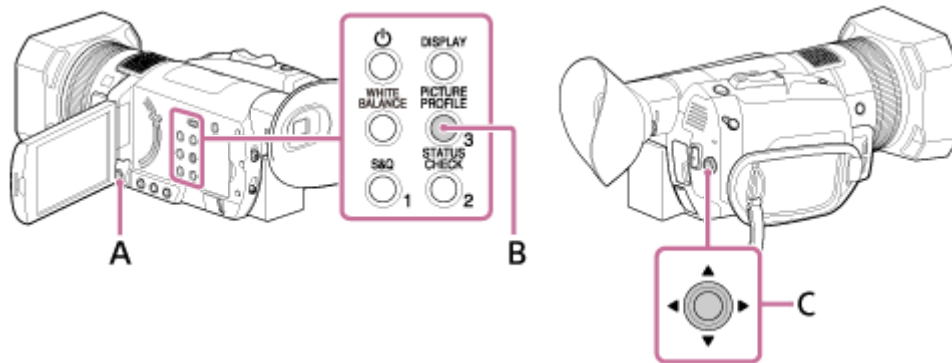

A: MENU button

B: PICTURE PROFILE button (assigned to the ASSIGN3 button by default)

C: ▲/▼/◀/▶/SET button

- 1 Press the PICTURE PROFILE button.
- 2 Select the picture profile number that you want to reset with ▲/▼/◀/▶/SET button.
- 3 Select [SETTING] - [RESET] - [YES] - [↩️ RETURN] - [OK] with the ▲/▼/◀/▶/SET button.

### Related Topic

- [Shooting with the picture quality that is set in advance \(PICTURE PROFILE\)](#)
- [Changing the picture profile](#)
- [Copying the picture profile setting to another picture profile number](#)
- [Adjusting the color to the natural tone \(WHITE BALANCE\)](#)
- [Assigning the functions to the ASSIGN buttons](#)

## Recording with Slow & Quick Motion

By shooting with a frame rate that is different from the playback frame rate, you can record images to be played back as slow motion or quick motion images. The images recorded with Slow & Quick Motion will appear smoother than slow or fast-forward playback of images recorded at normal speed (XAVC S 4K and XAVC S HD only).

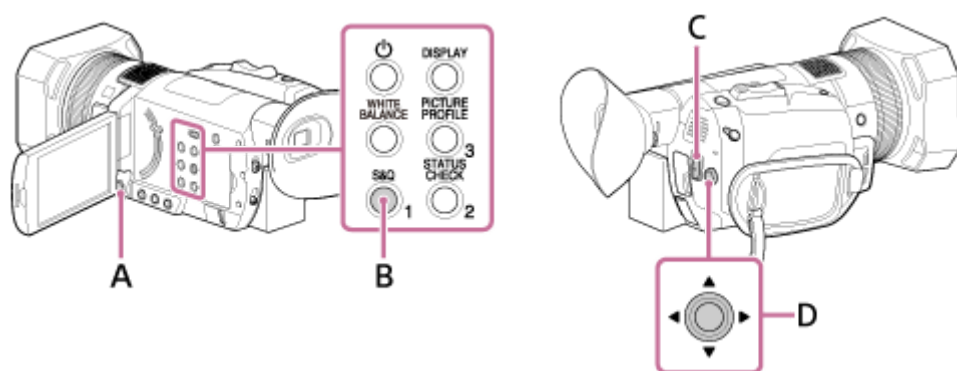

- A: MENU button  
B: S&Q button  
C: START/STOP button  
D: ▲/▼/◀/▶/SET button

### Preparation for the Slow & Quick Motion recording

Set the recording format and frame rate on MENU button - (CAMERA SET) - [SLOW & QUICK] - [S&Q MOTION].

### To record with Slow & Quick Motion

- 1 Press the S&Q button to display [ S&Q MOTION].
  - The camcorder is in the Slow & Quick Motion recording mode.
  - You can set the camcorder to the Slow & Quick Motion recording mode by selecting (CAMERA SET) - [SLOW & QUICK] - [S&Q MOTION] - [EXECUTE].
- 2 Press the START/STOP button.
  - The Slow & Quick Motion recording starts.

### To stop the Slow & Quick Motion recording

Press the START/STOP button again.

### To change the frame rate setting

Hold the S&Q button down for about 1 second and change the value with the ▲/▼/◀/▶/SET button, then press the ▲/▼/◀/▶/SET button to enter.

### To cancel the Slow & Quick Motion recording

Press the S&Q button or MENU button.

#### Note

- The supported memory cards vary depending on the file format.
- When recording with Quick Motion, the camcorder may continue recording for some time (approximately 30 seconds at most) after you press the START/STOP button to stop recording. Do not operate the camcorder while the [REC] indicator is flashing on the LCD monitor. Wait until it turns to [STBY].
- After you press the START/STOP button to stop recording, the camcorder continues recording until it completes writing of the minimum unit of data (0.5 seconds of replay time). When recording with slow frame rate, it may take time to stop recording after pressing the START/STOP button.
- The frame rate setting cannot be changed while Slow & Quick Motion recording. To change the setting, stop recording.
- The time code is recorded in [REC RUN] mode.
- The Slow & Quick Motion recording mode is canceled automatically when the camcorder is turned off, but the frame rate setting is retained.
- You cannot record audio during the Slow & Quick Motion recording.
- You cannot perform Simultaneous recording during the Slow & Quick Motion recording.
- [S&Q MOTION] is disabled when [FILE FORMAT] is set to [AVCHD].
- [S&Q MOTION] is disabled when the AUTO/MANUAL switch is set to AUTO.

---

#### Related Topic

- [Types of memory card you can use with your camcorder](#)
- [Recording movies on both the memory card A and B \(Simultaneous recording\)](#)
- [SLOW & QUICK \(S&Q MOTION\)](#)
- [TC RUN](#)
- [S&Q BUTTON SETTING](#)

## Recording with Super Slow Motion

By recording with a frame rate much higher than the playback frame rate, you can record images to be played back as super slow motion images. Images recorded with the Super Slow Motion function will appear smoother than slow playback of images recorded at normal speed (XAVC S HD only).

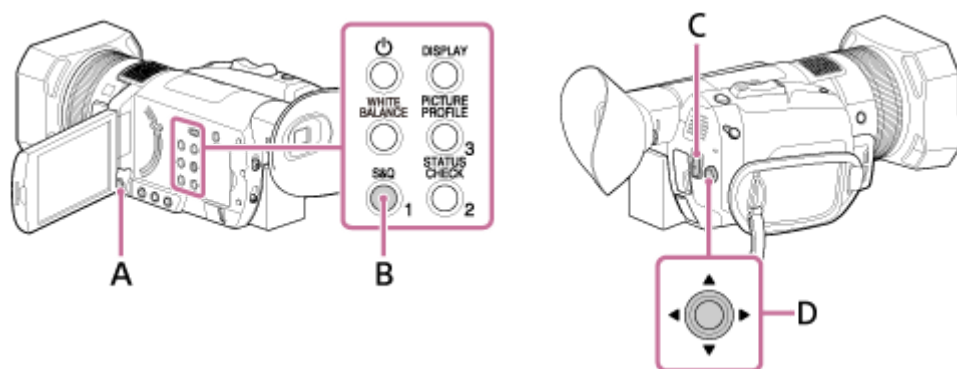

- A: MENU button
- B: S&Q button
- C: START/STOP button
- D : ▲ / ▼ / ◀ / ▶ / SET button

### Preparation for the Super Slow Motion recording

Set the recording format, frame rate, and recording timing on MENU button - (CAMERA SET) - [SLOW & QUICK] - [SUPER SLOW MOTION].

### To record with Super Slow Motion

- 1 Press the S&Q button repeatedly to display [ SUPER SLOW MOTION ].
  - The camcorder is in the Super Slow Motion recording mode.
  - You can set the camcorder to the Super Slow Motion recording mode by selecting (CAMERA SET) - [SLOW & QUICK] - [SUPER SLOW MOTION] - [EXECUTE].
- 2 Press the START/STOP button.
  - The Super Slow Motion recording starts.

### To decide the recording time manually

If [REC TIMING] is set to [START TRIGGER], you can stop recording at any time by pressing START/STOP button.

### If you missed a scene you wished to record

To stop recording, select [Cancel] on the recording screen.

Recording stops, and the contents you have shot are not saved. This is convenient when you wish to start recording again soon.

### To change the frame rate setting

Hold the S&Q button down for about 1 second and change the value with ▲ / ▼ / ◀ / ▶ /SET button, then press ▲ / ▼ / ◀ / ▶ /SET button to enter.

## To cancel the Super Slow Motion recording

Press the S&Q button or MENU button during standby.

### Note

- The supported memory cards vary depending on the file format.
- When recording with Super Slow Motion recording, the camcorder may continue recording for some time (approximately 3 minutes at most) after you press the START/STOP button to stop recording. Do not operate your camcorder while the [REC] indicator is flashing on the LCD monitor. Wait until it turns to [STBY].
- After you press the START/STOP button to stop recording, the camcorder continues recording until it completes writing of the minimum unit of data (0.5 seconds of replay time).
- The Super Slow Motion recording is available only when full auto mode is off. Note that iris, gain, focus, and shutter speed are fixed to manual.
- When [960fps] ([1000fps]) is selected in [FRAME RATE], the image to be displayed and recorded shifts approximately 1.35 times toward the telephoto side.
- When [480fps], [960fps] ([500fps]), [1000fps] is selected in [FRAME RATE], the image quality is deteriorated compared with the image with normal recording.
- If you adjust the gain or shutter speed, or change the white balance, the image on the LCD screen changes. However, the camera setting at the time the recording ends is reflected in the recorded image.
- To change the frame rate setting, first stop recording.
- The time code is recorded in [REC RUN] mode.
- The Super Slow Motion recording mode is canceled automatically when the camcorder is turned off, but the frame rate setting is retained.
- Flicker adjustment is not available.
- You cannot record audio during the Super Slow Motion recording.
- Auto focus function is not available.
- You cannot select a shutter speed value slower than the frame rate.
- [SUPER SLOW MOTION] is disabled when [FILE FORMAT] is set to [XAVC S 4K] or [AVCHD].
- [SUPER SLOW MOTION] is disabled when the AUTO/MANUAL switch is set to AUTO.

---

### Related Topic

- [Types of memory card you can use with your camcorder](#)
- [SLOW & QUICK \(SUPER SLOW MOTION\)](#)
- [TC RUN](#)
- [S&Q BUTTON SETTING](#)

## Performing shooting adjustment with Direct Menu

You can change the settings for shooting that is displayed on the LCD monitor directly with the ▲ / ▼ / ◀ / ▶ / SET button. The following settings can be changed using Direct Menu.

- Focus value
- AE shift level value
- Iris value
- ISO sensitivity/gain
- Shutter speed value
- White balance value

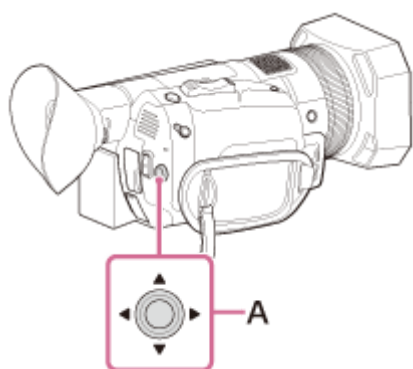

A : ▲ / ▼ / ◀ / ▶ / SET button

1 Press the ASSIGN button to which the Direct Menu function is assigned.

- The camcorder is in Direct Menu mode and a cursor (underline) is displayed for items along the bottom of the LCD screen.
  - Orange cursor indicates the selected item.
  - White cursor indicates selectable items.

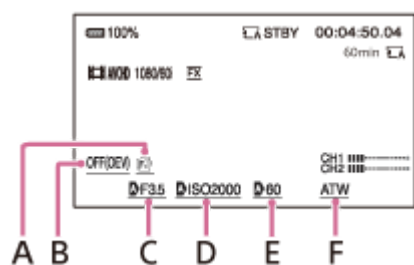

- A: Focus value
- B: AE shift level value
- C: Iris value
- D: ISO sensitivity/gain
- E: Shutter speed value
- F: White balance value

- For details about assigning the function to the ASSIGN button, see [“Assigning the functions to the ASSIGN buttons.”](#)

2 Move the ▲ / ▼ / ◀ / ▶ / SET button right and left to move the orange cursor to select the target item that you want to set.

3 When **A** (auto) appears for the item to set, move the ▲/▼/◀/▶/SET button up and down to delete the mark.

4 Press the ▲/▼/◀/▶/SET button to select the setting.

- The set value is highlighted, allowing you to change the value. The following diagram shows an example of changing the shutter speed value.

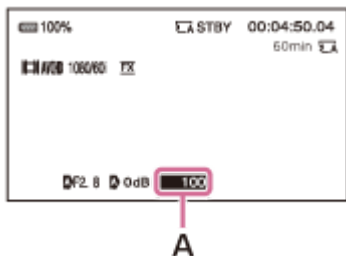

A: Shutter speed value

5 Move the ▲/▼/◀/▶/SET button up and down to display the desired value.

- You can also change the value with the manual dial.

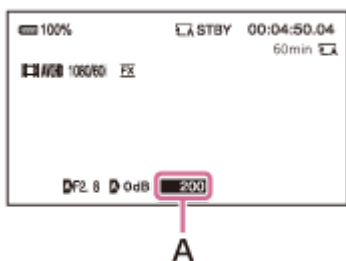

A: Changed shutter speed value

6 To set another item, repeat steps 3 to 5 to shift the orange cursor to the item you want to set by moving the ▲/▼/◀/▶/SET button right or left.

7 When all desired values are displayed, press the ▲/▼/◀/▶/SET button.

- The setting is applied, and the camcorder exits from the Direct Menu.

### Note

- Direct Menu is not available when using the following functions (including operation using operation buttons/ASSIGN buttons).
  - During menu screen
  - During play mode
  - S&Q MOTION
  - SUPER SLOW MOTION
  - FOCUS MAGNIFIER
  - SPOT METER/FOCUS
  - SPOT METER
  - SPOT FOCUS
  - Focus area setting
  - Controlling volume
  - CTRL W/SMARTPHONE
- If an item (such as iris value or focus value) is changed using buttons or switches while Direct Menu is displayed, the Direct Menu may be canceled.



## Hint

- When white balance is set to be adjusted automatically, [ATW] is displayed.
- When focus is set to autofocus, [AF] is displayed.
- You can assign this function to the ASSIGN button.

---

## Related Topic

- [Assigning the functions to the ASSIGN buttons](#)
- [AE SHIFT](#)
- [Adjusting the focus manually](#)
- [Adjusting the iris](#)
- [Adjusting the gain](#)
- [Adjusting the ISO sensitivity](#)
- [Adjusting the shutter speed](#)
- [Adjusting the color to the natural tone \(WHITE BALANCE\)](#)

## Proxy recording

You can record a low bitrate proxy file at the same time as recording the high bitrate original movie file. The proxy file is suitable for data transferring as the size of proxy files is smaller than that of the high bitrate original movie file.

Proxy recording is supported only when [FILE FORMAT] is set to [XAVC S 4K] or [XAVC S HD].

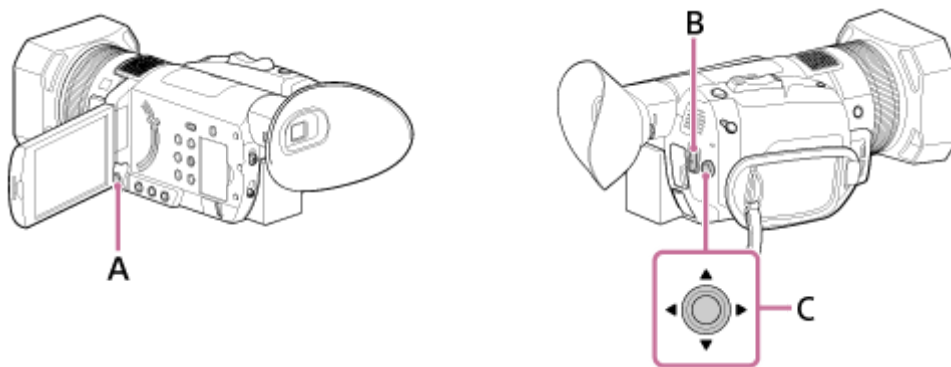

- A: MENU button  
B: START/STOP button  
C : ▲ / ▼ / ◀ / ▶ / SET button

- 1 Press the MENU button.
- 2 Select **⇄** (REC/OUT SET) - [REC SET] - [PROXY REC MODE] - [ON/OFF] - [ON] with the ▲ / ▼ / ◀ / ▶ / SET button.
  - **Px** appears on the shooting screen.
  - You can select the image size for Proxy recording on **⇄** (REC/OUT SET) - [REC SET] - [PROXY REC MODE] - [SIZE].
- 3 Press the START/STOP button to start recording.

### About Proxy recording files

- Proxy files cannot be played on the camcorder. **Px** appears on the thumbnail of the original file.
- A proxy file is also deleted/protected when the corresponding original file is deleted/protected.
- We recommend using an SDXC memory card (UHS-I U3) for Proxy recording.

### Proxy recording supported formats

The image size of the recorded original movie file and recorded proxy file is as follows.

[60i/50i SEL]	Original file		Proxy file	
	[FILE FORMAT]	[REC FORMAT]	Image size: 1,280 × 720	Image size: 640 × 360
60i	XAVC S 4K	3840x2160/30p	1280x720/30p 9Mbps	640x360/30p 3Mbps
		3840x2160/24p	1280x720/24p 9Mbps	640x360/24p 3Mbps
	XAVC S HD	1920x1080/60p	1280x720/60p 9Mbps	640x360/60p 3Mbps

		1920x1080/30p	1280x720/30p 9Mbps	640x360/30p 3Mbps
		1920x1080/24p	1280x720/24p 9Mbps	640x360/24p 3Mbps
50i	XAVC S 4K	3840x2160/25p	1280x720/25p 9Mbps	640x360/25p 3Mbps
	XAVC S HD	1920x1080/50p	1280x720/50p 9Mbps	640x360/50p 3Mbps
		1920x1080/25p	1280x720/25p 9Mbps	640x360/25p 3Mbps

### Note

- The camcorder cannot perform Proxy recording when the number of XAVC S movie files reaches to 600.
- The following function is not available during Proxy recording.
  - S&Q MOTION
  - SUPER SLOW MOTION
  - COLOR BAR
  - DATE REC
  - When [XAVC S HD] is selected for [FILE FORMAT] and 120p/100p is selected in [REC FORMAT].
  - When [SIMULTANEOUS REC] or [RELAY REC] is selected for [SIMUL/RELAY REC] in [REC SET].
  - When [EXTERNAL OUTPUT] is selected for [OUTPUT SELECT] in [VIDEO OUT].

### Related Topic

- [Recording movies](#)
- [COLOR BAR](#)
- [REC SET](#)
- [DATE REC](#)
- [SLOW & QUICK \(S&Q MOTION\)](#)

## Reviewing the most recently recorded scene (LAST SCENE REVIEW )

You can review the most recently recorded scene on the LCD screen. This function is available when it is assigned to the ASSIGN button.

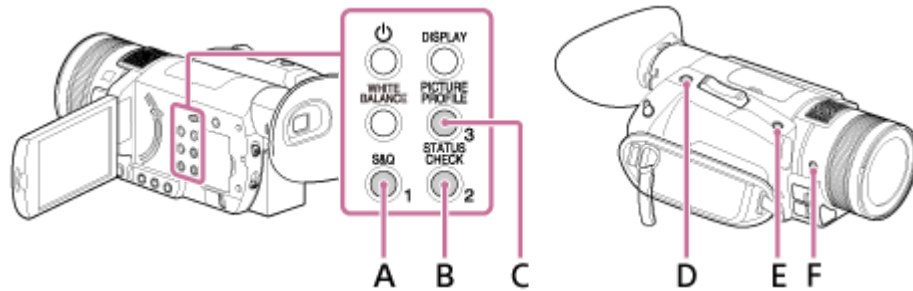

- A: ASSIGN1 button
- B: ASSIGN2 button
- C: ASSIGN3 button
- D: ASSIGN4 button
- E: ASSIGN5 button
- F: ASSIGN6 button

- 1 Assign [LAST SCENE REVIEW ] to one of the ASSIGN1 to 6 buttons.
  - For details about assigning the function to the ASSIGN button, see “[Assigning the functions to the ASSIGN buttons.](#)”
- 2 Right after you stop recording, press the ASSIGN button that you assign the [ LAST SCENE REVIEW].
  - The camcorder plays from the top to the end of the most recently recorded scene, then returns to standby mode.

### To stop reviewing the last scene

Press the ASSIGN button that you assign the [LAST SCENE REVIEW] during playback.  
Reviewing is canceled and the camcorder returns to standby mode.

**Note**

- If you edit the movie or remove the memory card after you stop recording, the Last Scene Review function may not work correctly.
- The Last Scene Review function is not available during the [SUPER SLOW MOTION] recording.

### Related Topic

- [Assigning the functions to the ASSIGN buttons](#)

## Assigning the functions to the ASSIGN buttons

You can assign the desired function to one of the ASSIGN 1 to 6 buttons.

See “[Setting up menu items](#)” on the function of each item.

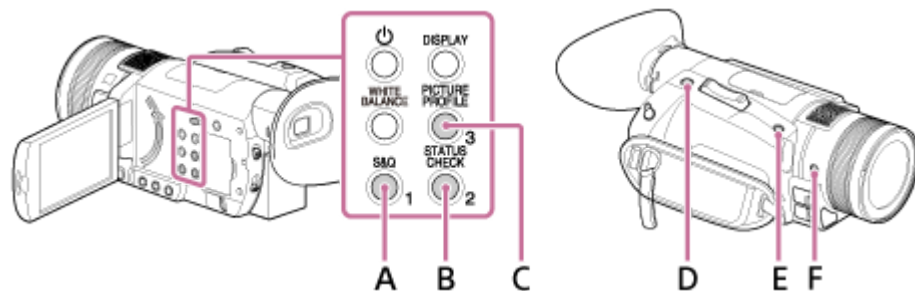



- A: ASSIGN1 button
- B: ASSIGN2 button
- C: ASSIGN3 button
- D: ASSIGN4 button
- E: ASSIGN5 button
- F: ASSIGN6 button

### Default function of each ASSIGN button

- ASSIGN1: S&Q MOTION
- ASSIGN2: STATUS CHECK
- ASSIGN3: PICTURE PROFILE
- ASSIGN4: FOCUS MAGNIFIER
- ASSIGN5: IRIS PUSH AUTO
- ASSIGN6: — (no function)

### Functions you can assign to the ASSIGN buttons

- — (no function)
- LOW LUX
- FOCUS MAGNIFIER
- LAST SCENE REVIEW
- WHITE BALANCE
- WB PRESET
- WB SET
- AE SHIFT
- D. EXTENDER
- STEADYSHOT
- FOCUS AREA
- FOCUS POSITION
- AF DRIVE SPEED
- AF TRACKING DEPTH
- AF SUBJ. SWITCH. SENS.
- FACE DETECTION
- S&Q MOTION
- AUTO MODE SET
- SCENE SELECTION SET
- NIGHTSHOT
- IRIS PUSH AUTO
- SPOT METER/FOCUS
- SPOT METER

- SPOT FOCUS
- COLOR BAR
- DIRECT
- MENU
- PICTURE PROFILE
- VOLUME
- HISTOGRAM
- ZEBRA
- PEAKING
- PHASE AF FRAMES
- MARKER
- CAMERA DATA DISPLAY
- AUDIO LEVEL DISPLAY
- DATA CODE
- GAMMA DISP ASSIST
- TC/UB DISPLAY
- SMARTPHONE CONNECT
- STATUS CHECK
- REC LAMP
- THUMBNAIL
-  /  SHOOTING MODE

To assign the functions to the ASSIGN buttons

1 Press the MENU button.

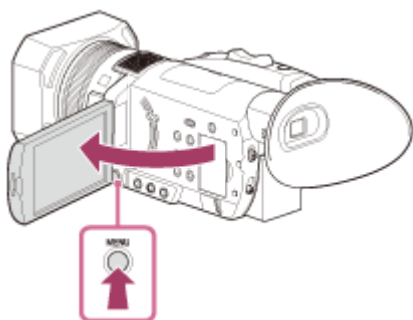

2 Select  (OTHERS) - [ASSIGN BUTTON] with the ▲ / ▼ / ◀ / ▶ /SET button.

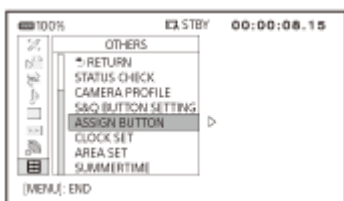

3 Select the ASSIGN button that you want to set with the ▲ / ▼ / ◀ / ▶ /SET button and press the button to enter.

4 Select the function that you want to assign with the ▲ / ▼ / ◀ / ▶ /SET button and press the button to enter.

5 Select [OK] with the ▲ / ▼ / ◀ / ▶ /SET button and press the button to assign the function.

**Note**

- When the camcorder is in Photo mode, the ASSIGN4 button is for the shutter release button only.



## Playing back movies

You can play movies on the camcorder.

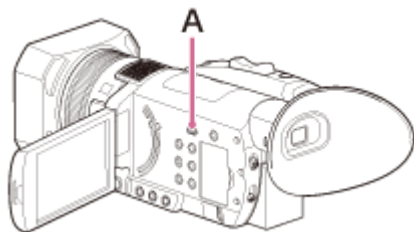

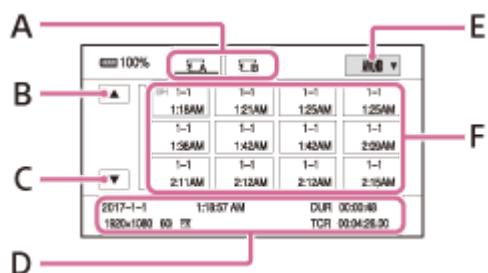

A: THUMBNAIL  (playback) button

- 1 Open the LCD panel.
- 2 Press the THUMBNAIL  (playback) button.
  - The THUMBNAIL screen appears after a few seconds.



- A: Memory card
- B: Previous
- C: Next
- D: Current movie data
- E: Playback mode
- F: Thumbnails of movies (You can turn on or off the date and time display on the thumbnails by pressing DISPLAY button.)

- 3 Touch the memory card you want to play back.
  -  : Memory card A
  -  : Memory card B
  - You can also select the memory card with the ▲ / ▼ / ◀ / ▶ /SET button.
- 4 Touch the playback mode, and select the desired file format of movies.
  - Movies that are recorded in the selected file format are displayed.



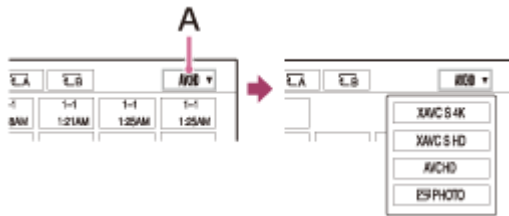

A: Playback mode

5 Touch twice the thumbnail of the movie you want to play back.

- You can also select the movie to be played back with the ▲/▼/◀/▶/SET button.
- The first touch of the thumbnail will show the information on the movie at the lower part of the LCD monitor.

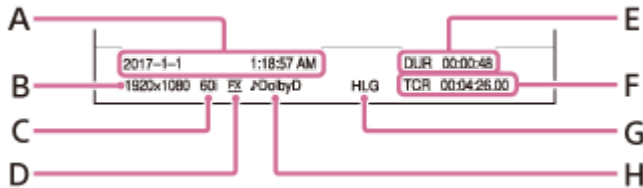

A: Date and time of recording started

B: Resolution

C: Frame rate

D: Recording mode

E: Duration

F: Time code of recording started (Time code is not displayed correctly when you play back memory card with no time code, or memory card with time code that the camcorder does not support.)

G: HLG (Hybrid Log-Gamma) recording (Appears when the movie is recorded with GAMMA set to HLG.)

H: DOLBY DIGITAL recording (Appears when audio is recorded in Dolby Digital format.)

- appears with the movie that has been most recently played back or recorded. If you touch the movie with , you can continue playback from the previous time.

6 The selected movie starts playing.

- During playback

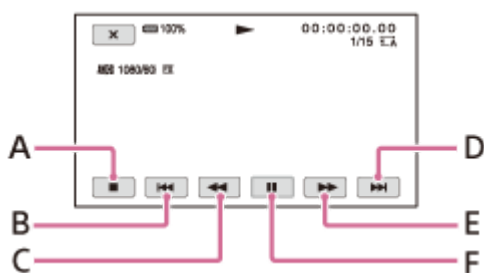

- During pause

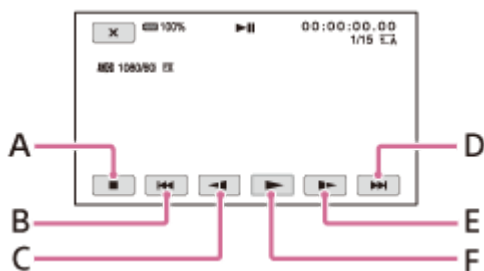

A: Stop

B: Previous

C: Fast reverse (during playback)/Slow reverse (during pause)

D: Next

E: Fast forward (during playback)/Slow forward (during pausing)  
F: Play/Pause

## To adjust the volume

Adjust the volume with MENU button -  (AUDIO SET) - [VOLUME].



## To return to the recording mode

Press the THUMBNAIL  (playback) button.

### Note

- Movies recorded using this camcorder may not be played back normally on devices other than this camcorder. Also, movies recorded on other devices may not play back properly on this camcorder.
- To play back HDR movies on a device other than the camcorder, you need an HDR compatible device that is set appropriately. When recording with XAVC S, metadata (additional information) which is needed to play back and display HDR movies, such as the color space and gamma, is recorded. If a device to play back or display movies supports these metadata, movies are automatically displayed with the appropriate settings. If a device does not support these metadata, you need make settings manually.  
Also, AVCHD recording with the camcorder does not support recording HDR metadata. To play back/display HDR movies properly, make settings manually or add metadata in editing.

### Hint

- When playback from the selected movie reaches the last movie, the screen returns to the thumbnail screen.
- The movie starts playing slowly by touching  during pause.
- The playback speed increases based on the number of times that you touch  / .

---

## Related Topic

- [VOLUME](#)
- [Recording movies](#)
- [REC SET](#)

## Playing back photos

You can play photos on the camcorder.

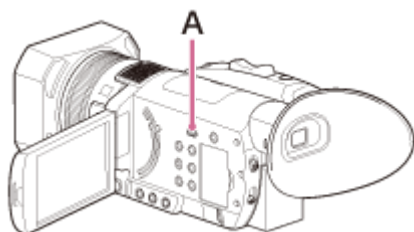

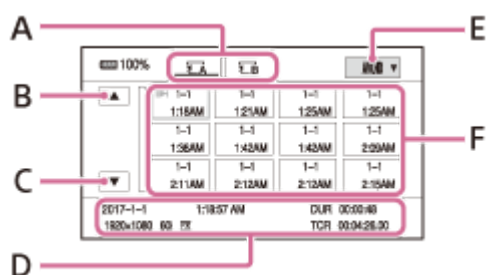

A: THUMBNAIL  (playback) button

- 1 Open the LCD panel.
- 2 Press the THUMBNAIL  (playback) button.
  - The THUMBNAIL screen appears after a few seconds.



- A: Memory card
- B: Previous
- C: Next
- D: Current photo data
- E: Playback mode
- F: Thumbnail of photos (You can turn on or off the date and time display on the thumbnails by pressing DISPLAY button.)

- 3 Touch the memory card you want to play back.

 A : Memory card A  
 B : Memory card B

- You can also select the memory card with the ▲ / ▼ / ◀ / ▶ /SET button.

- 4 Touch the playback mode, and select [  PHOTO ].

- Photos that are recorded in the selected file format are displayed.

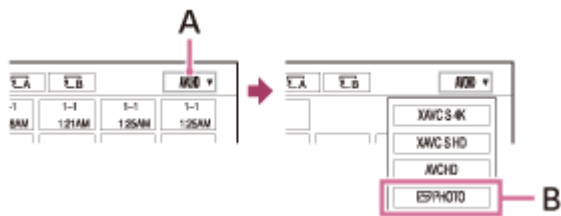

- A: Playback mode
- B: PHOTO

5 Touch twice the thumbnail of the photo you want to play back.

- You can also select the photo to be played back with the ▲ / ▼ / ◀ / ▶ / SET button.
- The first touch of the thumbnail will show the information on the photo at the lower part of the LCD monitor.



- A: Date and time of recording
- B: Number of pixels
- C: Image size

6 The selected photo starts playing.

- The following screen appears.

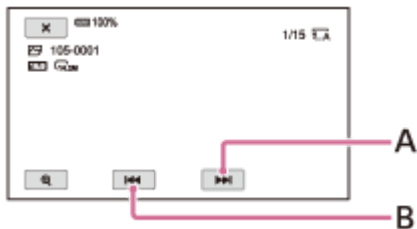

- A: Next
- B: Previous

### To enlarge

Touch (playback zoom) when playing back the photo.

You can adjust the zoom with / , or with the zoom lever.

When you touch the enlarged image, the touched point is displayed at the center of the screen.

### To return to the recording mode

Press the THUMBNAIL (playback) button.

#### Note

- Photos recorded using this camcorder may not be played back normally on devices other than this camcorder. Also, photos recorded on other devices may not play back properly on this camcorder.

### Related Topic

- [Shooting photos](#)



## Changing the screen display

You can display information such as time code, etc., on the image.

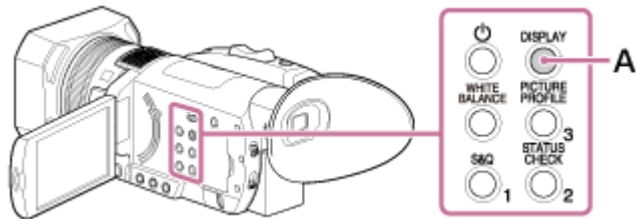

A: DISPLAY button

1 Press the DISPLAY button.

- The screen indicators turn on (displayed) and off (not displayed) as you press the button. In the recording mode, the screen changes in the order, detailed display - simple display - no display with each press of the button.

### Hint

- You can display the screen indicators during playback on a TV when you set MENU button -  (CAMERA SET) - [DISPLAY OUTPUT] to [ALL OUTPUT].

### Related Topic

- [DISPLAY OUTPUT](#)

## Displaying recording data ( DATA CODE)

You can display information, including date, time and camera data automatically stored during recording on the screen during playback.

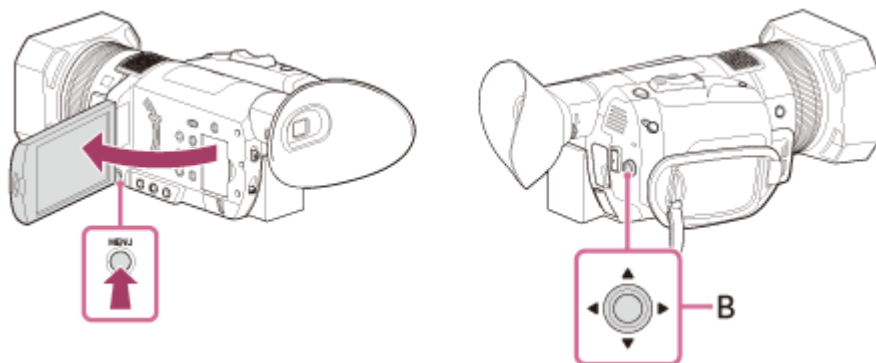

A: MENU button

B: ▲ / ▼ / ◀ / ▶ / SET button

- 1 Press the MENU button.
- 2 Select the data that you want to display on  (DISPLAY SET) – [DATA CODE] with the ▲ / ▼ / ◀ / ▶ / SET button.
  - You can also display the data with the ASSIGN button to which the DATA CODE function is assigned, during playback or pause.
  - When using the ASSIGN button, the screen changes in the order, date and time display - camera data display - no display with each press of the button.

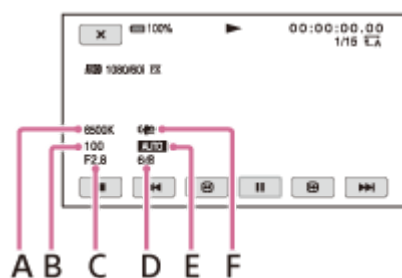

A: White balance ( **PWB** appears when playing images recorded with [WB PRESET] set to [MANU WB TEMP].)

B: Shutter speed

C: Iris

D: Gain

E: Exposure ( **AUTO** appears when playing images recorded with the iris, gain or shutter speed automatically adjusted. **MANUAL** appears when playing images recorded with the iris, gain or shutter speed manually adjusted.)

F: STEADYSHOT

### Note

- When you play back the memory card on other devices, the camera data may be displayed incorrectly. Confirm the correct camera data on your camcorder.

---

---

#### Related Topic

- [DATA CODE](#)
- [WB PRESET](#)
- [Assigning the functions to the ASSIGN buttons](#)

4-725-312-11(2) Copyright 2017 Sony Corporation



## Checking the settings in the camcorder ( STATUS CHECK)

You can check the settings of the following items.

- Audio settings
- Output settings
- Functions assigned to the ASSIGN buttons
- Camera settings
- Memory card information  
You can check the estimated used and free spaces.

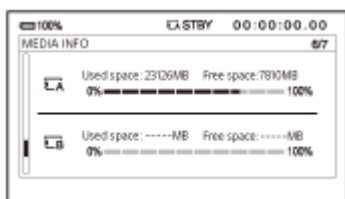

- Battery information  
You can check the remaining capacity of the attached battery.

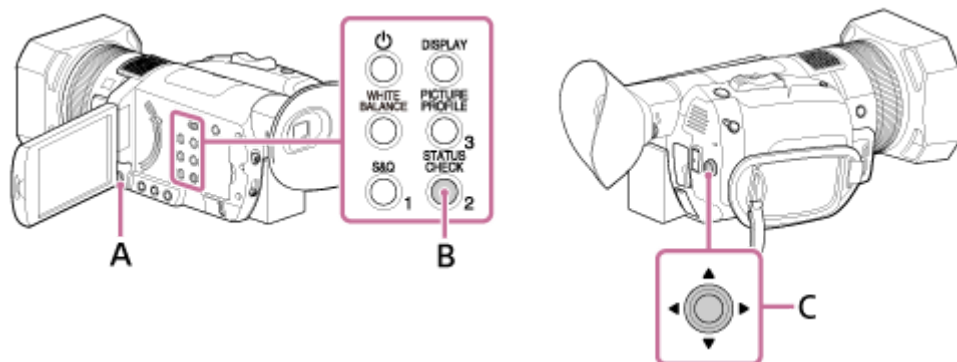
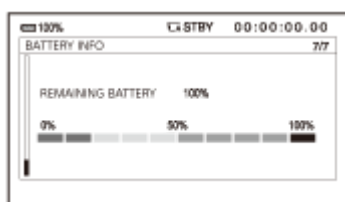

- A: MENU button  
B: STATUS CHECK button (assigned to the ASSIGN2 button by default)  
C: ▲ / ▼ / ◀ / ▶ / SET button

- 1 Press the STATUS CHECK button.
  - You can also display the STATUS CHECK screen by selecting MENU button - (OTHERS) - [STATUS CHECK].
- 2 Select the displayed item with the ▲ / ▼ / ◀ / ▶ / SET button.
  - The displayed items switch in the order of [AUDIO] - [OUTPUT] - [ASSIGN] - [CAMERA] - [MEDIA INFO] - [BATTERY INFO].
  - Setup items are displayed according to the status or shooting mode of the camcorder when it is turned on.

To hide the display

Press the STATUS CHECK button.

---

---

Related Topic

- [STATUS CHECK](#)
- [Assigning the functions to the ASSIGN buttons](#)

4-725-312-11(2) Copyright 2017 Sony Corporation

Digital 4K Video Camera Recorder  
FDR-AX700

## On the HDMI cable

---

- We recommend to use the supplied HDMI cable, an HDMI cable with the HDMI logo, or Sony HDMI cable.
- Copyright-protected images are not output from the HDMI OUT jack of the camcorder.
- Some devices may not function correctly (e.g., no sound or image) with this connection.
- Do not connect the HDMI OUT Terminal of the camcorder to an external device HDMI OUT Terminal, as malfunction may result.
- HDMI (High-Definition Multimedia Interface) is an interface to send both video/audio signals. The HDMI OUT Terminal outputs high quality images and digital audio.
- The camcorder is not compatible with the BRAVIA Sync Function.

## Viewing images on a 4K TV

You can play movies recorded in [XAVC S 4K], in high definition image quality by connecting the camcorder to a TV with an HDMI jack.

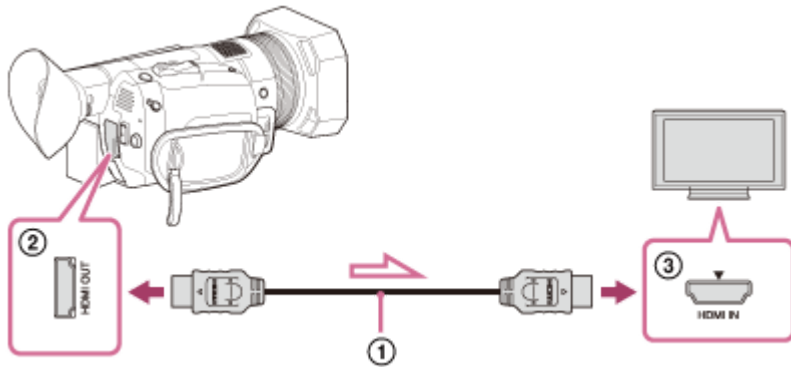

- 1 Connect the HDMI OUT terminal of the camcorder ( ② ) and HDMI input jack of the TV ( ③ ) with the HDMI cable ( ① ) (sold separately).
- 2 Switch the input on the TV to the connected jack.
- 3 Play the movie on the camcorder .

### When you cannot view images with [ AUTO ]

[OUTPUT SELECT] is set to [AUTO] in default setting which adjusts camcorder's output setting automatically depending on the connected TV. When you cannot play back images with [AUTO] after performing step 2, select  (REC/OUT SET) - [VIDEO OUT] - [HDMI] - one of the following output resolutions. If you select a setting other than following, the image will be played back with high definition quality.

- When 60i is selected
  - [2160p/1080p/480i]
  - [2160p/720p/480i]
  - [2160p/1080i/480i]
- When 50i is selected
  - [2160p/1080p/576i]
  - [2160p/720p/576i]
  - [2160p/1080i/576i]

#### Note

- Also refer to the instruction manual of the TV.
- When you view images on a TV, use the AC Adaptor (supplied) as the power source.
- Photos cannot be played in 4K image quality.
- The camcorder does not support BRAVIA Sync.
- To view images recorded with HDR on a TV, connect the camcorder to an HDR (HLG) compatible TV manufactured by Sony via a USB cable.

When you connect a TV with an HDMI cable, you need to change the image quality setting of the TV manually in order to display images properly. Set the image quality of the TV as follows;

- Gamma: Setting compatible with HLG
- Color mode: Setting compatible with BT.2020 or 709

---

#### Related Topic

- [Using the camcorder supplying power from a wall outlet \(wall socket\)](#)
- [VIDEO OUT](#)
- [REC SET](#)

4-725-312-11(2) Copyright 2017 Sony Corporation

## Viewing images on a high definition TV

You can play movies/photos in high definition image quality by connecting the camcorder to a TV with an HDMI jack.

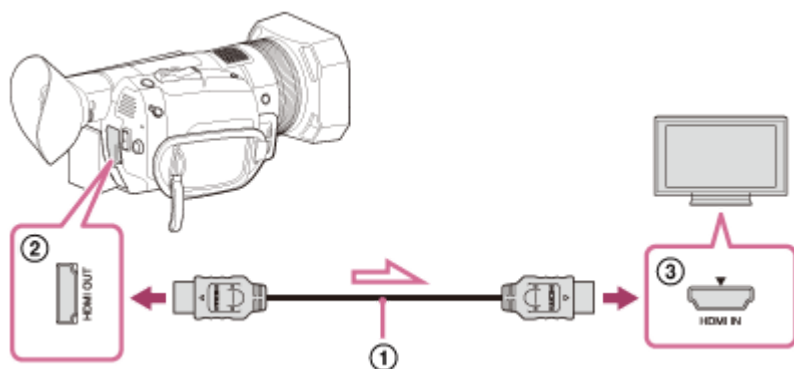

- 1 Connect the HDMI OUT T erminal of the camcorder ( ②) and HDMI input jack of the TV ( ③) with the HDMI cable ( ①) (sold separately).
- 2 Switch the input on the TV to the connected jack.
- 3 Play the movie/photo on the camcorder .

### When you cannot view images with [ AUTO]

[OUTPUT SELECT] is set to [AUTO] in default setting which adjusts camcorder's output setting automatically depending on the connected TV. When you cannot play back images with [AUTO] after performing step 2, select  (REC/OUT SET) - [VIDEO OUT] - [HDMI] - one of the following output resolutions.

- XAVC S 4K movies (When 60i is selected)
  - [1080p/480i]
  - [720p/480i]
  - [1080i/480i]
- XAVC S HD/AVCHD movies (When 60i is selected)
  - [2160p/1080p/480i]
  - [2160p/720p/480i]
  - [2160p/1080i/480i]
  - [1080p/480i]
  - [720p/480i]
  - [1080i/480i]
- XAVC S 4K movies (When 50i is selected)
  - [1080p/576i]
  - [720p/576i]
  - [1080i/576i]
- XAVC S HD/AVCHD movies (When 50i is selected)
  - [2160p/1080p/576i]
  - [2160p/720p/576i]

- [2160p/1080i/576i]
- [1080p/576i]
- [720p/576i]
- [1080i/576i]

#### Note

- Refer to the instruction manuals of the TV as well.
- Use the supplied AC Adaptor as the power source.
- If the TV does not have an HDMI input jack, use an AV cable (sold separately). Images are output in standard definition.
- The camcorder does not support BRAVIA Sync.

---

#### Related Topic

- [Using the camcorder supplying power from a wall outlet \(wall socket\)](#)
- [VIDEO OUT](#)
- [REC SET](#)

## Viewing images on a non-high-definition TV

Play back movies/photos on the camcorder by connecting to a TV with an AV cable (sold separately).

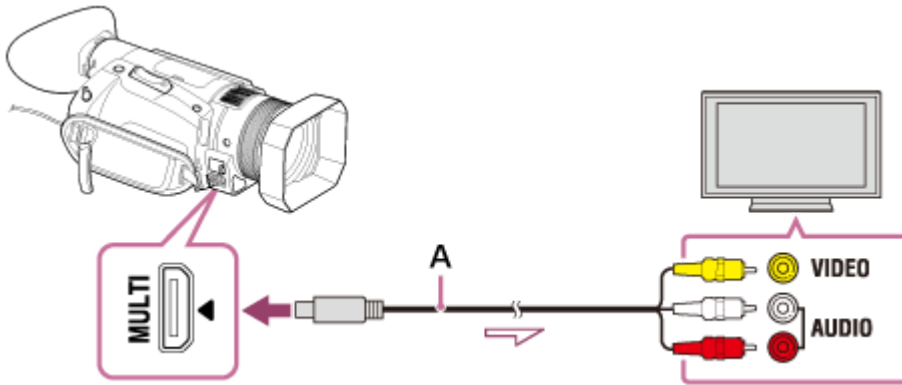

A: AV cable (sold separately)

- 1 Connect the Multi/Micro USB Terminal of the camcorder and VIDEO/AUDIO jack of the TV with the A V cable (sold separately).
- 2 Switch the input on the TV to the connected jack.
- 3 Play a movie/photo on the camcorder .

### Note

- Refer to the instruction manuals of the TV as well.
- When you view images on a TV, use the AC Adaptor (supplied) as the power source.
- Perform the setting of the MENU button - **↔** (REC/OUT SET) – [VIDEO OUT] – [DOWN CONVERT TYPE] to match the TV screen size.

### Related Topic

- [Using the camcorder supplying power from a wall outlet \(wall socket\)](#)
- [VIDEO OUT](#)



Digital 4K Video Camera Recorder  
FDR-AX700

## Notes on editing

---

- Some basic editing operations can be done on the camcorder. If you want to do advanced editing operations, install and use the PlayMemories Home software.
  - You cannot restore images once they are deleted. Save important movies and photos before deleting.
  - Do not remove the battery pack or the AC Adaptor from the camcorder while deleting or dividing the images. Doing so may damage the memory card.
  - Do not eject the memory card while deleting or dividing images saved on the memory card.
- 

### Related Topic

- [Import and utilize images on your computer \(PlayMemories Home\)](#)
- [Protecting movies and photos \(PROTECT\)](#)
- [Deleting selected movies/photos](#)
- [Dividing a movie](#)

## Protecting movies and photos ( PROTECT)

Protect movies and photos to avoid deleting them by mistake.

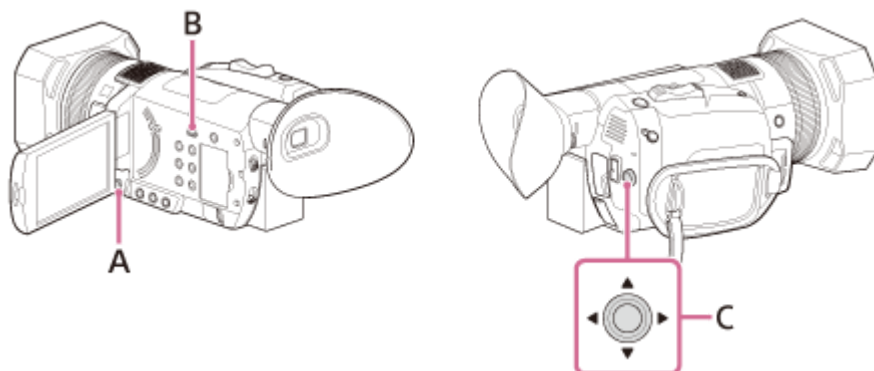

A: MENU button

B: THUMBNAIL  (playback) button

C :  /SET button

1 Press the THUMBNAIL  (playback) button.

- The thumbnail screen is displayed.

2 Press the MENU button.

3 Select  (EDIT) - [PROTECT] with the  /SET button.

4 Touch movies or photos that you want to protect.

-  appears on the selected thumbnails.

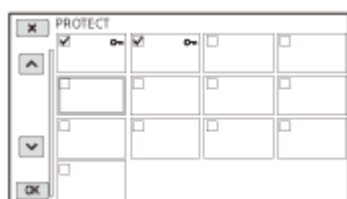

- Press and hold the image down to preview the image. Touch  to return to the previous screen.
- You can select up to 100 images at one time.

5 Touch  and follow the on-screen instructions to touch .

### To undo the protection

Touch thumbnails with  in step 4 to hide .



## Deleting selected movies/photos



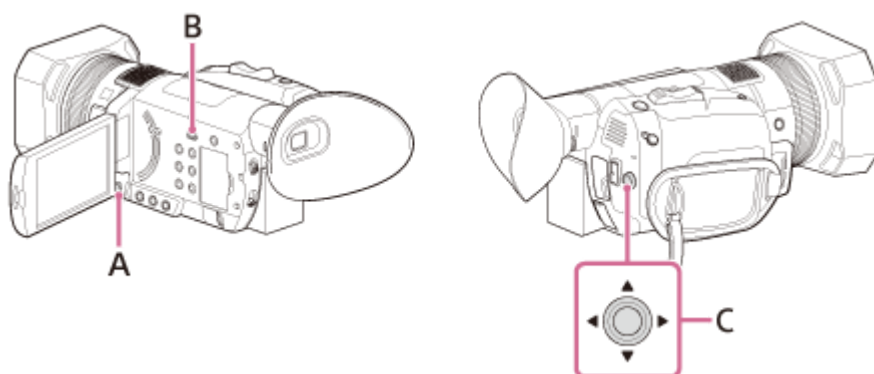





You can free media space by deleting movies and still images from memory card.







A: MENU button

B: THUMBNAIL  (playback) button

C:  /  /  /  /  / SET button

- 1 Press the THUMBNAIL  (playback) button.
  - The thumbnail screen is displayed.
- 2 Press the MENU button.
- 3 Select  (EDIT) - [DELETE] with the  /  /  /  /  / SET button.
- 4 Touch the movies or photos that you want to delete.
  -  appears on the selected thumbnails.



- Press and hold the image down to preview the image. Touch  to return to the previous screen.
  - You can select up to 100 images at one time.
  -  appears at the upper right corner on the thumbnail of protected images.
  - No check box appears on the thumbnail of protected images.
- 5 Touch , then follow the on-screen instructions to touch .

### Note

- You cannot restore images once they are deleted.
- Do not remove the battery pack, AC Adaptor or memory card that contains the movies or photos from your camcorder during the operation. It may damage the memory card.

- You cannot delete protected movies and photos. Undo the protection before you try to delete them.
- Save important movies and photos onto the computers in advance.

#### Hint

- To delete all data recorded on the memory card and recover all the recordable space of it, format the memory card.

---

#### Related Topic

- [Protecting movies and photos \(PROTECT\)](#)
- [Saving movies](#)
- [MEDIA FORMAT](#)

4-725-312-11(2) Copyright 2017 Sony Corporation

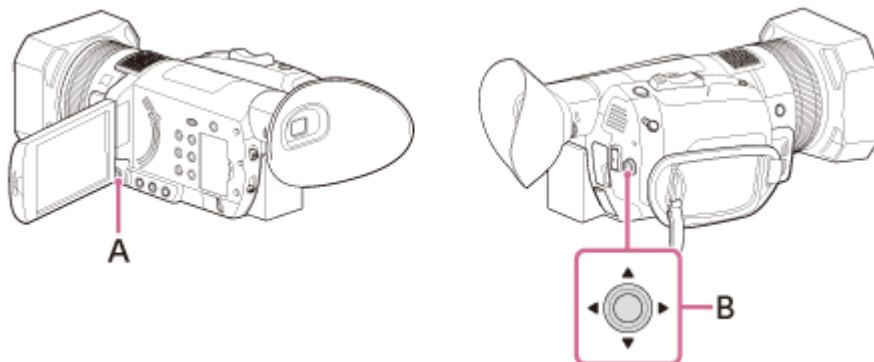

## Dividing a movie

You can divide a movie at a designated point.



A: MENU button

B: ▲/▼/◀/▶/SET button

- 1 Press the MENU button while playing back a movie.
- 2 Select  (EDIT) - [DIVIDE] with the ▲/▼/◀/▶/SET button.
- 3 Touch  at the point where you want to divide.

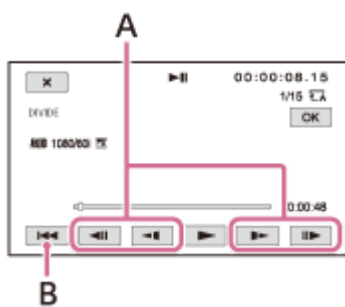

A: After you select the point with  make fine adjustment with these buttons.

B: Returns to the beginning of the selected movie.

- 4 Touch  - .

### Note

- You cannot restore movies once they are divided.
- Do not remove the battery pack, AC Adaptor or memory card that contains the movies to be divided from your camcorder during the operation. It may damage the memory card.
- A slight difference may occur from the point where you touch  and the actual dividing point, as the camcorder selects the dividing point based in about half-second increments.
- Movies recorded in XAVC S cannot be divided.

---

---

Related Topic

- [Playing back movies](#)

4-725-312-11(2) Copyright 2017 Sony Corporation

Digital 4K Video Camera Recorder  
FDR-AX700

## Saving movies

---

How to save images in each format is as follows.

### XAVC S 4K

How to save:

Save images on your computer using the PlayMemories Home software. (\*)

Saving format:

XAVC S 4K

### XAVC S HD

How to save:

Save images on your computer using the PlayMemories Home software. (\*)

Saving format:

XAVC S HD

### AVCHD

How to save:

Save images on your computer using the PlayMemories Home software.

Saving format:

AVCHD

\* For the latest storage environment, visit the following website.

<http://www.sony.net/>

#### Hint

- You may also save by connecting a recorder with an AV cable (sold separately). The image quality will be standard definition.

---

#### Related Topic

- [Installing the PlayMemories Home software in your computer](#)
- [Creating a disc with a recorder](#)



## Import and utilize images on your computer ( PlayMemories Home)

PlayMemories Home allows you to import movies and photos to your computer to use them in a variety of ways. PlayMemories Home is necessary to import XAVC S or AVCHD movies to your computer.

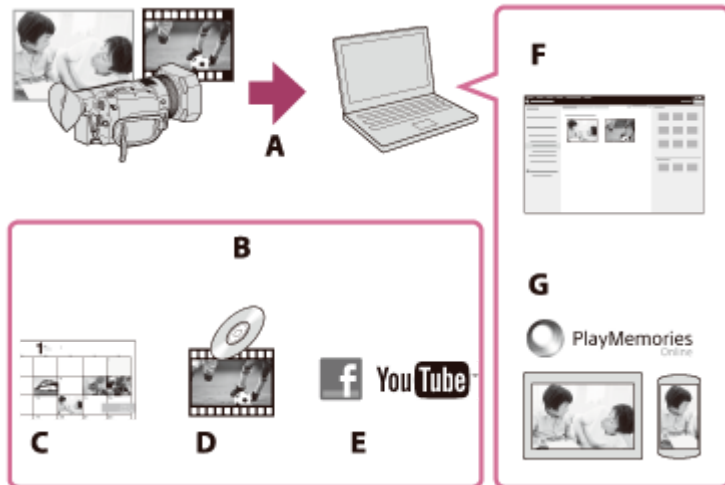

A: Import images from the camcorder

B: The functions below are also available on a Windows PC

C: View images in a calendar

D: Create a movie disc

E: Upload images to online services

F: Play the imported images

G: Share images on PlayMemories Online

### Installing the PlayMemories Home software in your computer

PlayMemories Home can be downloaded from the following URL.

<http://www.sony.net/pm/>

#### Related Topic

- [Checking the computer system](#)
- [Installing the PlayMemories Home software in your computer](#)

Digital 4K Video Camera Recorder  
FDR-AX700

## Checking the computer system

---

You can check the system requirements for software at the following URL.

<http://www.sony.net/pcenv/>

## Installing the PlayMemories Home software in your computer

Installing the PlayMemories Home software on your computer enables you to make use of your recorded images.

- 1 Access the following download page using an Internet browser on your computer to download the PlayMemories Home software.

<http://www.sony.net/pm/>

- Install the software according to the on-screen instructions.
- When the installation has completed, PlayMemories Home starts.
- If the PMB (Picture Motion Browser) software is installed on your computer, it will be overwritten by the PlayMemories Home software. Use PlayMemories Home, the successor software of PMB.

- 2 Connect the camcorder and your computer with the micro USB Cable.

- If the PlayMemories Home software is already installed on your computer, connect the camcorder to your computer.

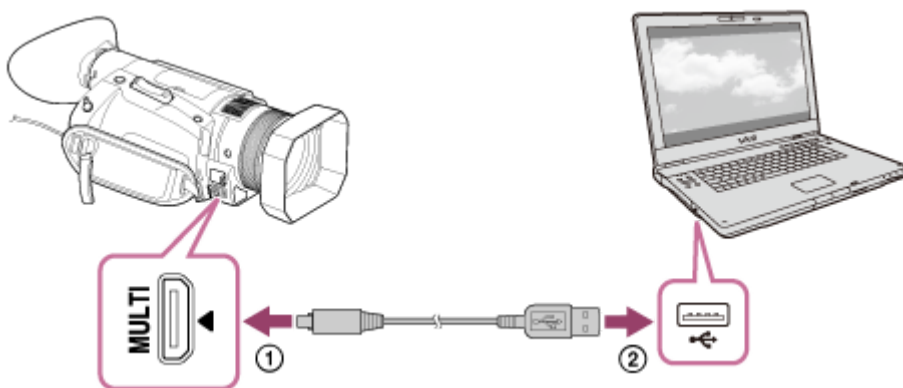

- ① To the Multi/Micro USB Terminal  
② To the USB jack of your computer

### Note

- Log on to your computer as an administrator.
- You may need to restart your computer. When prompted to restart, follow the on-screen instructions.
- Depending on the usage environment, DirectX can then be installed.

### Hint

- For details on PlayMemories Home, refer to the help of PlayMemories Home.

### Related Topic

- [Checking the computer system](#)





Digital 4K Video Camera Recorder  
FDR-AX700

## Disconnecting the camcorder from the computer

---

Disconnect the camcorder from the computer connected with the USB Cable.

- 1 Click  in the task tray , and then click  .
- 2 Click the message displayed on the computer screen.
- 3 Select  - [YES] on the LCD monitor , and then disconnect the USB Cable.

### Note

- If you use a Mac computer, drag and drop the memory card or the drive icon to the Trash before disconnecting. The connection with the computer is released.
- If you use a Windows 7, Window 8.1 or Windows 10 computer, a disconnection icon may not be displayed. In this case, you can release the connection without performing the above operations.

Digital 4K Video Camera Recorder  
FDR-AX700

## Creating a Blu-ray disc

---

You can create a Blu-ray disc with an AVCHD movie previously imported to a computer.

To create a Blu-ray disc, the “BD Add-on Software” must be installed.

<http://support.d-imaging.sony.co.jp/BDUW/>

- Your computer must support the creation of Blu-ray discs.
- BD-R (unrewritable) and BD-RE (rewritable) media are available for creating Blu-ray discs. You cannot add contents to either type of disc after creating the disc.
- You cannot save XAVC S movies onto a Blu-ray disc.

## Creating a disc with a recorder

You can copy images on the camcorder onto a disc or video cassette. Connect the camcorder to a disc recorder with an AV cable (sold separately).

### Note

- Connect the AC Adaptor to the camcorder, and then connect the AC Adaptor to a wall outlet (wall socket).
- Refer to the instruction manual supplied with the device connected.

- 1 Insert a recording medium in a recording device (a disc recorder , etc.).
  - If your recording device has an input selector, set it to the input mode.
- 2 Connect the camcorder to the recording device with an A V cable (sold separately).
  - Connect the camcorder to the input jacks of the recording device.

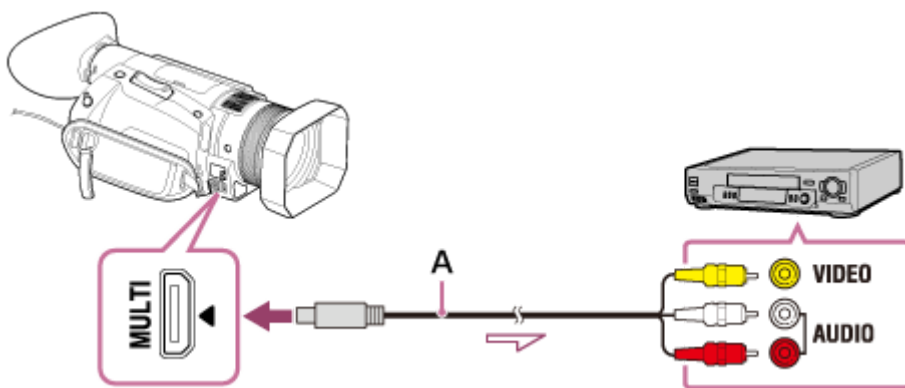



A: AV cable (sold separately)

- 3 Start playback on the camcorder , and record it on the recording device.
- 4 When copying is finished, stop the recording device, and then the camcorder .

### Note

- Set the aspect ratio according to the display monitor such as TV by pressing MENU button - select  (REC/OUT SET) - [VIDEO OUT] - [DOWN CONVERT TYPE].
- You cannot copy images to recorders connected with the HDMI cable.
- Since copying is performed via analog data transfer, the image quality may deteriorate.
- Images will be copied with standard definition image quality.
- When you connect a monaural device, connect the yellow plug of an AV cable (sold separately) to the video input jack, and the white (left channel) or the red (right channel) plug to the audio input jack on the device.

### Hint

- To not show the counter on the display of the connected device, press the MENU button - select  (DISPLAY SET) - [DISPLAY OUTPUT] - [LCD PANEL].
- To copy the date and time or shooting information, press the ASSIGN button which DATA CODE function is assigned and make your desired setting. Then, press the MENU button - select  (DISPLAY SET) - [DISPLAY OUTPUT] - [ALL OUTPUT].

---

#### Related Topic

- [Using the camcorder supplying power from a wall outlet \(wall socket\)](#)
- [DATA CODE](#)
- [VIDEO OUT](#)
- [DISPLAY OUTPUT](#)
- [Assigning the functions to the ASSIGN buttons](#)

4-725-312-11(2) Copyright 2017 Sony Corporation



Digital 4K Video Camera Recorder  
FDR-AX700

## About the PlayMemories Mobile software

---

To perform operations of [CTRL W/SMARTPHONE], the PlayMemories Mobile application for smartphone is required. Install the application from the applications store for your smartphone. If PlayMemories Mobile is already installed in your smartphone, update the application to the latest version. For details on PlayMemories Mobile, visit the PlayMemories Mobile support page (<http://www.sony.net/pmm/>).

### Note

- PlayMemories Mobile is not guaranteed to work on all smartphones and tablets.

---

### Related Topic

- [CTRL W/SMARTPHONE](#)

## Connecting to an NFC-enabled smartphone or tablet

You can easily connect the camcorder to your NFC-enabled Android smartphone or tablet.

### Note

- Make sure that your smartphone is not in sleep mode and the screen is unlocked in advance.

- 1 Install PlayMemories Mobile on your smartphone.
  - If PlayMemories Mobile is already installed on your smartphone, update the software to the latest version.
- 2 Set the camcorder to the shooting mode.
  - You can use the NFC function only when **N** (N Mark) is displayed on the screen.
- 3 Touch **N** (N mark) of your smartphone to **N** (N mark) of the camcorder .
  - Make sure that **N** (N mark) is displayed on the LCD monitor of the camcorder.
  - Hold the camcorder and your smartphone together and keep them still for about 1-2 seconds until PlayMemories Mobile starts up on your smartphone.

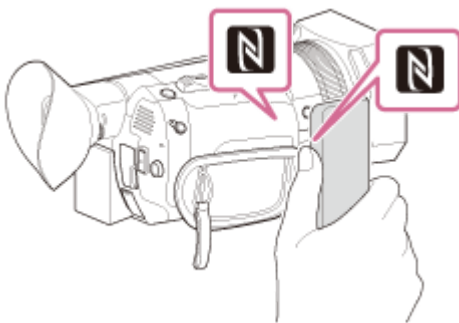

When the camcorder is in shooting mode  
[CTRL W/SMARTPHONE] starts up.

### Note

- To use the one-touch functions of the camcorder, an NFC-enabled smartphone or tablet is required.
- NFC (Near Field Communication) is an international standard for short-range wireless communication technology.
- If the connection is not made successfully, try the procedures shown in “ [Connecting to your Android smartphone or tablet \(by entering an SSID and password\)](#) .”

### Related Topic

- [About the PlayMemories Mobile software](#)
- [Connecting to your Android smartphone or tablet \(by entering an SSID and password\)](#)
- [Using your smartphone or tablet as a wireless remote commander](#)



## Connecting to a smartphone or tablet using the QR Code

You can easily connect the camcorder to your smartphone or tablet by reading the QR Code.

- 1 Install PlayMemories Mobile on your smartphone.
  - If PlayMemories Mobile is already installed on your smartphone, update the software to the latest version.
- 2 Press the MENU button - select  (NETWORK SET) - [CTRL W/SMARTPHONE].
  - The QR Code, SSID, password and device name are displayed.



- 3 Start up PlayMemories Mobile, and select [  Scan QR Code of the Camera] from the screen of PlayMemories Mobile.

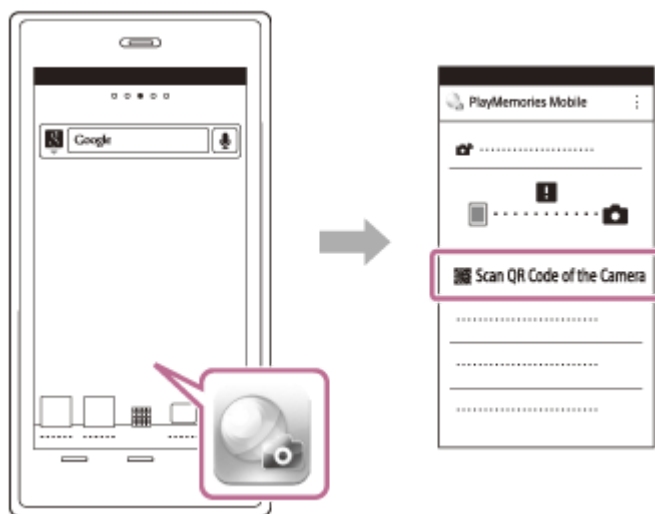

- 4 Select [OK]. (If a message appears, select [OK] again.)



5 With your smartphone, read the QR Code displayed on the LCD monitor of the camcorder

#### Android

- When [Connect with the camera?] is displayed, select [Connect].

#### iPhone/iPad

- Follow the on-screen instructions and install the profile (setting information).



- On Home, select [Settings] - [Wi-Fi].

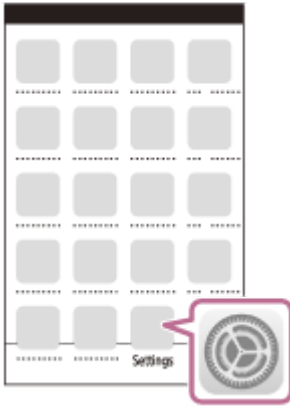

- Select the SSID of the camcorder.



- Go back to the Home screen and start up PlayMemories Mobile.

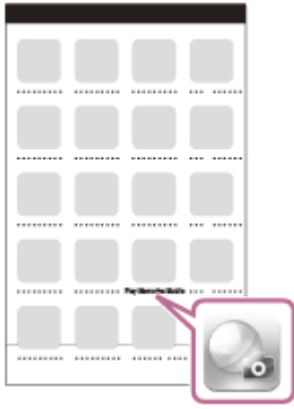

### Note

- If the camcorder cannot be connected with the smartphone by NFC or by reading the QR Code, connect by using the SSID and the password.

### Hint

- Once the QR Code is read and the connection has been successfully established, the SSID (DIRECT-xxxx) and the password of the camcorder will be registered onto your smartphone. Subsequent Wi-Fi connections between the camcorder and your smartphone will only require selecting the SSID of the camcorder registered on your smartphone.

---

### Related Topic

- [Connecting to your Android smartphone or tablet \(by entering an SSID and password\)](#)
- [Connecting to your iPhone or iPad \(by entering an SSID and password\)](#)
- [About the PlayMemories Mobile software](#)
- [Using your smartphone or tablet as a wireless remote commander](#)
- [CTRL W/SMARTPHONE](#)

Digital 4K Video Camera Recorder  
FDR-AX700

## Connecting to your Android smartphone or tablet (by entering an SSID and password)

Shows how to connect the camcorder to your Android smartphone or tablet. Display the SSID and password in advance by selecting [CTRL W/SMARTPHONE] on the camcorder.

- 1 Start up PlayMemories Mobile on the smartphone.



- 2 Select the SSID displayed on the camcorder



- 3 Enter the password displayed on the camcorder



## Related Topic

- [About the PlayMemories Mobile software](#)
- [Using your smartphone or tablet as a wireless remote commander](#)
- [CTRL W/SMARTPHONE](#)

4-725-312-11(2) Copyright 2017 Sony Corporation



## Connecting to your iPhone or iPad (by entering an SSID and password)

Shows how to connect the camcorder to your iPhone or iPad. Display the SSID and password in advance by selecting [CTRL W/SMARTPHONE] on the camcorder.

- 1 Open the settings menu on your iPhone.

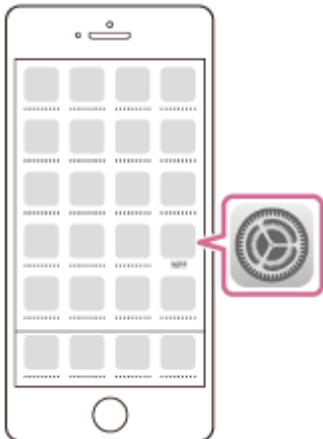

- 2 Select Wi-Fi.

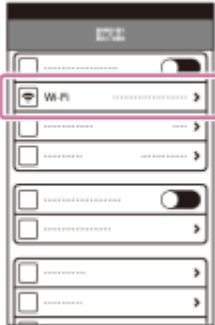

- 3 Select the SSID displayed on the camcorder .



- 4 Enter the password displayed on the camcorder .



5 Confirm that the SSID displayed on the camcorder is selected.

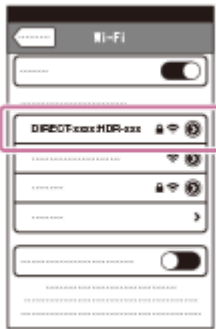

6 Go back to Home and start up PlayMemories Mobile.

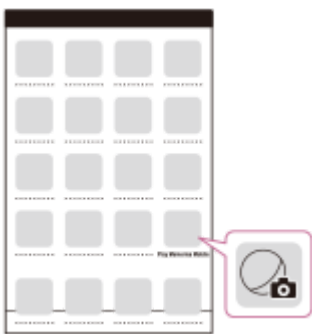



#### Related Topic

- [About the PlayMemories Mobile software](#)
- [Using your smartphone or tablet as a wireless remote commander](#)
- [CTRL W/SMARTPHONE](#)

## Using your smartphone or tablet as a wireless remote commander

You can operate the camcorder using your smartphone or tablet as a wireless remote commander.

- 1 Install PlayMemories Mobile on your smartphone.
    - If PlayMemories Mobile is already installed in your smartphone, update the software to the latest version.
  - 2 On the camcorder, press the MENU button - select  (NETWORK SET) - [CTRL W/SMARTPHONE].
    - The QR Code, SSID, password and device name are displayed on the LCD monitor of the camcorder. The camcorder is now ready to be operated using your smartphone.
- 
- 3 Start PlayMemories Mobile, select [ Scan QR Code of the Camera] - [ OK] - [OK], then scan the QR Code displayed on the LCD monitor of the camcorder with your smartphone or tablet.
    - Connect to the camcorder using your smartphone.
    - For details on connecting your smartphone, see "Related Topic."
  - 4 Operate the camcorder using your smartphone.

### Note

- Movies and photos are recorded on the camcorder and are not stored on the smartphone.
- The operation methods and display screens for the application are subject to change without notice by future upgrades.
- This application is not guaranteed to work on all smartphones and tablets.

### Hint

- For the latest supported OS, refer to the download page of PlayMemories Mobile.

### Related Topic

- [About the PlayMemories Mobile software](#)
- [Connecting to an NFC-enabled smartphone or tablet](#)
- [Connecting to a smartphone or tablet using the QR Code](#)
- [Connecting to your Android smartphone or tablet \(by entering an SSID and password\)](#)
- [Connecting to your iPhone or iPad \(by entering an SSID and password\)](#)
- [CTRL W/SMARTPHONE](#)



## Using your smartphone or tablet as a wireless remote commander using the NFC function (NFC one-touch remote)

You can operate the camcorder using your NFC-enabled smartphone or tablet as a wireless remote commander.



### Note

- Make sure that your smartphone is not in sleep mode and the screen is unlocked in advance.

- 1 Install PlayMemories Mobile on your smartphone.
  - If PlayMemories Mobile is already installed in your smartphone, update the software to the latest version.

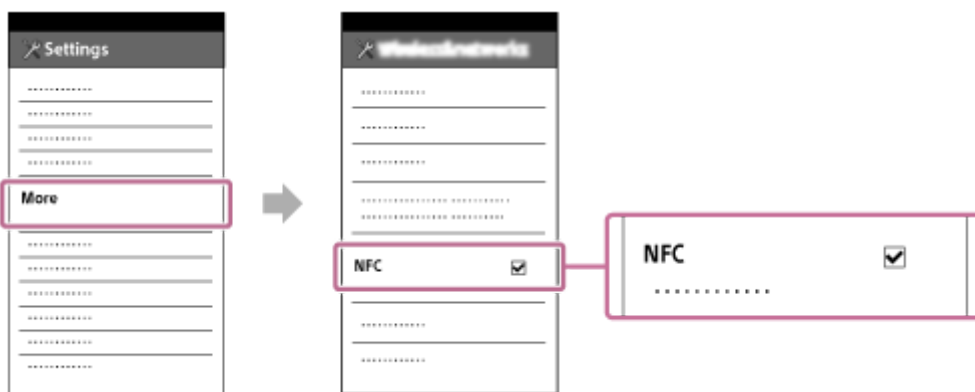
- 2 Select [ Settings ] on the smartphone, then select [ More ] and place a checkmark next to [ NFC ].



- 3 Enter the recording mode and touch  (N mark) of your smartphone to  (N mark) of the camcorder .

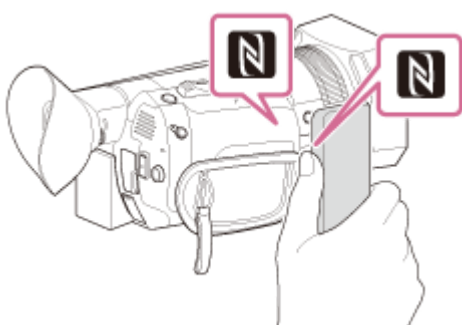

- Make sure that  (N mark) is displayed on the LCD monitor of the camcorder.
- Hold the camcorder and your smartphone together and keep them still for about 1-2 seconds until PlayMemories Mobile starts up on your smartphone.

- 4 Operate the camcorder using your smartphone.

### Note

- Movies and photos are recorded on the camcorder and are not stored on the smartphone.
- The operation methods and display screens for the application are subject to change without notice by future upgrades.

- This application is not guaranteed to work on all smartphones and tablets.
- If the connections is not made successfully, try the procedures shown in “ [Connecting to your Android smartphone or tablet \(by entering an SSID and password\)](#) .”

#### Hint

- For the latest supported OS, refer to the download page of PlayMemories Mobile.

---

#### Related Topic

- [About the PlayMemories Mobile software](#)
- [Connecting to an NFC-enabled smartphone or tablet](#)
- [Connecting to a smartphone or tablet using the QR Code](#)
- [Connecting to your Android smartphone or tablet \(by entering an SSID and password\)](#)
- [CTRL W/SMARTPHONE](#)

## Setting up menu items

You can change various settings or make detailed adjustments using the menu items displayed on the LCD monitor. The camcorder has various menu items under each of 8 menu categories.

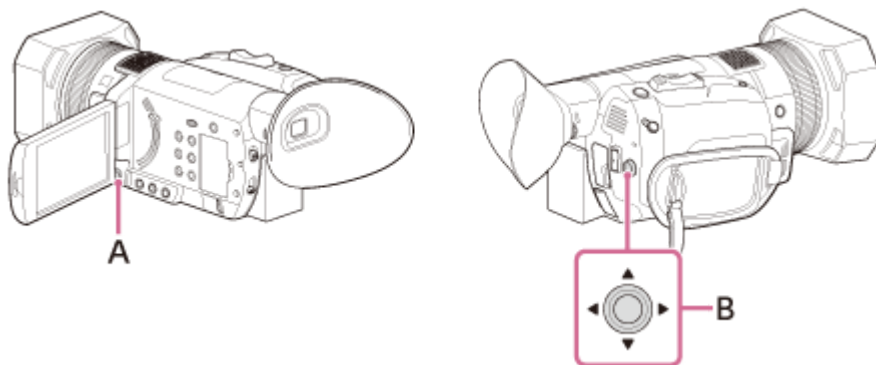

A: MENU button

B: ▲/▼/◀/▶/SET button

1 Press the MENU button.

- The menu screen appears.

2 Use the ▲/▼/◀/▶/SET button to select the desired menu icon, then press the button.

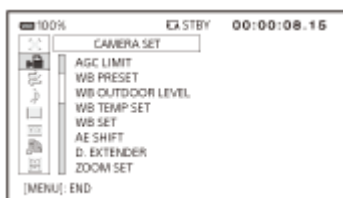

- (CAMERA SET) (appears when shooting)
- (REC/OUT SET)
- (AUDIO SET)
- (DISPLAY SET)
- (TC/UB SET)
- (NETWORK SET)
- (OTHERS)
- (EDIT)

– The (EDIT) menu appears when pressing the MENU button on the thumbnail or playback screen.

3 Use the ▲/▼/◀/▶/SET button to select the item that you want to set, then press the button.

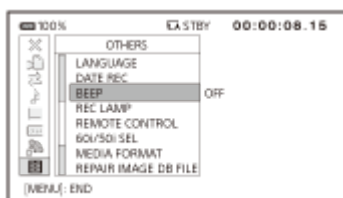

- 4 Use the ▲/▼/◀/▶/SET button to select the desired setting, then press the button.

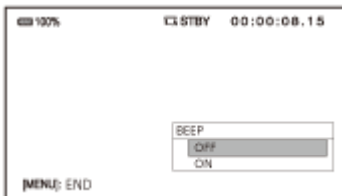

- 5 Press the MENU button to turn the menu screen off.
- To return to the previous screen, select [↶ RETURN].

#### Note

- The available menu items vary depending on the state of the camcorder during recording or playback.
- The available menu items vary depending on the shooting mode (Movie mode/Photo mode).
- Items and setting values that are not available due to other settings are grayed out.

#### Hint

- You can assign the function of the MENU button to the ASSIGN button.

---

#### Related Topic

- [How to use the keyboard](#)
- [Assigning the functions to the ASSIGN buttons](#)





Digital 4K Video Camera Recorder  
FDR-AX700

## How to use the keyboard

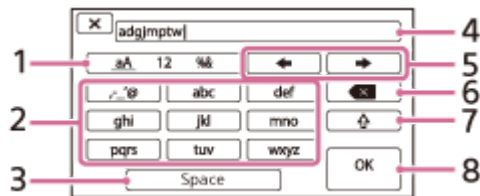
A keyboard is displayed on the LCD monitor when text needs to be entered.



1. Switch character types  
Each time you touch the key, the type of character to be input switches between letters, numerals and symbols.
2. Keyboard  
Each time you touch the key, the displayed character switches between the choices available.  
For example: If you want to enter "abd"  
Select [abc], touching it once to display "a" - touch  - select [abc], touching it twice to display "b" - select [def] touching it once to display "d."
3. Space  
Enters a space.
4. Input box  
The characters you entered are displayed. ◀ indicates the limit to text length.
5. Move cursor  
Moves the cursor in the input box to the right or left.
6. Delete  
Deletes the character preceding the cursor.
7.   
Switches the next character to a capital or small letter.
8. Fix  
Finalizes the entry.

To cancel text entry, select .

Digital 4K Video Camera Recorder  
FDR-AX700

## ISO/GAIN SEL

---

You can switch the displayed value between the ISO sensitivity and gain when adjusting the ISO sensitivity or gain manually by pressing ISO/GAIN (Movie mode only).

- 1 MENU button -  (CAMERA SET) - [ ISO/GAIN SEL ] .

### Descriptions of menu items

ISO:

Adjusts the ISO sensitivity.

GAIN:

Adjusts the gain.

#### Note

- The value of the ISO sensitivity or gain is stored individually.
- This item does not appear during Photo mode. When pressing ISO/GAIN during Photo mode, you can adjust the ISO sensitivity only.

---

### Related Topic

- [Adjusting the gain](#)
- [Adjusting the ISO sensitivity](#)

Digital 4K Video Camera Recorder  
FDR-AX700

## AUTO ISO LIMIT

You can set the upper limit for the ISO sensitivity when adjusting it automatically.

In Photo mode, only ISO appears.

You can use this function during Movie mode when [ISO/GAIN SEL] is set to [ISO].

- 1 MENU button -  (CAMERA SET) - [AUTO ISO LIMIT].

### Descriptions of menu items

OFF, ISO200—ISO4000:

Select the upper limit for the ISO sensitivity.

The upper limit is not set when selecting [OFF].

#### Note

- This setting is not effective when adjusting the ISO sensitivity manually.
- When selecting picture profile1 through 10, the selectable range of AUTO ISO LIMIT depends on the [GAMMA] setting in [PICTURE PROFILE] as follows.
  - STANDARD: ISO200–ISO4000
  - STILL: ISO200–ISO5000
  - CINE1: ISO250–ISO5000
  - CINE2: ISO200–ISO4000
  - CINE3: ISO320–ISO6400
  - CINE4: ISO400–ISO8000
  - ITU709: ISO200–ISO4000
  - ITU709(800%): ISO1600–ISO32000
  - S-LOG2: ISO1600–ISO32000
  - S-LOG3: ISO1600–ISO32000
  - HLG: ISO400–ISO8000
  - HLG1: ISO200–ISO4000
  - HLG2: ISO320–ISO6400
  - HLG3: ISO400–ISO8000

### Related Topic

- [Adjusting the ISO sensitivity](#)
- [ISO/GAIN SEL](#)
- [Shooting with the picture quality that is set in advance \(PICTURE PROFILE\)](#)
- [Changing the picture profile](#)

Digital 4K Video Camera Recorder  
FDR-AX700

## AGC LIMIT

---

You can set the upper limit for AGC (Auto Gain Control).

[AGC LIMIT] appears during Movie mode only.

[AGC LIMIT] is available when [GAIN] is selected in [ISO/GAIN SEL], and [AUTO ISO LIMIT] is available when [ISO] is selected in [ISO/GAIN SEL],

① MENU button -  (CAMERA SET) - [AGC LIMIT] .

### Descriptions of menu items

OFF, 24dB – 0dB (3 dB increments):

Select the upper limit for AGC.

The upper limit is not set when selecting [OFF].

#### Note

- This setting is not effective when adjusting the gain manually.

---

### Related Topic

- [Adjusting the gain](#)
- [ISO/GAIN SEL](#)

Digital 4K Video Camera Recorder  
FDR-AX700

## WB PRESET

---

You can select the preset when setting the white balance.

- 1 MENU button -  (CAMERA SET) - [WB PRESET].

### Descriptions of menu items

#### OUTDOOR:

- When shooting a night scene, neon lighting, fireworks, etc.
- When shooting a sunrise, sunset, etc.
- Under daylight fluorescent lamp

You can adjust the offset level with [WB OUTDOOR LEVEL].

#### INDOOR:

- Where lighting conditions change, such as at a party place, etc.
- Under video light, such as in a studio, etc.
- Under a sodium or mercury lamp

#### MANU WB TEMP:

Sets to the color temperature that is selected on [MANU WB TEMP].

You can set the color temperature between 2300K and 15000K (the default setting is 6500K).

#### Hint

- You can select the preset by using the WHITE BALANCE button.
- You can assign this function to the ASSIGN button.

---

#### Related Topic

- [Adjusting the color to the natural tone \(WHITE BALANCE\)](#)
- [Storing the adjusted white balance value in memory A or B](#)
- [WB OUTDOOR LEVEL](#)
- [WB TEMP SET](#)
- [Assigning the functions to the ASSIGN buttons](#)

Digital 4K Video Camera Recorder  
FDR-AX700

## WB OUTDOOR LEVEL

---

You can set an offset value when [WB PRESET] is set to [OUTDOOR].

1 MENU button -  (CAMERA SET) - [WB OUTDOOR LEVEL].

### Descriptions of menu items

-7 – 0 – +7:

Bluish – Normal – Reddish

---

### Related Topic

- [Adjusting the color to the natural tone \(WHITE BALANCE\)](#)
- [WB PRESET](#)

Digital 4K Video Camera Recorder  
FDR-AX700

## WB TEMP SET

---

You can set the color temperature when [WB PRESET] is set to [MANU WB TEMP].

The color temperature is the measure, indicated in units called Kelvin (K), that indicates light color emitted from a light source such as sunlight, artificial lighting, etc. The color becomes warmer as the color temperature unit (K) is lower, and colder as the color temperature unit (K) is higher, regardless of the temperature or brightness of the light source. The color temperature of sunlight is about 5000K to 6000K.

- 1 MENU button -  (CAMERA SET) - [WB TEMP SET].

### Descriptions of menu items

2300K – 15000K (100K increments) :

Select the color temperature.

---

### Related Topic

- [Adjusting the color to the natural tone \(WHITE BALANCE\)](#)
- [WB PRESET](#)



Digital 4K Video Camera Recorder  
FDR-AX700

## WB SET

---

You can store the adjusted white balance value in memory A or B. Unless a white balance is readjusted, values will remain even after the power has been turned off.

Use this function when fixing the white balance according to the lighting conditions of shooting environment.

- 1 Turn the MANUAL dial to select  A or  B during adjusting the white balance, then press MENU button - select  (CAMERA SET) - [WB SET].
- 2 Frame a white object such as a piece of paper that fills the LCD monitor under the same lighting conditions as your subject.
- 3 Press SET button.

The adjusted value is stored in  A or  B. The stored color temperature appears for about 3 seconds.

### Hint

- You can assign this function to the ASSIGN button.

---

### Related Topic

- [Adjusting the color to the natural tone \(WHITE BALANCE\)](#)
- [WB PRESET](#)
- [Assigning the functions to the ASSIGN buttons](#)



Digital 4K Video Camera Recorder  
FDR-AX700

## AE SHIFT

---

You can adjust the exposure according to user's preference.

- 1 MENU button -  (CAMERA SET) - [AE SHIFT] – select the desired item.

### Descriptions of menu items

#### ON/OFF:

Sets the AE SHIFT function to on/off.

- ON: The selected value (-2.0EV for example) appears.
- OFF: Does not use the AE Shift function.

#### LEVEL:

Adjusts the exposure with ▲ / ▼ / ◀ / ▶ /SET button.

- -2.0EV - 0EV - +2.0EV: Dark - Standard - Bright

#### Note

- This function is not effective while you adjust the iris, shutter speed, and gain all manually.

#### Hint

- You can assign this function to the ASSIGN button.
- You can change the setting directly on the shooting standby screen with ▲ / ▼ / ◀ / ▶ /SET button (Direct Menu).

---

### Related Topic

- [Adjusting the iris](#)
- [Adjusting the gain](#)
- [Adjusting the ISO sensitivity](#)
- [Adjusting the shutter speed](#)
- [Assigning the functions to the ASSIGN buttons](#)
- [Performing shooting adjustment with Direct Menu](#)

Digital 4K Video Camera Recorder  
FDR-AX700

## D. EXTENDER

---

You can double the magnification of the displayed image when shooting movies (XAVC S HD/AVCHD movie only).

- 1 MENU button -  (CAMERA SET) - [D. EXTENDER].

### Descriptions of menu items

OFF:

Does not magnify images.

ON:

Magnify the image double.

#### Hint

- You can assign this function to the ASSIGN button.

---

### Related Topic

- [Assigning the functions to the ASSIGN buttons](#)

Digital 4K Video Camera Recorder  
FDR-AX700

## ZOOM SET

---

You can set the movement of the zoom operation.

- 1 MENU button -  (CAMERA SET) - [ZOOM SET] – select the desired item.

### Descriptions of menu items

#### ZOOM TYPE:

You can select the zoom type.

- OPTICAL ZOOM ONLY: Uses only the optical zoom. You can zoom up to 12×.
- ON[CLEAR IMAGE ZOOM] : Uses the clear image zoom in addition to the optical zoom.  
You can zoom up to 24×, which includes 12× optical zoom for AVCHD or XAVC S HD, up to 18×, which includes 12× optical zoom for XAVC S 4K.
- ON[DIGITAL ZOOM] : Uses the digital zoom in addition to the optical zoom and clear image zoom.  
You can zoom up to 192× but the image quality deteriorates within the range where  appears.

#### SPEED ZOOM:

You can increase the zoom speed of the zoom lever.

- OFF: Does not use the speed zoom function.
- ON: Uses the speed zoom function.

#### Note

- When [SPEED ZOOM] is set to [ON], the zoom operation sound may be recorded.
- The following functions do not work while using the digital zoom.
  - FACE DETECTION
  - FOCUS AREA
  - LOCK-ON AF

#### Hint

- Clear image zoom maintains an image quality that is close to the original.

---

### Related Topic

- [Adjusting the zoom with the zoom lever](#)
- [Adjusting the zoom with the manual lens ring](#)
- [FACE DETECTION](#)
- [FOCUS AREA](#)
- [Adjusting focus by tracking the desired subject \(LOCK-ON AF\)](#)

Digital 4K Video Camera Recorder  
FDR-AX700

## STEADYSHOT (Movie)

---

You can set the camera shake reduction when shooting.

- 1 MENU button -  (CAMERA SET) - [ STEADYSHOT].

### Descriptions of menu items

STANDARD (  ):

Uses SteadyShot function when shooting under relatively stable conditions.

ACTIVE (  ):

Uses SteadyShot function with more powerful effect.

OFF (  ):

Does not use SteadyShot function.

This setting is recommended when you use a tripod.

#### Note

- When [ACTIVE] is selected, the angle of view shifts 1.08 times toward the telephoto side.

#### Hint

- You can assign this function to the ASSIGN button.

---

### Related Topic

- [Assigning the functions to the ASSIGN buttons](#)

Digital 4K Video Camera Recorder  
FDR-AX700

## STEADYSHOT (Photo)

---

You can set the camera shake reduction when shooting.

- 1 MENU button -  (CAMERA SET) - [ STEADYSHOT].

### Descriptions of menu items

ON (  ):

Uses SteadyShot function.

OFF (  ):

Does not use SteadyShot function.

This setting is recommended when you use a tripod.

#### Hint

- You can assign this function to the ASSIGN button.

---

### Related Topic

- [Assigning the functions to the ASSIGN buttons](#)

## FOCUS AREA

You can change the focusing area for auto focus mode (Movie mode only). Use this function when the layout or range of moving subject is decided in advance, or it is difficult to focus on the intended subject.

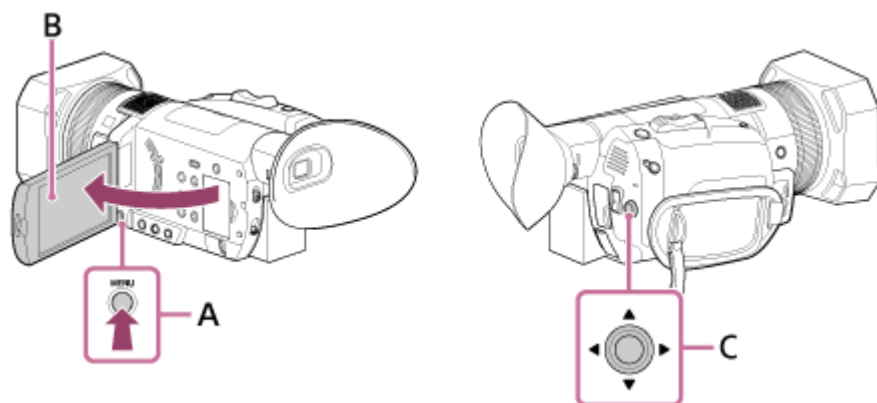

- A: MENU button  
B: LCD monitor  
C: ▲/▼/◀/▶/SET button

- 1 Press the MENU button.
- 2 Select  (CAMERA SET) - [ FOCUS AREA] with the ▲/▼/◀/▶/SET button.

### Description of menu items

#### WIDE:

Focuses on a subject covering the whole range of the screen automatically.

You can specify the subject that you want to focus by touching it during the phase detection AF frames appear.

- Touch operation is possible only when [LOCK-ON AF] is set to [OFF].
- When [FACE DETECTION] is set to [ON], the focus area is not displayed and touch operation is disabled.

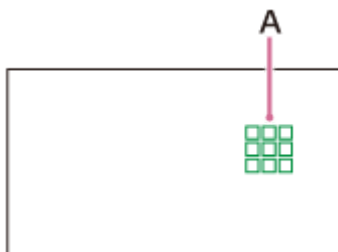

#### A: Phase detection AF frames

White frames are the area to where the camcorder tries to focus. The frame color changes to green after becoming in focus.

#### ZONE:

Select a zone by touching on the area selection screen or using the ▲/▼/◀/▶/SET button. The camcorder then focuses automatically in the zone.

The zone is divided 3 rows and 3 columns (9 zones).

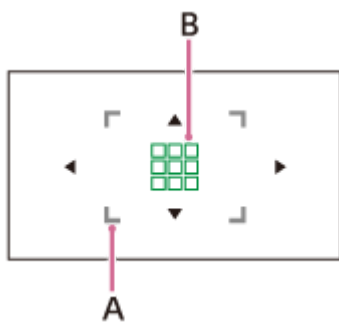

A: Focus area

Indicates the area where the auto focus works.

B: Phase detection AF frames

White frames are the area to where the camcorder tries to focus. The frame color changes to green after becoming in focus.

CENTER:

Focuses automatically on a subject in the center of the image.

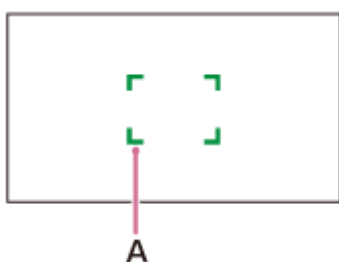

A: Focus frame

Indicates the area where the auto focus works.

The frame color is gray while the camcorder tries to focus on the subject and it turns to green when the subject is in focus.

FLEXIBLE SPOT :

Move the focus frames to a desired point by touching on the area selection screen or using the ▲ / ▼ / ◀ / ▶ /SET button. You can focus on a small subject in a narrow area.

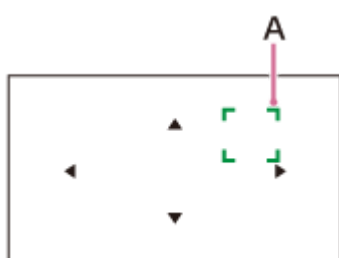

A: Focus frame

Indicates the area where the auto focus works.

The frame color is gray while the camcorder tries to focus on the subject and it turns to green when the subject is in focus.

### Note

- [FOCUS AREA] is fixed to [WIDE] on the following cases.
  - Using the clear image zoom or digital zoom.
  - [INTELLIGENT AUTO] or [SCENE SELECTION] is set for [AUTO MODE SET].
  - LOCK-ON AF is set.
- [FOCUS AREA] setting is not available in Super Slow Motion recording.
- The [FOCUS AREA] setting is not enabled when using a zoom other than the optical zoom and the focus area frames are displayed as a dotted line.

## Hint

- You can select the focus speed for auto focus mode during movie recording.
- You can select AF tracking sensitivity for auto focus mode during movie recording.
- You can assign [FOCUS AREA] to the ASSIGN button.
- When [FOCUS POSITION] is assigned to the ASSIGN button and [FOCUS AREA] is set to [FLEXIBLE SPOT] or [ZONE], you can display the area selection screen directly by pressing the button.
- You can set whether to display the phase detection AF area or phase detection AF frames.

---

## Related Topic

- [Adjusting the focus automatically](#)
- [Phase detection AF](#)
- [AF DRIVE SPEED](#)
- [AF SUBJ. TRACK SET](#)
- [PHASE AF FRAMES](#)
- [PHASE DETECT. AF AREA](#)
- [Assigning the functions to the ASSIGN buttons](#)



## AF DRIVE SPEED

---

You can select the auto focus speed during recording movies.

- 1 MENU button -  (CAMERA SET) - [AF DRIVE SPEED].

### Descriptions of menu items

1[SLOW] - 7[FAST]:

Sets the auto focus speed.

When setting to the slow side, the excessive focus movement is reduced. The focus switches smoothly when the subject to be focused is changed and shooting impressive images is possible. This is suitable for shooting a scene in constant motion or a scene where an object does not move too much.

When setting to the fast side, the AF drive speed is set to fast and you can keep focusing on the subject with fast movement. This is suitable for shooting active scenes, such as sports. The larger the value you set, the faster the AF drive speed.

#### Note

- This setting is not available under the following conditions.
  - When [NIGHTSHOT] is set to [ON].
  - When [FILE FORMAT] is [XAVC S HD] and [REC FORMAT] is 120p/100p.
  - When [HIGH FRAME RATE] is selected in [S&Q MOTION].
- The auto focus function is not available in the Super Slow Motion recording mode.

#### Hint

- You can assign this function to the ASSIGN button.

---

### Related Topic

- [Assigning the functions to the ASSIGN buttons](#)

Digital 4K Video Camera Recorder  
FDR-AX700

## AF SUBJ. TRACK SET

You can set the auto focus range to track a subject or auto focus sensitivity to switch between subjects during movie recording.

- 1 MENU button -  (CAMERA SET) - [AF SUBJ. TRACK SET] - select the desired item.

### Descriptions of menu items

#### AF TRACKING DEPTH :

Sets the AF tracking area for the subject in the depth direction.

- 1[NARROW] to 5[WIDE]: Set to the Wide side when shooting the subject with large motion in the depth direction. Set to the Narrow side when shooting the subject that does not move so much.  
When setting to the Wide side, you can focus on subjects whose distance from the camera changes one after another. The larger the setting value you set, the faster the focusing another subject.  
When setting to the Narrow side, you can keep focusing the desired subject under the condition where the another subject crosses the desired subject. It is suitable for keeping focusing the desired subject.

#### AF SUBJ. SWITCH. SENS.:

Sets the switching time to focus another subject when the subject is switched or is not tracked because the subject moves out from the focus area.

- 1[LOCKED ON] - 5[RESPONSIVE]: Set to the Locked on side when shooting one subject. Set to the Responsive side when shooting plurality of subjects.  
When setting to the Responsive side, you can focus subjects one after another when the subject is switched. The larger the setting value you set, the faster the focusing another subject.  
When setting to the Locked on side, you can keep focusing the desired subject because the tracking does not respond quickly even if the subject moves out from the focus area. It is suitable for keeping focusing the desired subject.

### Setting example of AF TRACKING DEPTH/AF SUBJ. SWITCH. SENS.

- Trains/races:  
Situation that you want to track the subject with fast and regular motion and nothing exists in front of it.  
AF TRACKING DEPTH: 4 / AF SUBJ. SWITCH. SENS.: 5
- Sports/wild animals:  
Situation that you want to keep tracking the particular subject with fast and irregular motion.  
AF TRACKING DEPTH: 4/ AF SUBJ. SWITCH. SENS.: 2
- Landscape/macro :  
Situation that you want to focus on the subject without delay which contains less motion but much scene changes.  
AF TRACKING DEPTH: 1/ AF SUBJ. SWITCH. SENS.: 5
- Party/festival:  
Situation that you want to keep tracking a particular subject with moderate motion, or situation which contains persons in front who are not main subject.  
AF TRACKING DEPTH: 1/ AF SUBJ. SWITCH. SENS.: 1

#### Note

- This setting is not available under the following conditions.
  - When [NIGHTSHOT] is set to [ON].
  - When [FILE FORMAT] is [XAVC S HD] and [REC FORMAT] is 120p/100p.
  - When [HIGH FRAME RATE] is selected in [S&Q MOTION].
- Auto focus function is not available in the Super Slow Motion recording mode.

### Hint

- You can assign this function to the ASSIGN button.

---

### Related Topic

- [Assigning the functions to the ASSIGN buttons](#)

4-725-312-11(2) Copyright 2017 Sony Corporation

Digital 4K Video Camera Recorder  
FDR-AX700

## LOCK-ON AF

---

You can track a subject you select by touching on the LCD monitor and adjust the focus automatically.

- 1 MENU button -  (CAMERA SET) - [ LOCK-ON AF ].

### Descriptions of menu items

OFF:

Disables the lock-on AF function.

ON:

Enables the lock-on AF function.

---

---

### Related Topic

- [Adjusting focus by tracking the desired subject \(LOCK-ON AF\)](#)

Digital 4K Video Camera Recorder  
FDR-AX700

## FACE DETECTION

---

The camcorder can detect the face and focus on it.  
[FACE DETECTION] is available only with auto focus.

- 1 MENU button -  (CAMERA SET) - [FACE DETECTION].

### Descriptions of menu items

OFF:

Does not use the Face Detection function.

ON:

Uses the Face Detection function.

When the faces are detected, frames appear.

#### Hint

- You can assign this function to the ASSIGN button.

---

### Related Topic

- [Focusing on a detected face \(FACE DETECTION\)](#)
- [Adjusting the focus automatically](#)
- [Assigning the functions to the ASSIGN buttons](#)

Digital 4K Video Camera Recorder  
FDR-AX700

## SLOW & QUICK (S&Q MOTION)

By shooting with a frame rate that is different from the playback frame rate, you can record images to be played back as slow motion or quick motion images. The images recorded with the Slow & Quick Motion function appear smoother than slow or fast-forward playback of images recorded at normal speed (XAVC S HD, XAVC S 4K only).  
The setting value differs depending on the setting of  (OTHERS) - [60i/50i SEL].

- 1 MENU button -  (CAMERA SET) - [SLOW & QUICK] - [S&Q MOTION] - select the desired item.

### Descriptions of menu items

#### EXECUTE:

Displays the Slow & Quick Motion recording screen.

#### HIGH FRAME RATE:

Sets the high speed recording format (XAVC S HD only).



Setting value differs depending on the setting of [REC FORMAT] and [FRAME RATE].

- OFF: Does not record movies with high frame rate.
- ON: Records movies with high frame rate.



#### REC FORMAT:

Sets the recording format for the Slow & Quick Motion recording (bit-rate, image size, scanning system).

When selecting [60i]:

- When selecting [XAVC S 4K] on  (REC/OUT SET) - [REC SET] - [FILE FORMAT]
  - 2160/30p 100Mbps, 2160/30p 60Mbps, 2160/24p 100Mbps, 2160/24p 60Mbps
- When selecting [XAVC S HD] on  (REC/OUT SET) - [REC SET] - [FILE FORMAT]
  - [HIGH FRAME RATE] is set to [ OFF]: 1080/60p 50Mbps, 1080/30p 50Mbps, 1080/24p 50Mbps
  - [HIGH FRAME RATE] is set to [ ON]: 1080/60p 50Mbps, 1080/30p 25Mbps, 1080/24p 25Mbps

When selecting [50i]:

- When selecting [XAVC S 4K] on  (REC/OUT SET) - [REC SET] - [FILE FORMAT]
  - 2160/25p 100Mbps, 2160/25p 60Mbps
- When selecting [XAVC S HD] on  (REC/OUT SET) - [REC SET] - [FILE FORMAT]
  - [HIGH FRAME RATE] is set to [ OFF]: 1080/50p 50Mbps, 1080/25p 50Mbps
  - [HIGH FRAME RATE] is set to [ ON]: 1080/50p 50Mbps, 1080/25p 25Mbps

#### FRAME RATE:

Sets the frame rate for the Slow & Quick Motion recording.

When selecting [60i]:

- When selecting [ OFF] in [ HIGH FRAME RATE]: 1fps, 2fps, 4fps, 8fps, 15fps, 30fps, 60fps
- When selecting [ ON] in [ HIGH FRAME RATE]: 120fps

When selecting [ 50i]:

- When selecting [ OFF] in [ HIGH FRAME RATE]: 1fps, 2fps, 3fps, 6fps, 12fps, 25fps, 50fps
- When selecting [ ON] in [ HIGH FRAME RATE]: 100fps

**Hint**

- When [FILE FORMAT] is set to [ XAVC S 4K], 60fps or 50fps cannot be selectable.
- When [FILE FORMAT] is set to [ XAVC S 4K], [HIGH FRAME RATE] is set to [ OFF].
- You can set this function with ASSIGN1/S&Q button.
- You can assign this function to the ASSIGN button.

About the playback speed by the [REC FORMAT] and [ FRAME RATE] settings for Slow & Quick Motion recording

The playback speeds based on the recording format and frame rate setting are as follows. The playback speeds differ depending on the setting of  (OTHERS) - [60i/50i SEL].

- When selecting [ XAVC S 4K] on  (REC/OUT SET) - [REC SET] - [FILE FORMAT]

When selecting [ 60i]

Frame rate	Recording format	
	2160/24p	2160/30p
30 fps	80% slow	100% (standard)
15 fps	160% quick	200% quick
8 fps	300% quick	375% quick
4 fps	600% quick	750% quick
2 fps	1,200% quick	1,500% quick
1 fps	2,400% quick	3,000% quick

When selecting [ 50i]

Frame rate	Recording format
	2160/25p
50 fps	50% slow
25 fps	100% (standard)
12 fps	208% quick

6 fps	417% quick
3 fps	833% quick
2 fps	1,250% quick
1 fps	2,500% quick

- When selecting [ XAVC S HD] on ⇄ (REC/OUT SET) - [REC SET] - [FILE FORMAT]

When selecting [ 60i]

Frame rate	Recording format		
	1080/24p	1080/30p	1080/60p
120 fps	20% slow	25% slow	50% slow
60 fps	40% slow	50% slow	100% (standard)
30 fps	80% slow	100% (standard)	200% quick
15 fps	160% quick	200% quick	400% quick
8 fps	300% quick	375% quick	750% quick
4 fps	600% quick	750% quick	1,500% quick
2 fps	1,200% quick	1,500% quick	3,000% quick
1 fps	2,400% quick	3,000% quick	6,000% quick

When selecting [ 50i]

Frame rate	Recording format	
	1080/25p	1080/50p
100 fps	25% slow	50% slow
50 fps	50% slow	100% (standard)
25 fps	100% (standard)	200% quick
12 fps	208% quick	417% quick
6 fps	417% quick	833% quick
3 fps	833% quick	1,667% quick
2 fps	1,250% quick	2,500% quick
1 fps	2,500% quick	5,000% quick

---

Related Topic



- Recording with Slow & Quick Motion
- Recording with Super Slow Motion
- SLOW & QUICK (SUPER SLOW MOTION)
- REC SET
- 60i/50i SEL
- Assigning the functions to the ASSIGN buttons

4-725-312-11(2) Copyright 2017 Sony Corporation

Digital 4K Video Camera Recorder  
FDR-AX700

## SLOW & QUICK (SUPER SLOW MOTION)

You can record slower movies than movies that are recorded with the Slow & Quick Motion recording.

The Super Slow Motion recording is compatible with [ XAVC S HD] only.

The setting items differ depending on the setting of  (OTHERS) - [60i/50i SEL].

- 1 MENU button -  (CAMERA SET) - [SLOW & QUICK] - [ SUPER SLOW MOTION] - select the desired item.

### Descriptions of menu items

#### EXECUTE:

Displays the Super Slow Motion recording screen.

#### REC FORMAT:

Sets the recording format for the Super Slow Motion recording (bit-rate, image size, scanning system).

When selecting [ 60i]:

- 1080/60p 50Mbps, 1080/30p 50Mbps, 1080/24p 50Mbps

When selecting [ 50i]:

- 1080/50p 50Mbps, 1080/25p 50Mbps

#### FRAME RATE:

Sets the frame rate for the Super Slow Motion recording.

When selecting [ 60i]:

- 240fps, 480fps, 960fps



When selecting [ 50i]:

- 250fps, 500fps, 1000fps

#### REC TIMING:

You can select the timing to start recording when pressing the ST  ART/STOP button.

- START TRIGGER

Starts/stops recording by pressing the ST  ART/STOP button after displaying the  SUPER SLOW MOTION recording screen.

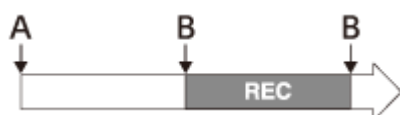

- END TRIGGER

Starts recording just after displaying the SUPER SLOW MOTION recording screen. Recording stops by pressing the START/STOP button.

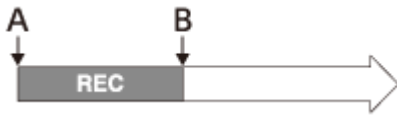

- END TRIGGER HALF

Works equally to [ END TRIGGER] but the recording time is reduced to a half.

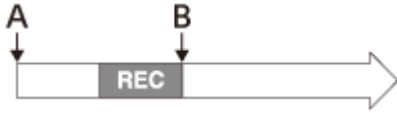

A: Select [ EXECUTE] on the SUPER SLOW MOTION screen.

B: Press the START/STOP button

REC: During recording

**Hint**

- You can set this function with the ASSIGN1/S&Q button.
- You can assign this function to the ASSIGN button.

About the playback speed by the [REC FORMAT] and [FRAME RATE] settings for Super Slow Motion recording

The playback speeds based on the recording format and frame rate setting are as follows.

The playback speeds differ depending on the setting of [OTHERS] – [60i/50i SEL].

- When selecting [ 60i]

Frame rate	Recording format		
	1080/24p	1080/30p	1080/60p
960 fps	2.5% slow	3.125% slow	6.25% slow
480 fps	5% slow	6.25% slow	12.5% slow
240 fps	10% slow	12.5% slow	25% slow

- When selecting [ 50i]

Frame rate	Recording format	
	1080/25p	1080/50p
1,000 fps	2.5% slow	5% slow
500 fps	5% slow	10% slow
250 fps	10% slow	20% slow

About the recording time by the [REC FORMATT] and [FRAME RATE] settings for Super Slow Motion recording

The recording times based on the recording format and frame rate setting are as follows.  
 The recording times differ depending on the setting of  (OTHERS) – [60i/50i SEL].

- When selecting [ 60i]

Frame rate	Recording format		
	START TRIGGER	END TRIGGER	END TRIGGER HALF
960 fps	3 sec.	3 sec.	1 sec.
480 fps	4 sec.	4 sec.	2 sec.
240 fps	5 sec.	5 sec.	2 sec.

- When selecting [ 50i]

Frame rate	Recording format		
	START TRIGGER	END TRIGGER	END TRIGGER HALF
1,000 fps	3 sec.	3 sec.	1 sec.
500 fps	4 sec.	4 sec.	2 sec.
250 fps	5 sec.	5 sec.	2 sec.

---

Related Topic

- [Recording with Super Slow Motion](#)
- [Recording with Slow & Quick Motion](#)
- [SLOW & QUICK \(S&Q MOTION\)](#)
- [REC SET](#)
- [60i/50i SEL](#)
- [Assigning the functions to the ASSIGN buttons](#)

Digital 4K Video Camera Recorder  
FDR-AX700

## AUTO MODE SET

You can shoot with an optimum setting in matching with various scene (Movie mode only).

- 1 MENU button -  (CAMERA SET) - [AUTO MODE SET].

### Descriptions of menu items

#### AUTO:

Sets to an optimum setting in matching with an imaging scene automatically .

#### INTELLIGENT AUTO:

Sets to an optimum setting by detecting the following scenes.

- Face detection:  (Portrait),  (Baby)
- Scene detection:  (Backlight),  (Landscape),  (Night Scene),  (Spotlight),  (Low Brightness),  (Macro)
- Camera-shake detection:  (Walk),  (Tripod)

[ STEADYSHOT] is set to [ ACTIVE] automatically , and the angle of view shifts 1.08 times toward the telephoto side.

#### SCENE SELECTION:

Sets to an optimum setting in matching with the scene that is selected on [ SCENE SELECTION SET].

#### Hint

- When [FILE FORMAT] in [ REC SET] is set to [ XAVC S 4K], [AUTO MODE SET] is fixed to [ AUTO].
- You can assign this function to the ASSIGN button.

### Related Topic

- [SCENE SELECTION SET](#)
- [STEADYSHOT \(Movie\)](#)
- [Assigning the functions to the ASSIGN buttons](#)

Digital 4K Video Camera Recorder  
FDR-AX700

## SCENE SELECTION SET

---

You can select the scene setting when [ AUTO MODE SET] is set to [ SCENE SELECTION] (Movie mode only).

1 MENU button -  (CAMERA SET) - [ SCENE SELECTION SET].

### Descriptions of menu items

 NIGHT SCENE:

Shoots a night view with a proper exposure, using a tripod (sold separately).



 SUNRISE&SUNSET:

Shoots the scenes under the glow of sunset/sunrise vividly .



 FIREWORKS:

Shoots fireworks with optimal exposure.



 LANDSCAPE:

Shoots distant subjects clearly .

This setting also prevents your camcorder from focusing on any glass or mesh in windows between the camcorder and the subject.



 PORTRAIT:

Brings out the subject, such as people or flowers, while creating a soft background.



#### SPOTLIGHT:

Prevents people's faces from appearing excessively white when subjects are lit by strong light.



#### BEACH:

Takes the vivid blue of the ocean or a lake.



#### Note

- When [SCENE SELECTION ] is set, the following settings are canceled.
  - White balance
  - Iris
  - Shutter speed
  - ISO/gain
- When [SCENE SELECTION ] is set, [ FOCUS AREA ] is fixed to [ WIDE].

#### Hint

- You can assign this function to the ASSIGN button.





---

#### Related Topic

- [AUTO MODE SET](#)
- [FOCUS AREA](#)
- [Assigning the functions to the ASSIGN buttons](#)

## SPOT METER/FOCUS



You can automatically adjust the brightness and focus for the subject touched on the screen.

- 1 Set the AUTO/MANUAL switch to MANUAL, and press the AF/MF button to set the focus mode to manual (MF).  
 appears.
- 2 MENU button -  (CAMERA SET) - [SPOT METER/FOCUS].
- 3 Touch the LCD monitor to select the subject.
  - The brightness and focus for the selected subject are adjusted automatically.
  -  next to the iris, ISO/gain, and shutter speed value turns to .

### Note

- [SPOT METER/FOCUS] is available only with manual focus.

### Hint

- If you press the SET button,  next to the iris, ISO/gain, and shutter speed value returns to .
- Automatic brightness adjustment can be canceled by setting the AUTO/MANUAL switch to AUTO.
- You can assign this function to the ASSIGN button.

### Related Topic



- [Parts and controls \(right back side/back\)](#)
- [Assigning the functions to the ASSIGN buttons](#)





## SPOT METER

---

You can adjust the brightness for the selected subject automatically .

- 1 Set the AUTO/MANUAL switch to MANUAL.
- 2 MENU button -  (CAMERA SET) - [ SPOT METER].
- 3 Touch the LCD monitor to select the subject.
  - The brightness for the selected subject is adjusted automatically .
  -  next to the iris, ISO/gain, and shutter speed value turns to .

### Hint

- If you press the SET button,  next to the iris, ISO/gain, and shutter speed value returns to .
- Automatic brightness adjustment can be canceled by setting the AUTO/MANUAL switch to AUTO.
- You can assign this function to the ASSIGN button.

---

### Related Topic



- [Parts and controls \(right back side/back\)](#)
- [Assigning the functions to the ASSIGN buttons](#)

Digital 4K Video Camera Recorder  
FDR-AX700

## SPOT FOCUS

---

You can automatically adjust the focus for the selected subject.

- 1 Set the AUTO/MANUAL switch to MANUAL, and press the AF/MF button to set the focus mode to manual (MF).
  -  appears.
- 2 MENU button -  (CAMERA SET) - [SPOT FOCUS].
- 3 Touch the LCD monitor to select the subject.
  - The focus for the selected subject is adjusted automatically .

### Note

- [SPOT FOCUS] is available only with manual focus.

### Hint

- You can assign this function to the ASSIGN button.

---

### Related Topic

- [Parts and controls \(right back side/back\)](#)
- [Assigning the functions to the ASSIGN buttons](#)

Digital 4K Video Camera Recorder  
FDR-AX700

## LOW LUX

---

You can shoot bright color images, even in dim light, by adjusting the gain and shutter speed automatically (Movie mode only).

- 1 MENU button -  (CAMERA SET) - [LOW LUX].

### Descriptions of menu items

OFF:

Does not use the Low Lux function.

ON:

Uses the Low Lux function.

#### Hint

- This setting is available only when **AUT** /MANUAL switch is set to **AUT** and [AUTO MODE SET] is set to [AUTO].
- You can assign this function to the ASSIGN button.

---

### Related Topic

- [Assigning the functions to the ASSIGN buttons](#)

Digital 4K Video Camera Recorder  
FDR-AX700

## AUTO BACK LIGHT

---

You can automatically perform backlight correction (Movie mode only).

- 1 MENU button -  (CAMERA SET) - [AUTO BACK LIGHT].

### Descriptions of menu items

OFF:

Does not perform backlight correction automatically.

ON:

Automatically performs backlight correction.

#### Note

- [AUTO BACK LIGHT] is set to [ON] in the following situation.
  - When [AUTO MODE SET] is set to [INTELLIGENT AUTO].
  - When [AUTO MODE SET] is set to [SCENE SELECTION] and [FIREWORKS] is selected for [SCENE SELECTION].
- [AUTO BACK LIGHT] is not available in the following situation.
  - When recording with [HIGH FRAME RATE] in [S&Q MOTION] set to [ON].
  - When recording with SUPER SLOW MOTION.
  - When 120p/100p setting is selected in [REC FORMAT].
  - When [GAMMA] in [PICTURE PROFILE] is set to either of [HLG], [HLG1], [HLG2], [HLG3].

Digital 4K Video Camera Recorder  
FDR-AX700

## NIGHTSHOT

---

You can set the NIGHTSHOT function (Movie mode only). The screen turns green when [ NIGHTSHOT ] is selected. When [ NIGHTSHOT LIGHT ] is set to [ OFF ], the infrared light does not emit even if [ NIGHTSHOT ] is set to [ ON ].

- 1 MENU button -  (CAMERA SET) - [ NIGHTSHOT ].

### Descriptions of menu items

OFF:

Disables the NIGHTSHOT function.

ON:

Enables the NIGHTSHOT function.

#### Note

- This setting is available only when the AUTO/MANUAL switch is set to AUTO.
- Make sure that your finger does not cover the NIGHTSHOT light emitter when shooting.
- Remove the lens hood so that it does not block the infrared light emitter.
- The light is effective up to a distance of approximately 3 meters.

#### Hint

- You can assign this function to the ASSIGN button.

---

### Related Topic

- [Parts and controls \(left front side/front\)](#)
- [NIGHTSHOT LIGHT](#)
- [Assigning the functions to the ASSIGN buttons](#)

Digital 4K Video Camera Recorder  
FDR-AX700

## NIGHTSHOT LIGHT

---

When shooting with NIGHTSHOT, infrared light is emitted from the NIGHTSHOT light emitter (Movie mode only). You can shoot clear images.

The infrared light does not turn on when [ NIGHTSHOT LIGHT] is set to [ OFF].

- 1 MENU button -  (CAMERA SET) - [ NIGHTSHOT LIGHT].

### Descriptions of menu items

ON:

Emits the infrared light.

OFF:

Does not emit the infrared light.

#### Note

- Make sure that your finger does not cover the NIGHTSHOT light emitter when shooting.
- Remove the lens hood so that it does not block the NIGHTSHOT light emitter.
- The light is effective up to a distance of approximately 3 meters.
- When [FILE FORMAT] is set to [ XAVC S 4K] and [ 4K REC OUTPUT] is set to [ EXTERNAL OUTPUT], [ NIGHTSHOT LIGHT] is fixed to [ OFF].

---

### Related Topic

- [Parts and controls \(left front side/front\)](#)
- [NIGHTSHOT](#)

## COLOR BAR

---

You can set the color bar display (Movie mode only).

This function helps you to adjust colors when you view movies recorded with the camcorder on a TV or a monitor .

- 1 MENU button -  (CAMERA SET) - [ COLOR BAR ] – select the desired item.

### Descriptions of menu items

#### ON/OFF:

Sets the color bar display to on/off.

- OFF: Does not display color bars.
- ON: Displays color bars.

#### TONE:

Sets whether to output audio tone signals during displaying color bars.

- OFF: Does not output audio tone signals.
- ON: Outputs audio tone signals.

#### Note

- This setting is disabled in the following situations:
  - When [FILE FORMAT] is set to [ XAVC S 4K].
  - When 120p/100p is selected for [ REC FORMAT].
  - When [PROXY REC MODE] is set to [ ON].
  - During recording with S&Q MOTION.
  - During recording with SUPER SLOW MOTION.
- [ON/OFF] is automatically set to [ OFF] when you change the recording format, perform the function  on the menu, or turn the camcorder off.
- You cannot change the [ COLOR BAR] setting during recording or focus magnification operation (FOCUS MAGNIFIER).

#### Hint

- The gamma curve equivalent to ITU709 is applied while color bars are displayed.
- If you record color bars with [ TONE] set to [ OFF], the camcorder records sound from the microphone.
- Audio tone signals are output in “1 kHz: full bit -10 dB.”
- You can assign this function to the ASSIGN button.

---

### Related Topic

- [Assigning the functions to the ASSIGN buttons](#)

Digital 4K Video Camera Recorder  
FDR-AX700

## PICTURE PROFILE

---

You can customize the picture quality by adjusting picture profile items, such as [ **GAMMA**] and [ **DETAIL**] (Movie mode only).

Picture quality settings for different recording conditions have been stored in **PP1** through **PP10** (picture profile1 through 10) as default settings. You can select the desired picture profile and perform shooting with the settings of the selected picture profile.

You can also change the settings of picture profile.

For details, see “ [Changing the picture profile](#) .”

### Descriptions of menu items

OFF:

Does not use the picture profile.

PP1 – PP10:

Select the picture profile.

#### Hint

- You can assign this function to the ASSIGN button.

---

### Related Topic

- [Changing the picture profile](#)
- [Assigning the functions to the ASSIGN buttons](#)







Digital 4K Video Camera Recorder  
FDR-AX700

## SHOOTING MODE

---

You can switch the shooting mode between Movie mode and Photo mode.  
The icon of the selected shooting mode appears on the LCD monitor .

- : Movie mode
- : Photo mode

① MENU button -  (REC/OUT SET) - [/ SHOOTING MODE].

### Descriptions of menu items

#### MOVIE:

Shoots movies.

#### PHOTO:

Shoots photos.

#### Hint

- You can assign this function to the ASSIGN button.

---

### Related Topic

- [Recording movies](#)
- [Shooting photos](#)
- [Screen indicators](#)
- [Assigning the functions to the ASSIGN buttons](#)

Digital 4K Video Camera Recorder  
FDR-AX700

## REC SET

You can set the file format, recording format, simultaneous recording, and relay recording for movie recording.

- 1 MENU button -  (REC/OUT SET) - [REC SET] – select the desired item.

### Descriptions of menu items

#### FILE FORMAT:

Sets the file format for recording.

- XAVC S 4K: Records 4K images in XA VC S format.  
This setting is suitable for watching on a 4K TV . Both formats for recording and playback are set to this format. Movies you can play are also changed depending on the frame rate setting.
- XAVC S HD: Records HD (high definition) images in XA VC S format.  
This setting is suitable for watching on an HD (high definition) TV . Both formats for recording and playback are set to this format.
- AVCHD: Records HD (high definition) images in A VCHD format.  
This setting is suitable for watching on an HD (high definition) TV and Blu-ray disc recording. Both of formats for recording and playback are set to this format.

#### REC FORMAT:

Sets the recording format (bit-rate, image size, frame rate, scanning system) during recording.

The setting items differ depending on the setting of  (OTHERS) - [60i/50i SEL].

When selecting [ 60i]:

- When selecting [ XAVC S 4K] on [ FILE FORMAT]  
2160/30p 100Mbps, 2160/30p 60Mbps, 2160/24p 100Mbps, 2160/24p 60Mbps
- When selecting [ XAVC S HD] on [ FILE FORMAT]  
1080/120p 100Mbps, 1080/120p 60Mbps, 1080/60p 50Mbps, 1080/60p 25Mbps, 1080/30p 50Mbps, 1080/30p 16Mbps, 1080/24p 50Mbps
- When selecting [ AVCHD] on [ FILE FORMAT]  
1080/60i FX, 1080/60i FH, 1080/60i LP

When selecting [ 50i]:

- When selecting [ XAVC S 4K] on [ FILE FORMAT]  
2160/25p 100Mbps, 2160/25p 60Mbps
- When selecting [ XAVC S HD] on [ FILE FORMAT]  
1080/100p 100Mbps, 1080/100p 60Mbps, 1080/50p 50Mbps, 1080/50p 25Mbps, 1080/25p 50Mbps, 1080/25p 16Mbps
- When selecting [ AVCHD] on [ FILE FORMAT]

**SIMUL/RELAY REC:**

Performs the settings of the simultaneous and relay recording.

- OFF: Does not perform the simultaneous and relay recording.
- SIMULTANEOUS REC: Performs the simultaneous recording.  
You can record movies on both memory card A and memory card B simultaneously.
- RELAY REC: Performs the relay recording.  
By inserting memory cards in slots A and B, the camcorder automatically switches memory cards just before space on the other one runs out, and continues recording.

**PROXY REC MODE:**

Sets whether to record MP4 movies simultaneously when recording movies in XAVC S 4K or XAVC S HD format. MP4 movies are useful for uploading to video-sharing site or using for video editing.

- ON/OFF: Records MP4 movies simultaneously when setting to [ ON].
- SIZE: Select the image size (1280×720 or 640×360).

**About the setting values of [REC FORMAT]**

The setting values of [ REC FORMAT] indicate bit-rate, image size, frame rate, and scanning system.

- Bit-rate: 100Mbps, 60Mbps, 50Mbps, 25Mbps, 16Mbps, FX (max. 24 Mbps), FH (approx. 17 Mbps (average)), LP (approx. 5 Mbps (average))
- Image size: 2160 (3,840 × 2,160), 1080 (1,920 × 1,080)
- Frame rate: Either 120, 100, 60, 50, 30, 25, or 24
- Scanning system: i (interlace), p (progressive)

**About the frame rate indication**

The frame rate displayed on the LCD monitor differs from the actual frame rate.

Frame rate on the LCD monitor	Actual frame rate
24	23.98
30	29.97
60	59.94
120	119.88

**Note**

- Proxy recording is disabled in the following situations:
  - [DATE REC] is set to [ ON].
  - [COLOR BAR] is set to [ ON].
  - [SIMUL/RELAY REC] is set to [SIMULTANEOUS REC] or [RELAY REC] and [EXTERNAL OUTPUT] is selected in [VIDEO OUT] - [OUTPUT SELECT] - [4K REC OUTPUT].
  - 120p/100p is selected in [ REC FORMAT].
- [PROXY REC MODE] is automatically set to [ OFF] during recording with [ S&Q MOTION] or [ SUPER SLOW MOTION].
- The Proxy recording is not available when recording in AVCHD format.
- Proxy files cannot be played on the camcorder. Use or view them after copying them to the computer.

---

---

## Related Topic

- [Recording with Slow & Quick Motion](#)
- [Recording with Super Slow Motion](#)
- [Continuing recording on the memory cards one after another \(Relay recording\)](#)
- [Recording movies on both the memory card A and B \(Simultaneous recording\)](#)
- [Import and utilize images on your computer \( \[PlayMemories Home\]\(#\) \)](#)
- [60i/50i SEL](#)

4-725-312-11(2) Copyright 2017 Sony Corporation

## IMAGE SIZE

---

You can select a size for the photos. The expected number of recordable photos differs depending on this setting.

- 1 MENU button -  (REC/OUT SET) - [IMAGE SIZE].

### Descriptions of menu items

#### 3:2(12.0M):

Aspect ratio 3:2 (suitable for standard prints), effective pixels in Photo mode: Approx. 12.00 mega pixels

#### 16:9(14.2M):

Aspect ratio 16:9 (for viewing on a high-definition TV), effective pixels in Photo mode: Approx. 14.20 mega pixels

---

### Related Topic

- [Shooting photos](#)

Digital 4K Video Camera Recorder  
FDR-AX700

## FILE NUMBER

---

You can select how to assign file numbers to recorded photos.

- 1 MENU button -  (REC/OUT SET) - [FILE NUMBER].

### Descriptions of menu items

#### SERIES:

Assigns file numbers of photos in sequence.

The file number becomes larger each time you shoot a photo.

Even if the memory card is replaced with another one, the file number is assigned in sequence.

#### RESET:

Assigns file numbers in sequence, following the largest file number existing on the memory card.

When the memory card is replaced with another one, the file number is assigned for each memory card.

---

### Related Topic

- [Shooting photos](#)

Digital 4K Video Camera Recorder  
FDR-AX700

## VIDEO OUT

You can set the output destination or output method of pictures.

- 1 MENU button -  (REC/OUT SET) - [VIDEO OUT] – select the desired item.

### Descriptions of menu items

#### OUTPUT SELECT:

##### 4K REC OUTPUT:

Outputs picture signals during recording in XA VC S 4K format to either of the camcorder's viewfinder/LCD monitor or an external device.

You can use the face detection function during 4K recording.

- VF/LCD PANEL: Outputs to the viewfinder/LCD monitor .
- EXTERNAL OUTPUT: Outputs to the external devices.

#### HDMI:

You can select the resolution of the output signal from the HDMI OUT terminal.

The setting items differ depending on the setting of  (OTHERS) - [60i/50i SEL].

When selecting [ 60i]:

AUTO, 2160p/1080p/480i, 2160p/720p/480i, 2160p/1080i/480i, 1080p/480i, 720p/480i, 1080i/480i, 480p, 480i

When selecting [ 50i]:

AUTO, 2160p/1080p/576i, 2160p/720p/576i, 2160p/1080i/576i, 1080p/576i, 720p/576i, 1080i/576i, 576p, 576i

24p OUTPUT (when 60i is selected for [ 60i/50i SEL ] only):

You can set the output format when the frame rate setting of [ REC FORMAT] is 24p.

- 24p: Outputs in 24p.
- 60p: Outputs in 60p.

#### DOWN CONVERT TYPE:

You can set the picture output method.

Use this function for outputting movies or photos recorded in 16:9.

- SQUEEZE: Outputs a horizontally compressed image while maintaining its original height.
- LETTER BOX(16:9): Outputs a vertically compressed image while maintaining its original aspect ratio.
- EDGE CROP: Outputs the central portion of the original image by cropping its right and left edges.

#### HDMI TC OUTPUT:

You can set whether to output time code to other devices via HDMI.

- OFF: Does not overlap the time code information on HDMI output signal.
- ON: Overlaps the time code information on HDMI output signal.  
The data is transmitted as digital data, not as a projected image, and the connected device identifies the time data by referencing the transmitted digital data.



If the frame rate is 24p, 2-3 pulldown is performed and the converted information is automatically added and transmitted.

#### HDMI REC CONTROL:

When the camcorder is connected to an external recorder, the recording start/stop operation of the external recorder is controlled by the camcorder's operation.

- OFF: Does not start recording on an external recorder by the camcorder's operations.
- ON: Starts recording on an external recorder by the camcorder's operations.

#### Note

- The [4K REC OUTPUT] setting is enabled only when  (REC/OUT SET) - [REC SET] - [FILE FORMAT] is set to [XAVC S 4K].
- You can use one of the following functions during recording in XAVC S 4K format.
  - Outputting signals to an external device during recording
  - FACE DETECTION function
  - Proxy recording (not available when satisfying all the following conditions)
    -  (REC/OUT SET) - [REC SET] - [REC FORMAT] is set to 100Mbps.
    -  (REC/OUT SET) - [REC SET] - [SIMUL/RELAY REC] is set to other than [OFF].

---

#### Related Topic

- [REC SET](#)
- [60i/50i SEL](#)
- [Viewing images on a 4K TV](#)
- [Viewing images on a high definition TV](#)
- [On the HDMI cable](#)





Digital 4K Video Camera Recorder  
FDR-AX700

## VOLUME

---

You can adjust the volume.

- 1 MENU button -  (AUDIO SET) - [VOLUME].
  - Adjust the volume with  /  .

### Hint

- You can assign this function to the ASSIGN button.

---

### Related Topic

- [Assigning the functions to the ASSIGN buttons](#)

Digital 4K Video Camera Recorder  
FDR-AX700

## AVCHD AUDIO FORMAT

---

You can set the audio format for AVCHD recording.

- 1 MENU button -  (AUDIO SET) - [AVCHD AUDIO FORMAT].

### Descriptions of menu items

#### LINEAR PCM:

Records audio in LPCM format.

#### DOLBY DIGITAL:

Records audio in Dolby Digital format.

Digital 4K Video Camera Recorder  
FDR-AX700

## AUDIO REC LEVEL

---

You can set the recording level of the audio input for the camcorder's internal microphone or external microphone (sold separately).

- 1 MENU button -  (AUDIO SET) - [AUDIO REC LEVEL] - select the desired item.

### Descriptions of menu items

#### REC LEVEL MODE :

Sets the recording mode.

- AUTO: Adjusts the recording level automatically .
- MANUAL: Sets the recording sensitivity between 1 and 31 at [ MANUAL REC LEVEL ].

#### MANUAL REC LEVEL :

Sets the recording sensitivity when [ REC LEVEL MODE ] is set to [ MANUAL ].

1 – 31: Select the recording sensitivity .

#### Note

- It is recommended that you wear headphones to operate while checking the level.
- When continuously recording loud sound, lower the recording level to record the sound with high presence.
- The limiter is always active regardless of the setting value of the recording level.
- When you are using a dedicated microphone that is connected with the Multi interface shoe, the recording level setting will be invalid, and you will not be able to adjust the recording level.

---

### Related Topic

- [Recording audio with the internal microphone](#)
- [Recording audio with a Multi interface shoe compatible microphone \(sold separately\)](#)
- [Recording audio with an external microphone \(sold separately\)](#)

Digital 4K Video Camera Recorder  
FDR-AX700

## INT MIC WIND

---

You can diminish low tone in input sound with the internal microphone, and reduce wind noise.

- 1 MENU button -  (AUDIO SET) - [INT MIC WIND].

### Descriptions of menu items

OFF:

Disables wind noise reduction.

ON:

Enables wind noise reduction.

Digital 4K Video Camera Recorder  
FDR-AX700

## MIC SELECT

---

You can select the microphone to use for recording audio.

- 1 MENU button -  (AUDIO SET) - [MIC SELECT].

### Descriptions of menu items

#### AUTO:

Selects the microphone used for recording audio automatically based on the microphone that is connected.

The microphone is selected in the following order of priority .

External microphone connected to MIC jack (PLUG IN POWER) - Multi interface shoe compatible microphone -

Internal microphone

#### INT MIC:

Uses the camcorder 's internal microphone to record audio.

#### MI SHOE MIC:

Uses a Multi interface shoe compatible microphone to record audio.

#### STEREO MINI MIC:

Uses a microphone connected to the MIC jack (PLUG IN POWER) to record audio.

---

### Related Topic

- [Recording audio with the internal microphone](#)
- [Recording audio with a Multi interface shoe compatible microphone \(sold separately\)](#)
- [Recording audio with an external microphone \(sold separately\)](#)

Digital 4K Video Camera Recorder  
FDR-AX700

## AUDIO OUTPUT TIMING

---

You can set the timing of the audio output when recording.

- 1 MENU button -  (AUDIO SET) - [AUDIO OUTPUT TIMING].

### Descriptions of menu items

LIVE:

Outputs audio without any delay during recording.

LIP SYNC:

Outputs audio synchronized with movie that is output during recording.

#### Note

- Select [LIP SYNC] when recording to an external device via the HDMI.

---

### Related Topic

- [Viewing images on a 4K TV](#)
- [Viewing images on a high definition TV](#)

Digital 4K Video Camera Recorder  
FDR-AX700

## HISTOGRAM

---

You can set the histogram display that indicates level distributions of images.

- 1 MENU button -  (DISPLAY SET) - [HISTOGRAM].

### Descriptions of menu items

OFF:

Does not display the histogram.

ON:

Displays the histogram.

A line appears at the 100% position, and the background color of the zone above the line changes.



A: Histogram

ON[ZEBRA POINT]:

Shows the point where the zebra pattern appears in the histogram.

A line is displayed at the brightness level set on [ ZEBRA].

#### Hint

- You can assign this function to the ASSIGN button.

---

#### Related Topic

- [ZEBRA](#)
- [Assigning the functions to the ASSIGN buttons](#)

Digital 4K Video Camera Recorder  
FDR-AX700

## ZEBRA

---

You can set the zebra function.

The zebra is a stripe pattern that appears in areas of brightness equal to or exceeding the brightness level you set.

It is useful for adjusting brightness as a guide.

- 1 MENU button -  (DISPLAY SET) - [ZEBRA] – select the desired item.

### Descriptions of menu items

#### ZEBRA SELECT :

Selects the type of zebra display ( ZEBRA1 or ZEBRA2).

- OFF: Does not display the zebra patterns.
- ZEBRA1: Displays the zebra patterns in the areas of brightness that are set on [ ZEBRA1 LEVEL ] within the range set on [ ZEBRA1 APERTURE LEVEL].
- ZEBRA2: Displays the zebra patterns for a brightness level higher than that set on [ ZEBRA2 LEVEL ].

#### ZEBRA1 LEVEL :

Sets the brightness level for [ ZEBRA1].

0% - 109%: Select the brightness level.

#### ZEBRA1 APERTURE LEVEL:

Sets the range of brightness for the level that is set on [ ZEBRA1 LEVEL ].

2% - 20%: Select the range.

#### ZEBRA2 LEVEL :

Sets the brightness level for [ ZEBRA2].

0% - 109%: Select the brightness level.

#### Hint

- You can assign this function to the ASSIGN button.

---

### Related Topic

- [Assigning the functions to the ASSIGN buttons](#)



Digital 4K Video Camera Recorder  
FDR-AX700

## PEAKING

---

You can set the peaking display (enhances outlines of an image on the LCD monitor).  
You can focus more easily using this function in combination with the focus magnifier function (FOCUS MAGNIFIER).

- 1 MENU button -  (DISPLAY SET) - [PEAKING] – select the desired item.

### Descriptions of menu items

#### ON/OFF:

Sets the peaking display to on/off.

- OFF: Does not display the peaking.
- ON: Displays an image on the LCD monitor with its outlines enhanced.  
This function helps you to adjust the focus.

#### COLOR:

Select peaking color .  
WHITE, RED, YELLOW

#### LEVEL:

Select a peaking sensitivity .  
HIGH, MIDDLE, LOW

#### Note

- The enhanced outlines are not recorded on the memory card.

#### Hint

- You can assign [ON/OFF ] of this function to the ASSIGN button.

---

### Related Topic

- [Focusing by magnifying an image \( FOCUS MAGNIFIER\)](#)
- [Assigning the functions to the ASSIGN buttons](#)

Digital 4K Video Camera Recorder  
FDR-AX700

## PHASE AF FRAMES

---

You can set whether to display the phase detection AF frames when selecting [ WIDE] or [ ZONE] on [ FOCUS AREA] while recording movies with auto focus.

- 1 MENU button-  (DISPLAY SET) - [PHASE AF FRAMES].

### Descriptions of menu items

ON:

Displays the phase detection AF frames.

OFF:

Does not display the phase detection AF frames.

#### Note

- When the camcorder is in focus, the focus frame lights in green if [FOCUS AREA ] is set to the following.
  - [CENTER]
  - [FLEXIBLE SPOT ]
- The phase AF detection frames are not displayed when [ DATE REC] is set to [ ON].

#### Hint

- You can assign this function to the ASSIGN button.

---

### Related Topic

- [Adjusting the focus automatically](#)
- [Phase detection AF](#)
- [Assigning the functions to the ASSIGN buttons](#)

Digital 4K Video Camera Recorder  
FDR-AX700

## PHASE DETECT. AF AREA

---

You can set whether to display the phase detection AF area during auto focus.

- 1 MENU button -  (DISPLAY SET) - [PHASE DETECT. AF AREA].

### Descriptions of menu items

ON:

Displays the phase detection AF area.

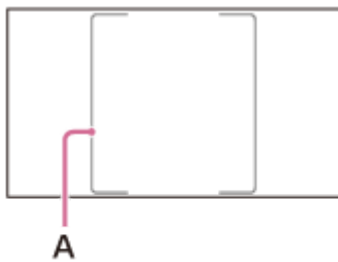

A: Phase detection AF area

OFF:

Does not display the phase detection AF area.

#### Note

- The phase detection AF area is not displayed when the phase detection AF is not effective.

---

### Related Topic

- [Adjusting the focus automatically](#)
- [Phase detection AF](#)

Digital 4K Video Camera Recorder  
FDR-AX700

## MARKER

You can set the marker display that is used for a shooting guide on the LCD monitor .

- 1 MENU button -  (DISPLAY SET) - [MARKER] – select the desired item.

### Descriptions of menu items

#### ON/OFF:

Sets the marker display to on/off.

- OFF: Does not display the marker .
- ON : Displays the marker .  
The marker is not recorded on a memory card.

#### CENTER:

Sets the center marker (indicates center of the LCD monitor) display to on/off.

- ON: Displays the center marker .
- OFF: Does not display the center marker .



#### ASPECT:

Sets the aspect marker display to on/off.

- OFF: Does not display the aspect marker .
- 4:3, 13:9, 14:9, 15:9, 1.66 : 1, 1.85 : 1, 2.35 : 1: Displays markers at boundaries of display area defined by the aspect ratio.



#### SAFETY ZONE:

Sets the safety zone marker to on/off.

- OFF: Does not display the safety zone marker .
- 80%, 90%: Displays markers at the boundaries of the display area that regular home TVs can display .



#### GUIDEFAME:

Sets the guide frame to on/off.

- OFF: Does not display the guide frame.
- ON: Displays the guide frame.

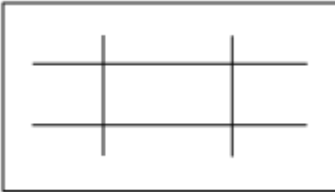

#### Note

- Only the time code is output when [MARKER ] is set to [ ON], even if [ DISPLAY OUTPUT] is set to [ ALL OUTPUT].
- You cannot display markers while using the FOCUS MAGNIFIER function.
- You cannot output markers to an external device.

#### Hint

- You can display all types of markers at the same time.
- You can obtain a balanced composition by positioning the subject at the cross points of the guide frame.
- You can assign [ON/OFF ] of this function to the ASSIGN button.

---

#### Related Topic

- [Focusing by magnifying an image \( FOCUS MAGNIFIER\)](#)
- [Assigning the functions to the ASSIGN buttons](#)
- [DISPLAY OUTPUT](#)

Digital 4K Video Camera Recorder  
FDR-AX700

## FOCUS MAG RATIO

---

You can set the magnification ratio of the focus magnification function (FOCUS MAGNIFIER).

1 MENU -  (DISPLAY SET) - [FOCUS MAG RATIO].

### Descriptions of menu items

x4.0:  
4 times

x8.0 :  
8 times

x4.0/x8.0:  
The setting changes in the order of [ x4.0] - [x8.0] - [OFF] with each press of the FOCUS MAGNIFIER button.

---

### Related Topic

- [Focusing by magnifying an image \( FOCUS MAGNIFIER\)](#)

## CAMERA DATA DISPLAY

You can set the display of the iris, ISO/gain, and shutter speed settings.

- 1 MENU button -  (DISPLAY SET) - [CAMERA DATA DISPLAY].

### Descriptions of menu items

OFF:

Does not display the iris, ISO/gain, and shutter speed settings.

ON:

Constantly displays the iris, ISO/gain, and shutter speed settings.

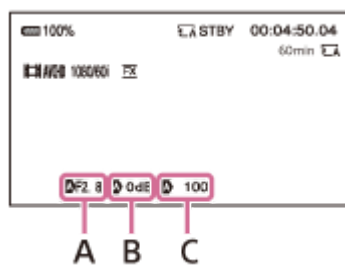

A: Iris value

B: Gain value (or ISO value)

C: Shutter speed value

### Hint

- The settings appear during the manual adjustment regardless of the settings of this function.
- **A** indicates that the settings are automatically adjusted values.
- **E** appears when exposure is fixed by [SPOT METER] or [ SPOT METER/FOCUS].
- The displayed value is different from the [ CAMERA DATA] setting in [DA TA CODE].
- You can assign this function to the ASSIGN button.

### Related Topic

- [SPOT METER/FOCUS](#)
- [SPOT METER](#)
- [DATA CODE](#)
- [Assigning the functions to the ASSIGN buttons](#)

## AUDIO LEVEL DISPLAY

---

You can set the audio level meter display (Movie mode only).

- 1 MENU button -  (DISPLAY SET) - [AUDIO LEVEL DISPLAY].

### Descriptions of menu items

ON:

Displays the audio level meters.

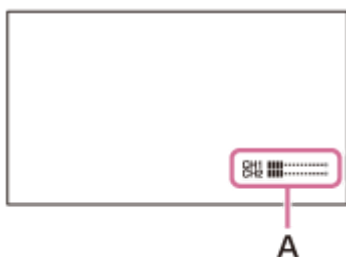

A: Audio level meters

OFF:

Does not display the audio level meters.

#### Hint

- You can assign this function to the ASSIGN button.

---

### Related Topic

- [Assigning the functions to the ASSIGN buttons](#)



Digital 4K Video Camera Recorder  
FDR-AX700

## ZOOM DISPLAY

---

You can set the display of the zoom position.

- 1 MENU button -  (DISPLAY SET) - [ZOOM DISPLAY].

### Descriptions of menu items

#### BAR:

Displays a bar that indicates the zoom position.

#### NUMBER:

Displays a number that indicates the zoom position.

---

### Related Topic

- [Adjusting the zoom with the zoom lever](#)
- [Adjusting the zoom with the manual lens ring](#)

Digital 4K Video Camera Recorder  
FDR-AX700

## FOCUS DISPLAY

---

You can set the unit for the focal length.

- 1 MENU button -  (DISPLAY SET) - [FOCUS DISPLAY].

### Descriptions of menu items

#### METER:

Displays the focal length in meters.

#### FEET:

Displays the focal length in feet.

Digital 4K Video Camera Recorder  
FDR-AX700

## SHUTTER DISPLAY

You can set the shutter speed display (Movie mode only).

- 1 MENU button -  (DISPLAY SET) - [SHUTTER DISPLAY].

### Descriptions of menu items

#### SECOND:

Displays the shutter display in seconds.

#### DEGREE:

Displays the shutter display in degrees.

The shutter speed equal to the period that your camcorder reads image data from the image sensor is defined as 360 degrees. The degree is calculated based on this definition and displayed.

The setting items differ depending on the setting of  (OTHERS) - [60i/50i SEL].

When selecting [ 60i]:

- When selecting the setting value of [ REC FORMAT] whose frame rate value is 60, the shutter angle is 360 degrees when the shutter speed is 1/60.
- When selecting the setting value of [ REC FORMAT] whose frame rate value is 30, the shutter angle is 360 degrees when the shutter speed is 1/30.
- When selecting the setting value of [ REC FORMAT] whose frame rate value is 24, the shutter angle is 360 degrees when the shutter speed is 1/24.

When selecting [ 50i]:

- When selecting the setting value of [ REC FORMAT] whose frame rate value is 50, the shutter angle is 360 degrees when the shutter speed is 1/50.
- When selecting the setting value of [ REC FORMAT] whose frame rate value is 25, the shutter angle is 360 degrees when the shutter speed is 1/25.

#### Note

- When you press the ASSIGN button to which [ DATA CODE] is assigned, the shutter speed is displayed in seconds regardless of this setting.

#### Hint

- If the shutter speed is more than 360 degrees, it is displayed as an integral multiple of 360 degrees (360°x2, etc.).

### Related Topic

- [Adjusting the shutter speed](#)
- [REC SET](#)
- [DATA CODE](#)
- [60i/50i SEL](#)



Digital 4K Video Camera Recorder  
FDR-AX700

## DATA CODE

---

You can select the information that is displayed during playback.

- 1 Press the MENU button while playing back movies -  (DISPLAY SET) - [DATA CODE].

### Descriptions of menu items

OFF:

Does not display the information.

DATE/TIME:

Displays the date and time.

CAMERA DATA:

Displays camera data.

#### Hint

- You can assign this function to the ASSIGN button.

---

### Related Topic

- [CAMERA DATA DISPLAY](#)
- [Displaying recording data \( DATA CODE\)](#)
- [Assigning the functions to the ASSIGN buttons](#)

Digital 4K Video Camera Recorder  
FDR-AX700

## GAMMA DISP ASSIST

When shooting or playing the movies with S-LOG or HLG applied, you can convert movie images displayed on the viewfinder or LCD monitor to a movie with normal image quality (Movie mode only).

- 1 MENU button -  (DISPLAY SET) - [GAMMA DISP ASSIST] – select the desired item.

### Descriptions of menu items

#### ON/OFF:

Sets the gamma display assist function to on/off.

- ON: Use the gamma display assist function.
- OFF: Does not use the gamma display assist function.

#### TYPE:

Sets the convert type.

- AUTO: Displays movies with gamma or color mode set in [ PICTURE PROFILE] after converting to the following.
  - Gamma [S-LOG2] to [ S-LOG2→709(800%)]
  - Gamma [S-LOG3] to [ S-LOG3→709(800%)]
  - Gamma [HLG], [ HLG1], [HLG2], [HLG3] and color mode [ 709] to [ HLG(709)]
  - Gamma [HLG], [ HLG1], [HLG2], [HLG3] and color mode [ BT.2020] to [ HLG(BT.2020)]
- S-LOG2→709(800%): Displays movies after converting S-LOG2 gamma to the gamma equivalent to ITU709(800%).
- S-LOG3→709(800%): Displays movies after converting S-LOG3 gamma to the gamma equivalent to ITU709(800%).
- HLG(709): Displays movies after adjusting the image quality of the camcorder's LCD panel or viewfinder to a quality that is almost the same as when movies are displayed on an HLG(709) compatible monitor .
- HLG(BT.2020): Displays movies after adjusting the image quality of the camcorder's LCD panel or viewfinder to a quality that is almost the same as when movies are displayed on an HLG(BT.2020) compatible monitor .

### About the gamma display assist function

Movie images applied with [ S-LOG2] or [ S-LOG3] have low contrast because they are assumed to be processed after recording.

Also, movie images applied with [ HLG], [HLG1], [HLG2] or [ HLG3] are displayed in low contrast if the images are displayed in a finder or LCD monitor which does not support HDR, and movie images with the [ BT.2020] color mode setting are displayed in faint color . Either of the images are therefore difficult to monitor as it is.

Using [ GAMMA DISP ASSIST], an image contrast equivalent to that of movies recorded normally can be reproduced on the LCD monitor or viewfinder of the camcorder , and this makes it easy to monitor the image.

#### Note

- When setting to [ AUTO] during playback, images of the A VCHD and XAVC S movies other than those recorded with [HLG] are displayed based on the current gamma setting and color mode setting in [ PICTURE PROFILE].

#### Hint

- You can assign this function to the ASSIGN button.

---

---

## Related Topic

- [PICTURE PROFILE](#)
- [Assigning the functions to the ASSIGN buttons](#)

4-725-312-11(2) Copyright 2017 Sony Corporation

Digital 4K Video Camera Recorder  
FDR-AX700

## LCD BRIGHT

---

You can adjust the brightness of the LCD monitor . Changes in the LCD brightness do not affect the brightness of recording images.

1 MENU button -  (DISPLAY SET) - [LCD BRIGHT].

### Descriptions of menu items

#### NORMAL:

Displays in normal brightness.

#### BRIGHT:

Displays brightly .





Digital 4K Video Camera Recorder  
FDR-AX700

## VF COLOR TEMP.

---

You can adjust the color temperature of the viewfinder .  
Low color temperature makes the viewfinder appear reddish, and high color temperature makes it appear bluish.

1 MENU button -  (DISPLAY SET) - [VF COLOR TEMP.].

- Adjust the color temperature of the viewfinder with  /  .

Digital 4K Video Camera Recorder  
FDR-AX700

## DISPLAY OUTPUT

---

You can select where to output the display information, such as time code.

- 1 MENU button -  (DISPLAY SET) - [DISPLAY OUTPUT].

### Descriptions of menu items

#### LCD PANEL:

Outputs the information to the LCD monitor .

#### ALL OUTPUT :

Outputs information to the HDMI OUT terminal, VIDEO OUT jack (Multi/Micro USB T terminal), and the LCD monitor .

Zebra, peaking, and the face detection frame are also output.

#### Note

- Only the time code, zebra, peaking, and the face detection frame are output when [MARKER ] is set to [ ON] and a marker is displayed on the LCD monitor .
- Nothing is displayed on the LCD monitor in the following cases.
  - The LCD monitor is rotated 180 degrees.
  - The eye sensor detects something nearby and the camcorder switches to viewfinder view .

---

### Related Topic

- [MARKER](#)
- [TC/UB DISPLAY](#)
- [ZEBRA](#)
- [PEAKING](#)
- [Focusing on a detected face \( FACE DETECTION\)](#)

Digital 4K Video Camera Recorder  
FDR-AX700

## TC/UB DISPLAY

---

The camcorder records time data, such as the time code and user bit, as the data associated with the movie. You can select whether to display the time code or the user bit (Movie mode only).

- 1 MENU button -  (TC/UB SET) - [TC/UB DISPLAY].

### Descriptions of menu items

TC:

Displays the time code.

U-BIT:

Displays the user bit.

#### Hint

- You can assign this function to the ASSIGN button.

---

### Related Topic

- [Assigning the functions to the ASSIGN buttons](#)

Digital 4K Video Camera Recorder  
FDR-AX700

## TC PRESET

---

You can set the time code that is recorded as the time data associated with the movie (Movie mode only).

1 MENU button -  (TC/UB SET) - [TC PRESET].

### Descriptions of menu items

#### PRESET:

Input the time code with ▲ / ▼ / ◀ / ▶ / SET button and select [ OK].

The setting range differs depending on the setting of  (OTHERS) - [60i/50i SEL].

When selecting [ 60i]:

Sets the time code within 00:00:00:00 - 23:59:59:29.

When setting 24p, you can set the last 2 time code digits of the frames in multiples of 4, between 0 and 23.

To return to the previous screen without reflecting the setting, select [ CANCEL].

When selecting [ 50i]:

Sets the time code within 00:00:00:00 - 23:59:59:24.

#### RESET:

Reset the time code (00:00:00:00).

---

### Related Topic

- [60i/50i SEL](#)

Digital 4K Video Camera Recorder  
FDR-AX700

## UB PRESET

---

You can set the user bit that is recorded as the time data associated with the movie (Movie mode only).

1 MENU button -  (TC/UB SET) - [UB PRESET].

### Descriptions of menu items

#### PRESET:

Input the user bit with ▲ / ▼ / ◀ / ▶ / SET button, then select [ OK ].

Sets the user bit within 00 00 00 00 - FF FF FF FF .

To return to the previous screen without reflecting the setting, select [ CANCEL ].

#### RESET:

Reset the user bit (00 00 00 00).

Digital 4K Video Camera Recorder  
FDR-AX700

## TC FORMAT

You can select the time code recording method when  (OTHERS) - [60i/50i SEL] is set to [ 60i] (Movie mode only).

When selecting [ 50i], this setting is fixed to [ NDF].

- 1 MENU button -  (TC/UB SET) - [TC FORMAT].

### Descriptions of menu items

DF:

Records the time code in drop frame.

NDF:

Records the time code in non-drop frame.

### About drop frame

Time code is based on 30 frames per second; however , gaps in the actual time occur during extended periods of recording as the actual frame frequency of NTSC image signal is 29.97 frames per second. Drop frame corrects this gap to make time code and actual time equal.

In drop frame, the first 2 frame numbers are removed every minute except in every tenth minute. Time code without this correction is called non-drop frame.

#### Note

- This setting is fixed to [NDF ] when [ REC FORMAT] is set to the setting value whose frame rate is 24p even if [ 60i] is selected in [ 60i/50i SEL].

### Related Topic

- [REC SET](#)
- [60i/50i SEL](#)

## TC RUN

---

You can select how the time code advances (Movie mode only).

- 1 MENU button - **00:00** (TC/UB SET) - [TC RUN].

### Descriptions of menu items

#### REC RUN:

Advances the time code only during recording.

Select this setting to record the time code sequentially from the last time code of the previous recording.

#### FREE RUN:

Advances the time code regardless of operation of your camcorder .

#### Note

- Even if the time code advances in the [ REC RUN] mode, the time code may not be recorded sequentially i n the following cases.
  - When the recording format is changed.
  - When the memory card is removed.

---

### Related Topic

- [REC SET](#)

Digital 4K Video Camera Recorder  
FDR-AX700

## TC MAKE

---

You can select method for recording the time code on the memory card (Movie mode only).

- 1 MENU button - **00:00** (TC/UB SET) - [TC MAKE].

### Descriptions of menu items

#### PRESET:

Records the newly set time code on the memory card.

#### REGENERATE:

Reads the last time code of the previous recording from the memory card and records the new time code consecutively from the last time code during the backspace editing.

The time code runs in [ REC RUN] mode regardless of the setting of [ TC RUN].

---

### Related Topic

- [TC RUN](#)



Digital 4K Video Camera Recorder  
FDR-AX700

## UB TIME REC

---

You can set whether to record the actual time as the user bit code (Movie mode only).

- 1 MENU button - **00:00** (TC/UB SET) - [UB TIME REC].

### Descriptions of menu items

OFF:

Does not record the actual time as the user bit code.

ON:

Records the actual time as the user bit code.

#### Note

- The last 2 digits are fixed to 00 when it is set to [ON ].

## CTRL W/SMARTPHONE

---

You can control the camcorder remotely with your smartphone.

- 1 MENU button -  (NETWORK SET) - [CTRL W/SMARTPHONE].
  - Connect the smartphone to the camcorder using the information that appears on the LCD monitor when the camcorder is ready to be connected.  
The connection method differs depending on the type of smartphone.

### Hint

- You can assign this function to the ASSIGN button.

---

### Related Topic

- [Connecting to an NFC-enabled smartphone or tablet](#)
- [Connecting to a smartphone or tablet using the QR Code](#)
- [Connecting to your Android smartphone or tablet \(by entering an SSID and password\)](#)
- [Connecting to your iPhone or iPad \(by entering an SSID and password\)](#)
- [Assigning the functions to the ASSIGN buttons](#)

Digital 4K Video Camera Recorder  
FDR-AX700

## Wi-Fi SET

---

You can perform or change the Wi-Fi setting.

- 1 MENU button -  (NETWORK SET) - [Wi-Fi SET].

### Descriptions of menu items

#### EDIT DEVICE NAME:

Changes the camcorder's device name.

#### SSID/PW RESET:

Resets the SSID and password for the smartphone operation.

#### Note

- If [SSID/PW RESET] is performed, it will be necessary to set up the smartphone again, in order to connect it to the camcorder.

---

### Related Topic

- [Connecting to an NFC-enabled smartphone or tablet](#)
- [Connecting to a smartphone or tablet using the QR Code](#)
- [Connecting to your Android smartphone or tablet \(by entering an SSID and password\)](#)
- [Connecting to your iPhone or iPad \(by entering an SSID and password\)](#)

Digital 4K Video Camera Recorder  
FDR-AX700

## AIRPLANE MODE

---

You can disable the Wi-Fi-related settings temporarily when boarding a plane, etc.

- 1 MENU button -  (NETWORK SET) - [AIRPLANE MODE].

### Descriptions of menu items

OFF:

Sets Airplane mode to off.

ON:

Sets Airplane mode to on.

---

### Related Topic

- [Connecting to an NFC-enabled smartphone or tablet](#)
- [Connecting to a smartphone or tablet using the QR Code](#)
- [Connecting to your Android smartphone or tablet \(by entering an SSID and password\)](#)
- [Connecting to your iPhone or iPad \(by entering an SSID and password\)](#)

Digital 4K Video Camera Recorder  
FDR-AX700

## NETWORK RESET

---

You can reset the following network related settings.

- SSID and password for the smartphone operation
- Device name

1 MENU button -  (NETWORK SET) - [NETWORK RESET] - [OK].

- The network settings are reset.
- Select [CANCEL] to cancel resetting.

Digital 4K Video Camera Recorder  
FDR-AX700

## STATUS CHECK

---

You can check the current settings of the camcorder .

- 1 MENU button -  (OTHERS) - [STATUS CHECK].
  - Switch the setting items with the ▲ / ▼ button.

### Hint

- You can assign this function to the ASSIGN button.

---

### Related Topic

- [Checking the settings in the camcorder \( STATUS CHECK\)](#)
- [Assigning the functions to the ASSIGN buttons](#)

Digital 4K Video Camera Recorder  
FDR-AX700

## CAMERA PROFILE

You can save up to 99 camera settings as the camera profile in a memory card for easy recall at any time. In addition, if you should require multiple camcorders with the same settings, you can load the desired settings to all cameras via the memory card.

- 1 MENU button -  (OTHERS) - [CAMERA PROFILE] - select the memory card ([MEMORY CARD A] or [MEMORY CARD B]).

### Descriptions of menu items

#### LOAD:





Loads the camera profile and executes the settings.

Select the camera profile to be loaded with the  /  /  /  / SET button and select [ YES] on the confirmation screen.

The camcorder restarts and the loaded camera profile becomes effective.

#### SAVE:

Saves the camera profile.

Select [ NEW FILE] or an existing profile name with the  /  /  /  / SET button and select [ YES] on the confirmation screen.

#### DELETE:

Deletes the camera profile.

Select the camera profile to be deleted with the  /  /  /  / SET button and select [ YES] on the confirmation screen.

#### Note

- The camera profile may not be shown properly if the file name is changed on the computer, or the power turned off during generation.
- Formatting the memory card also deletes saved camera profiles.
- A camera profile saved on a camcorder with different model name, or edited on a computer cannot be loaded.

#### Hint

- Items that can be saved include setting values for menus, picture profiles, buttons, etc. You can save these setting values all together in the camera profile.
- When you select [NEW FILE] for [SAVE], the camera profile is named [01] (when saving for the first time).
- If you select an existing camera profile when saving the camera profile, the current setting values are overwritten.
- You cannot use a computer to edit saved settings.

Digital 4K Video Camera Recorder  
FDR-AX700

## S&Q BUTTON SETTING

---

You can assign the slow & quick function to the S&Q button (Movie mode only).

- 1 MENU button-  (OTHERS) - [S&Q BUTTON SETTING].

### Descriptions of menu items

#### S&Q/SUPER SLOW:

Switches the effective function in order of Slow & Quick Motion - Super Slow Motion - off each time you press the S&Q button.

#### S&Q MOTION:

Assigns Slow & Quick Motion.

#### SUPER SLOW MOTION:

Assigns Super Slow Motion.

---

### Related Topic

- [Recording with Slow & Quick Motion](#)
- [Recording with Super Slow Motion](#)



Digital 4K Video Camera Recorder  
FDR-AX700

## ASSIGN BUTTON

You can assign the function used frequently to the ASSIGN button for easy operation.

### 1 MENU button- (OTHERS) - [ASSIGN BUTTON].

- Select the ASSIGN button (ASSIGN1 - ASSIGN6), then select the function that you want to assign with ▲ / ▼ / ◀ / ▶ SET button.

### Functions you can assign to the ASSIGN buttons

- — (no function)
- LOW LUX
- FOCUS MAGNIFIER
- LAST SCENE REVIEW
- WHITE BALANCE
- WB PRESET
- WB SET
- AE SHIFT
- D. EXTENDER
- STEADYSHOT
- FOCUS AREA
- FOCUS POSITION
- AF DRIVE SPEED
- AF TRACKING DEPTH
- AF SUBJ. SWITCH. SENS.
- FACE DETECTION
- S&Q MOTION
- AUTO MODE SET
- SCENE SELECTION SET
- NIGHTSHOT
- IRIS PUSH AUTO
- SPOT METER/FOCUS
- SPOT METER
- SPOT FOCUS
- COLOR BAR
- DIRECT
- MENU
- PICTURE PROFILE
- VOLUME
- HISTOGRAM
- ZEBRA
- PEAKING
- PHASE AF FRAMES
- MARKER
- CAMERA DATA DISPLAY
- AUDIO LEVEL DISPLAY
- DATA CODE
- GAMMA DISP ASSIST
- TC/UB DISPLAY
- SMARTPHONE CONNECT
- STATUS CHECK
- REC LAMP

- THUMBNAIL
  -  /  SHOOTING MODE
- 
- 

#### Related Topic

- [Assigning the functions to the ASSIGN buttons](#)

4-725-312-11(2) Copyright 2017 Sony Corporation

Digital 4K Video Camera Recorder  
FDR-AX700

## CLOCK SET

---

You can set the date and time.

- 1 MENU button-  (OTHERS) - [CLOCK SET] – select the desired item .

### Descriptions of menu items

#### AREA SET :

Sets the area where the camcorder is used.

You can adjust a time difference without stopping the clock. When you use your camcorder abroad, you can adjust the clock to the local time.



#### DST SET (SUMMERTIME):

Performs the daylight saving time (summer time) setting.

- OFF: Does not set the daylight saving time (summer time).
- ON: Sets the daylight saving time (summer time).  
Set to [ON] to move the time forward 1 hour .

#### DATE:

Sets the date and time.

Input the date and time with the  /  /  /  /SET button.

---

### Related Topic

- [Initial setting](#)
- [AREA SET](#)
- [DST SET \(SUMMERTIME\)](#)

Digital 4K Video Camera Recorder  
FDR-AX700

## AREA SET

---

You can adjust a time difference without stopping the clock by setting the area where the camcorder is used. When you use your camcorder abroad, you can adjust the clock to the local time.

- 1 MENU button-  (OTHERS) - [AREA SET] – select the desired area.

---

### Related Topic

- [Initial setting](#)

Digital 4K Video Camera Recorder  
FDR-AX700

## DST SET (SUMMERTIME)

---

You can set the daylight saving (summer time).

Set to [ ON] to move the time forward 1 hour .

- 1 MENU button -  (OTHERS) - [DST SET] or [SUMMERTIME] .

### Descriptions of menu items

OFF:

Does not set the daylight saving time (summer time).

ON:

Sets the daylight saving time (summer time).

---

### Related Topic

- [Initial setting](#)

Digital 4K Video Camera Recorder  
FDR-AX700

## LANGUAGE

---

You can select the language for the menu or message to be used on the LCD monitor .

- 1 MENU button -  (OTHERS) - [LANGUAGE].
  - Select the language with the ▲ / ▼ / ◀ / ▶ /SET button.

Digital 4K Video Camera Recorder  
FDR-AX700

## DATE REC

---

You can set whether to superimpose the date and time of shooting on images (only when [ FILE FORMAT] in [REC SET] is set to [ AVCHD]).

- 1 MENU button -  (OTHERS) - [DATE REC].

### Descriptions of menu items

OFF:

Does not superimpose the date and time on images.

ON:

Superimposes the date and time on images.

#### Hint

- The phase detection AF frames are not displayed when [ DATE REC] is set to [ ON].
- When zebra or peaking is activated, the date and time character s are affected by the signal, but properly recorded on images.

---

### Related Topic

- [REC SET](#)
- [ZEBRA](#)
- [PEAKING](#)
- [PHASE AF FRAMES](#)

Digital 4K Video Camera Recorder  
FDR-AX700

## BEEP

---

You can set whether to activate a melody when you start/stop recording, or during operation.

- 1 MENU button -  (OTHERS) - [BEEP].

### Descriptions of menu items

OFF:

Does not activate the melody .

ON:

Activates a melody when you start/stop recording, or when you are warned with warning indicators, etc.



Digital 4K Video Camera Recorder  
FDR-AX700

## REC LAMP

---

You can set whether to turn the recording lamp on during recording.

- 1 MENU button -  (OTHERS) - [REC LAMP].

### Descriptions of menu items

ON:

Turns the recording lamp on during recording.

OFF:

Does not turn the recording lamp on during recording.

#### Hint

- You can assign this function to the ASSIGN button.

---

### Related Topic

- [Assigning the functions to the ASSIGN buttons](#)

Digital 4K Video Camera Recorder  
FDR-AX700

## REMOTE CONTROL

---

You can set whether to enable the supplied wireless remote commander .

- 1 MENU button -  (OTHERS) - [REMOTE CONTROL].

### Descriptions of menu items

ON:

Enables the supplied wireless remote commander .

OFF:

Disables the supplied wireless remote commander .

You can prevent misoperation by the remote control of another device.

---

### Related Topic

- [Parts and controls \(wireless remote commander\)](#)

Digital 4K Video Camera Recorder  
FDR-AX700

## 60i/50i SEL

You can select the setting depending on the TV system of the countries and regions where the camcorder is used.

The camcorder automatically restarts if you change the setting.

- 1 MENU button -  (OTHERS) - [60i/50i SEL].

### Descriptions of menu items

YES:

Changes the setting to 60i (50i).

NO:

Cancels changing the setting.

#### Note

- Select [60i] when the TV system is NTSC and [50i] when the TV system is PAL. TV system currently set is displayed on the setting message.
- A memory card formatted or recorded at 60i (50i) cannot record or play back at 50i (60i), and vice versa. Use another memory card or perform [MEDIA FORMAT] if the [A movie with a different video signal format from the device has been recorded. Movie recording disabled.] message appears after you change the [60i/50i SEL] setting.
- Protected movies are also deleted when [MEDIA FORMAT] is performed.

### Related Topic

- [MEDIA FORMAT](#)

Digital 4K Video Camera Recorder  
FDR-AX700

## MEDIA FORMAT

---

Formatting deletes data from the memory card to recover recordable free space.

If a memory card is used repeatedly, garbage data accumulate which may prevent the image data from being written at the fixed speed. In this case, recording may stop suddenly. You can reduce the writing error during recording by performing [ Empty ] that can erase all the data on the memory card.

- 1 MENU button -  (OTHERS) - [MEDIA FORMAT] - select the memory card that you want to format or perform [ Empty ].

### Descriptions of menu items

OK:

Formats the selected memory card.

Empty :

Erase all the data on the memory card.

[Empty ] is performed by selecting  after selecting [ Empty ].

### Note

- Connect the camcorder to the wall outlet (wall socket) using the supplied AC adaptor to prevent your camcorder from running out of power during the operation.
- You cannot perform [ Empty ] unless you connect the AC Adaptor to the wall outlet (wall socket).
- Disconnect all cables except the AC Adaptor.
- To avoid the loss of important images, you should save them before the operation.
- Protected movies and photos are also deleted.
- While [ Executing... ] is displayed, do not turn off the camcorder, do not operate any buttons on the camcorder, disconnect the AC Adaptor, or remove the memory card from the camcorder. (The access lamp is lit or flashing while formatting memory card.)

---

### Related Topic





- [Using the camcorder supplying power from a wall outlet \(wall socket\)](#)
- [About the memory card](#)
- [Notes on disposal/transfer of the memory card](#)

Digital 4K Video Camera Recorder  
FDR-AX700

## REPAIR IMAGE DB FILE

---

This function checks the database information and the consistency of movies and photos on the memory card, and repairs if any inconsistencies found.

- 1 MENU button -  (OTHERS) - [REPAIR IMAGE DB FILE ] - select the memory card that you want to check the database file.
- 2 Touch  .
  - The database file check starts.  
Touch  and quit the database file check if no inconsistency is found.
- 3 Touch  -  .

### Note

- Connect your camcorder to the wall outlet (wall socket) using the supplied AC Adaptor to prevent your camcorder from running out of power during the operation.
- If you cancel the operation while [Repairing the image database file.] is displayed, be sure to complete the operation as described above before you use the memory card next time.

---

### Related Topic

- [Using the camcorder supplying power from a wall outlet \(wall socket\)](#)

Digital 4K Video Camera Recorder  
FDR-AX700

## USB CONNECT

---

Select this item when the device is not recognized even if it is connected to the camcorder with the USB cable.

- 1 MENU button -  (OTHERS) - [USB CONNECT].
- 

### Related Topic

- [Import and utilize images on your computer \( \[PlayMemories Home\]\(#\)\)](#)
- [Installing the \[PlayMemories Home\]\(#\) software in your computer](#)

Digital 4K Video Camera Recorder  
FDR-AX700

## USB LUN SET

---

You can improve compatibility with external devices by limiting the functions of the USB connection.

- 1 MENU button -  (OTHERS) - [USB LUN SET].

### Descriptions of menu items

#### MULTI:

Select this in normal conditions.

#### SINGLE:

Select this if you cannot make USB connection.

---

---

### Related Topic

- [Import and utilize images on your computer \( \[PlayMemories Home\]\(#\)\)](#)
- [Installing the \[PlayMemories Home\]\(#\) software in your computer](#)

Digital 4K Video Camera Recorder  
FDR-AX700

## OPERATION TIME

---

You can display the total hours of operation in 10-hour increments.

- 1 MENU button -  (OTHERS) - [OPERATION TIME].



Digital 4K Video Camera Recorder  
FDR-AX700

## VERSION DISPLAY

---

You can display the current version of the camcorder .  
Be sure to check for firmware updates.

- 1 MENU button -  (OTHERS) - [VERSION DISPLAY].

### Note

- When performing an update, use the AC Adaptor .

---

### Related Topic

- [Using the camcorder supplying power from a wall outlet](#) (wall socket)

## CALIBRATION

---

You can adjust to match the touch position and touched position on the LCD monitor if the buttons on the touch panel display does not work correctly .

- 1 MENU button -  (OTHERS) - [CALIBRATION].
- 2 Touch "x" displayed on the LCD monitor three times with a fine-tipped object such as the corner of memory card.



### Note

- When performing the calibration, use the AC Adaptor .

---

### Related Topic

- [Using the camcorder supplying power from a wall outlet](#) (wall socket)

Digital 4K Video Camera Recorder  
FDR-AX700

## INITIALIZE

---

You can reset all settings to their default values.

- 1 MENU button -  (OTHERS) - [INITIALIZE].
- 2 Select [OK].
  - All the settings are reset and the camcorder restarts.  
To cancel resetting, select [ CANCEL].

### Note

- The picture profile settings are not reset.

## PROTECT

---

You can protect movies and photos to avoid deleting them by mistake.



1 On the thumbnail or playback screen, select MENU button -  (EDIT) - [PROTECT].

2 Touch the movies or photos to be protected.

-  is displayed on the selected images.



- You can preview the image by pressing and holding the image down. To return to the previous screen, touch .
- You can select up to 100 images at one time.

3 Touch , then follow the on-screen instructions to touch .

To cancel protection

Touch the movies or photos marked with  in step 2 to hide the mark.

---

Related Topic

- [Protecting movies and photos \( PROTECT\)](#)

## DELETE



You can delete unnecessary movies and photos from the memory card.



1 On the thumbnail or playback screen, select MENU button -  (EDIT) - [DELETE].

2 Touch the movies or photos to be deleted.

-  is displayed on the selected images.



- You can preview the image by pressing and holding the image down. To return to the previous screen, touch .
- You can select up to 100 images at one time.
-  appears at the upper right corner on the thumbnail of protected images.
- No check box appears on the thumbnail of protected images.

3 Touch , then follow the on-screen instructions to touch .

### Note

- You cannot restore images once they are deleted.
- Do not remove the battery pack, the AC Adaptor, or the memory card that contains the movies or photos from the camcorder during the operation. It may damage the memory card.
- You cannot delete protected movies and photos. Cancel the protection of the movies and photos before deleting them.
- Save important movies and photos to the computer, etc. in advance.

### Hint

- To delete all data recorded on the memory card and recover all the recordable space of the memory card, format the memory card.

### Related Topic

- [Protecting movies and photos \( PROTECT\)](#)
- [Deleting selected movies/photos](#)
- [Saving movies](#)
- [MEDIA FORMAT](#)





## DIVIDE

You can divide a movie at a designated point (A VCHD movies only).

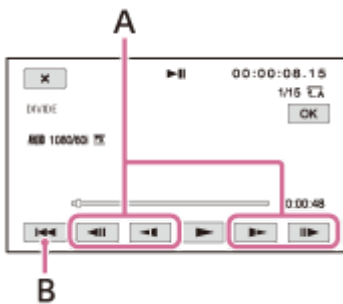

1 During playing movies, select MENU button -  (EDIT) - [DIVIDE].

2 Touch  at the point where you want to divide.





A: After selecting the point with , make fine adjustment with these buttons.

B: Returns to the beginning of the selected movie.

3 Touch  - .

### Note

- You cannot restore movies once they are divided.
- Do not remove the battery pack, AC Adaptor, or memory card that contains the movies from the camcorder during the operation. It may damage the memory card.
- A slight difference may occur from the point where you touch  and the actual dividing point, as the camcorder selects the dividing point based in about half-second increment s.
- Movies recorded in XA VC S cannot be divided.

### Related Topic

- [Playing back movies](#)
- [Dividing a movie](#)

Digital 4K Video Camera Recorder  
FDR-AX700

## Charging time

---

Approximate time (min.) required when you fully charge a fully discharged battery pack.

NP-FV70A (supplied):

170 min.

NP-FV100A (sold separately):

275 min.

### Hint

- The charging times shown above are measured when charging the camcorder at a temperature of 25°C (77°F). It is recommended that you charge the battery in a temperature range of 10°C to 30°C (50°F to 86°F).

---

### Related Topic

- [Charging the battery pack using the AC Adaptor](#)



Digital 4K Video Camera Recorder  
FDR-AX700

## Expected recording time with each battery pack

---

Approximate recording time with each battery pack is shown as follows.

NP-FV70A (supplied):

190 min.

205 min.

NP-FV100A (sold separately):

345 min.

365 min.

Upper time:

When the LCD monitor is opened.

Lower time:

When using the viewfinder with the LCD monitor closed.

### Hint

- Each recording time is the default setting measured with the following settings.
  - [FILE FORMAT]: [XAVC S 4K]
  - [REC FORMAT]: [2160/30p 60Mbps] (60i) or [2160/25p 60Mbps] (50i)
  - [PROXY REC MODE]: [OFF]
- Times measured when using the camcorder at 25°C (77°F). 10°C to 30°C (50°F to 86°F) is recommended.
- The recording and playback time will be shorter, depending on the conditions under which you use the camcorder, such as when use the camcorder in low temperatures.

Digital 4K Video Camera Recorder  
FDR-AX700

## Expected playback time with each battery pack

---

Approximate playback time with each battery pack is shown as follows.

NP-FV70A (supplied):

275 min.

300 min.

NP-FV100A (sold separately):

485 min.

525 min.

Upper time:

When the LCD monitor is opened.

Lower time:

When using the viewfinder with the LCD monitor closed.

### Hint

- Above time is measured when playing back movies continuously with the following default settings.
  - [FILE FORMAT] is [XAVC S 4K] and [REC FORMAT] is [2160/30p 60Mbps].
  - [PROXY REC MODE] is [OFF].

Digital 4K Video Camera Recorder  
FDR-AX700

## Notes on recording movies

---

Read the following precautions regarding movie recording.

### Note

- The recordable time may vary depending on the recording and subject conditions and [ REC SET].
- You can record movies of a maximum of 600 scenes in XAVC S format or 3,999 scenes in AVCHD format. And you can record a maximum of 40,000 photos.
- The maximum continuous recording time of a movie is approximately 13 hours.
- The camcorder uses the VBR (Variable Bit Rate) format to automatically adjust image quality to suit the recording scene. This technology causes fluctuations in the recording time of the memory card. Movies containing quickly moving and complex images are recorded at a higher bit-rate, and this reduces the overall recording time.

## Expected recording time of movie

The following are expected maximum recordable time of total movie files which can be recorded on the memory card formatted by the camcorder .

The recordable time may vary depending on the recording condition and the memory card.

### XAVC S 4K

When selecting [60i ] for [60i/50i SEL]

REC FORMAT	PROXY REC MODE	16 GB	32 GB	64 GB	128 GB	256 GB
2160/30p 100Mbps	ON (1280x720)	15 min.	35 min.	70 min.	145 min.	290 min.
	ON (640x360)	15 min.	35 min.	75 min.	150 min.	305 min.
	OFF	15 min.	35 min.	75 min.	155 min.	315 min.
2160/30p 60Mbps	ON (1280x720)	25 min.	50 min.	110 min.	220 min.	450 min.
	ON (640x360)	25 min.	55 min.	120 min.	240 min.	490 min.
	OFF	30 min.	60 min.	125 min.	255 min.	515 min.
2160/24p 100Mbps	ON (1280x720)	15 min.	35 min.	70 min.	145 min.	290 min.
	ON (640x360)	15 min.	35 min.	75 min.	150 min.	305 min.
	OFF	15 min.	35 min.	75 min.	155 min.	315 min.
2160/24p 60Mbps	ON (1280x720)	25 min.	50 min.	110 min.	220 min.	450 min.
	ON (640x360)	25 min.	55 min.	120 min.	240 min.	490 min.
	OFF	30 min.	60 min.	125 min.	255 min.	515 min.

When selecting [50i] for [60i/50i SEL]

REC FORMAT	PROXY REC MODE	16 GB	32 GB	64 GB	128 GB	256 GB
2160/25p 100Mbps	ON (1280x720)	15 min.	35 min.	70 min.	145 min.	290 min.
	ON (640x360)	15 min.	35 min.	75 min.	150 min.	305 min.
	OFF	15 min.	35 min.	75 min.	155 min.	315 min.
2160/25p 60Mbps	ON (1280x720)	25 min.	50 min.	110 min.	220 min.	450 min.
	ON (640x360)	25 min.	55 min.	120 min.	240 min.	490 min.
	OFF	30 min.	60 min.	125 min.	255 min.	515 min.

### XAVC S HD

When selecting [60i ] for [60i/50i SEL]

REC FORMAT	PROXY REC MODE	16 GB	32 GB	64 GB	128 GB	256 GB
1080/120p 100Mbps	OFF	15 min.	35 min.	75 min.	155 min.	315 min.
1080/120p 60Mbps	OFF	30 min.	60 min.	125 min.	255 min.	515 min.
1080/60p 50Mbps	ON (1280x720)	30 min.	60 min.	130 min.	260 min.	530 min.
	ON (640x360)	30 min.	70 min.	145 min.	290 min.	585 min.
	OFF	35 min.	75 min.	150 min.	310 min.	625 min.
1080/60p 25Mbps	ON (1280x720)	50 min.	110 min.	220 min.	445 min.	900 min.
	ON (640x360)	60 min.	130 min.	265 min.	535 min.	1,080 min.
	OFF	70 min.	145 min.	300 min.	600 min.	1,210 min.
1080/30p 50Mbps	ON (1280x720)	30 min.	60 min.	130 min.	260 min.	530 min.
	ON (640x360)	30 min.	70 min.	145 min.	290 min.	585 min.
	OFF	35 min.	75 min.	150 min.	310 min.	625 min.
1080/30p 16Mbps	ON (1280x720)	70 min.	150 min.	300 min.	610 min.	1,230 min.
	ON (640x360)	90 min.	190 min.	390 min.	790 min.	1,585 min.
	OFF	110 min.	230 min.	465 min.	940 min.	1,885 min.
1080/24p 50Mbps	ON (1280x720)	30 min.	60 min.	130 min.	260 min.	530 min.
	ON (640x360)	30 min.	70 min.	145 min.	290 min.	585 min.
	OFF	35 min.	75 min.	150 min.	310 min.	625 min.

When selecting [50i ] for [60i/50i SEL]

REC FORMAT	PROXY REC MODE	16 GB	32 GB	64 GB	128 GB	256 GB
1080/100p 100Mbps	OFF	15 min.	35 min.	75 min.	155 min.	315 min.
1080/100p 60Mbps	OFF	30 min.	60 min.	125 min.	255 min.	515 min.
1080/50p 50Mbps	ON (1280x720)	30 min.	60 min.	130 min.	260 min.	530 min.
	ON (640x360)	30 min.	70 min.	145 min.	290 min.	585 min.
	OFF	35 min.	75 min.	150 min.	310 min.	625 min.
1080/50p 25Mbps	ON (1280x720)	50 min.	110 min.	220 min.	445 min.	900 min.
	ON (640x360)	60 min.	130 min.	265 min.	535 min.	1,080 min.
	OFF	70 min.	145 min.	300 min.	600 min.	1,210 min.
1080/25p 50Mbps	ON (1280x720)	30 min.	60 min.	130 min.	260 min.	530 min.
	ON (640x360)	30 min.	70 min.	145 min.	290 min.	585 min.
	OFF	35 min.	75 min.	150 min.	310 min.	625 min.
1080/25p 16Mbps	ON (1280x720)	70 min.	150 min.	300 min.	610 min.	1,230 min.
	ON (640x360)	90 min.	190 min.	390 min.	790 min.	1,585 min.
	OFF	110 min.	230 min.	465 min.	940 min.	1,885 min.

## AVCHD

When selecting [60i ] for [60i/50i SEL]

REC FORMAT	16 GB	32 GB	64 GB	128 GB	256 GB
1080/60i FX	85 min.	175 min.	360 min.	725 min.	1,455 min.
1080/60i FH	120 min.	245 min.	495 min.	995 min.	1,995 min.
1080/60i LP	375 min.	765 min.	1,540 min.	3,090 min.	6,200 min.

When selecting [50i ] for [60i/50i SEL]

REC FORMAT	16 GB	32 GB	64 GB	128 GB	256 GB
1080/50i FX	85 min.	175 min.	360 min.	725 min.	1,455 min.
1080/50i FH	120 min.	245 min.	495 min.	995 min.	1,995 min.
1080/50i LP	375 min.	765 min.	1,540 min.	3,090 min.	6,200 min.

### Note

- The times shown are recordable times using a Sony memory card.
- The maximum continuous recording time for a movie is approximately 13 hours.
- The camcorder uses the VBR (Variable Bit Rate) format to automatically adjust image quality to suit the recording scene. This technology causes fluctuations in the recording time of the media. Movies containing quickly moving and complex images are recorded at a higher bit-rate, and this reduces the overall recording time.

### Related Topic

- [Notes on recording movies](#)
- [60i/50i SEL](#)

Digital 4K Video Camera Recorder  
FDR-AX700

## Expected number of recordable photos

The following are expected recordable number of photos which can be recorded on the memory card formatted by the camcorder .

### Number of photos of 14.2 M

(Units: Images)

Capacity	16 GB	32 GB	64 GB	128 GB	256 GB
Recordable number of photos	1,750	3,550	7,100	14,000	28,500

### Number of photos of 12.0 M

(Units: Images)

Capacity	16 GB	32 GB	64 GB	128 GB	256 GB
Recordable number of photos	2,100	4,250	8,400	16,500	33,500

#### Note

- The numbers shown are when using a Sony memory card.
- The above number is for the maximum image size of the camcorder . The actual number of recordable photos is displayed on the LCD monitor during recording.
- When the number of recordable photos is 9,999 or more, it is shown as ">9999".
- The number of recordable photos of memory card may vary depending on the recording conditions.

#### Related Topic

- [Notes on recording movies](#)

Digital 4K Video Camera Recorder  
FDR-AX700

## Bit-rate and recording pixels

---

The following list shows the bit-rate, pixels and aspect ratio of each recording mode for movies (movie + audio, etc.).

### XAVC S 4K:

When selecting 100Mbps format for [ REC FORMAT]:

Max. 100 Mbps 3,840 × 2,160 pixels/30p, 24p (60i), 25p (50i), 16:9

When selecting 60Mbps format for [ REC FORMAT]:

Max. 60 Mbps 3,840 × 2,160 pixels/30p, 24p (60i), 25p (50i), 16:9

### XAVC S HD:

Approx. 100 Mbps 1,920 × 1,080 pixels/120p (60i), 100p (50i), 16:9

Approx. 60 Mbps 1,920 × 1,080 pixels/120p (60i), 100p (50i), 16:9

Approx. 50 Mbps 1,920 × 1,080 pixels/60p, 30p, 24p (60i), 50p, 25p (50i), 16:9

Approx. 25 Mbps 1,920 × 1,080 pixels/60p (60i), 50p (50i), 16:9

Approx. 16 Mbps 1,920 × 1,080 pixels/30p (60i), 25p (50i), 16:9

### AVCHD:

#### FX :

Max. 24 Mbps 1,920 × 1,080 pixels/60i (60i), 50i (50i), A VCHD 24 M (FX), 16:9

FH (bit-rate is average value):

Approx. 17 Mbps 1,920 × 1,080 pixels/60i (60i), 50i (50i), A VCHD 17 M (FH), 16:9

LP (bit-rate is average value) :

Approx. 5 Mbps 1,440 × 1,080 pixels/60i (60i), 50i (50i), A VCHD 5M (LP), 16:9

---

### Related Topic

- [Notes on recording movies](#)



Digital 4K Video Camera Recorder  
FDR-AX700

## Recording pixels and aspect ratio of Proxy recording

---

Explains the recording pixels and the aspect ratio of Proxy recording.

1,280 × 720 dots/16:9

640 × 360 dots/16:9

Digital 4K Video Camera Recorder  
FDR-AX700

## Recording pixels and aspect ratio of photos

---

Explains the recording pixels and the aspect ratio of photos.

5,024 × 2,824 dots/16:9

4,240 × 2,824 dots/3:2

Digital 4K Video Camera Recorder  
FDR-AX700

## About XA VC S format

---

What is XA VC S?

XAVC S is a recording format that allows high-resolution images, such as 4K, to be highly compressed with MPEG-4 AVC/H.264 and recorded in the MP4 file format. High image quality will be obtained while keeping the data size within a certain level.

---

---

Related Topic

- [REC SET](#)

Digital 4K Video Camera Recorder  
FDR-AX700

## About the AVCHD format

---

What is the AVCHD format?

The AVCHD format is a high definition digital video camera format used to record a high definition (HD) signal using efficient data compression coding technology. The MPEG-4 AVC/H.264 format is adopted to compress video data, and the Dolby Digital or Linear PCM system is used to compress audio data. The MPEG-4 AVC/H.264 format is capable of compressing images at higher efficiency than that of the conventional image compressing format.

### Hint

- As the AVCHD format uses a compression coding technology, the picture may be disturbed in scenes where picture, field angles or brightness, etc. change drastically, but this is not a malfunction.

---

Related Topic

- [REC SET](#)

## About the memory card

- A memory card formatted by a computer (Windows OS/Mac OS) is not guaranteed to be compatible with the camcorder.
- Data read/write speed may vary depending on the combination of the memory card and memory card compliant product you use.
- Data may be damaged or lost in the following cases (the data will not be compensated for):
  - If you eject the memory card, or turn off the camcorder while the camcorder is reading or writing image files on the memory card (while the access lamp is lit or flashing)
  - If you use the memory card near magnets or magnetic fields
- It is recommended that you make a back-up of important data on the hard disk of a computer.
- Do not attach a label or the like on memory card or memory card adaptor. Doing so may cause a malfunction.
- Do not touch, or allow metallic objects to come into contact with the terminals.
- Do not bend, drop or apply strong force to the memory card.
- Do not disassemble or modify the memory card.
- Do not allow the memory card to get wet.
- Keep the memory card out of the reach of small children. There is danger that a child might swallow it.
- Do not insert anything other than the compliant size of memory card into the memory card slot. Doing so may cause a malfunction.
- Do not use or keep the memory card in the following locations:
  - Places subject to extremely high temperature, such as a car parked outside in the sun
  - Places under direct sunlight
  - Places with extremely high humidity or subject to corrosive gases

### On types of memory card you can use with the camcorder

- You can use only Memory Stick PRO Duo media, Memory Stick PRO-HG Duo media, or standard sized SD card.

### On the memory card adaptor

- When you use the camcorder with the Memory Stick Micro media or microSD memory card, insert into a dedicated card adaptor and connect it to the camcorder.

### On image data compatibility

- Image data files recorded on memory card by the camcorder conform to the “Design rule for Camera File system” universal standard established by the JEITA (Japan Electronics and Information Technology Industries Association).
- If you cannot use memory cards that have been used with another device, format them with the camcorder. Note that formatting erases all information on the memory card.
- Movies saved on SDXC memory cards cannot be imported to or played back on computers or AV devices not supporting the exFAT(\*) file system by connecting the camcorder to these devices with the USB cable. Confirm in advance that the connecting equipment is supporting the exFAT system. If you connect equipment not supporting the exFAT system and a message that prompts you to perform formatting appears, do not perform the formatting. All the data saved will be lost.

\* The exFAT is a file system that is used for SDXC memory cards.

- You may not be able to play back images with the camcorder:
  - When playing back image data modified on your computer
  - When playing back image data recorded with other devices

## About the Memory Stick media

Memory Stick Duo media (with MagicGate):

Recording/Playback: not supported

Memory Stick PRO Duo (Mark2) media:

Recording/Playback: supported (\*)

Memory Stick PRO-HG Duo media :

Recording/Playback: supported (\*)

\* Except for XAVC S format

- The camcorder does not support 8-bit parallel data transfer but it supports 4-bit parallel data transfer the same as with Memory Stick PRO Duo media.
- The camcorder cannot record or play back data that uses MagicGate technology . MagicGate is a copyright protection technology that records and transfers the contents in an encrypted format.

4-725-312-11(2) Copyright 2017 Sony Corporation

Digital 4K Video Camera Recorder  
FDR-AX700

## About the InfoLITHIUM battery pack

The camcorder operates only with InfoLITHIUM V series battery packs. Other series battery packs are not available. InfoLITHIUM V series battery packs have the  mark.

### What is an InfoLITHIUM battery pack?

- An InfoLITHIUM battery pack is a lithium-ion battery pack that has functions for communicating information related to operating conditions between the camcorder and an AC Adaptor/charger (sold separately).
- The InfoLITHIUM battery pack calculates the power consumption according to the operating conditions of the camcorder, and displays the remaining battery capacity in percent (%).

### To charge the battery pack

- Be sure to charge the battery pack before you start using the camcorder.
- We recommend that you charge the battery pack in an ambient temperature range of 10°C to 30°C (50°F to 86°F) until the POWER/CHG (charge) lamp turns off. If you charge the battery pack outside of this temperature range, you may not be able to charge it efficiently.
- The POWER/CHG (charge) lamp flashes during charging under the following conditions.
  - The battery pack is not attached correctly.
  - The battery pack is damaged.
  - The temperature of the battery pack is low.  
Remove the battery pack from the camcorder and put it in a warm place.
  - The temperature of the battery pack is high.  
Remove the battery pack from the camcorder and put it in a cool place.

### To use the battery pack effectively

- Battery pack performance decreases when the ambient temperature is 10°C (50°F) or below, and the length of time you can use the battery pack becomes shorter. If that happens, one of the following is recommended to enable longer use of the battery pack:
  - Put the battery pack in a pocket to warm it up, and install it on the camcorder immediately before you start shooting.
  - Use a large capacity battery pack: NP-FV100A (sold separately).
- Frequent use of the LCD monitor or a frequent playback, fast forward or reverse operation wears out the battery pack faster.
- Be sure to close the LCD monitor when not recording or playing back on the camcorder. The battery pack is also consumed when the camcorder is in recording standby or playback pause.
- Have spare battery packs ready for 2 or 3 times the expected recording time, and make trial recordings before making the actual recording.
- Do not expose the battery pack to water. The battery pack is not water resistant.

### About the remaining battery power indicator

- When the power goes off even though the remaining battery power indicator indicates that the battery pack has enough power to operate, charge the battery pack fully again. Remaining battery power will be indicated correctly. Note, however, that the battery indication will not be restored if it is used in high temperatures for a long time, or if left in a fully charged state, or when the battery pack is frequently used.
- Depending on the operating conditions or ambient temperature, the  icon that indicates a low battery may flash even if there are still about 10% of power remaining.

## About storage of the battery pack

- If the battery pack is not used for a long time, fully charge the battery pack and use it up on the camcorder once a year to maintain proper function. To store the battery pack, remove it from the camcorder and put it in a dry, cool place.
- To discharge the battery pack on the camcorder completely, leave the camcorder in recording standby until the power goes off.

## About battery life

- Battery capacity decreases over time and through repeated use. If the interval between charges becomes significantly short, the battery pack may need to be replaced with a new one.
- Each battery's life depends on storage, operating and environmental conditions.



## On use and care

### On recording

- Before starting to record, test the recording function to make sure the image and sound are recorded without any problems.
- Compensation for the contents of recordings cannot be provided, even if recording or playback is not possible due to a malfunction of the camcorder, memory card, etc.
- TV color systems differ depending on the country/region. To view your recordings on a TV, you need a TV that supports the signal format for the camcorder.
- Television programs, films, video tapes, and other materials may be copyrighted. Unauthorized recording of such materials may be contrary to the copyright laws.

### LCD monitor

- The LCD monitor is manufactured using extremely high-precision technology, so over 99.99% of the pixels are operational for effective use. However, there may be some tiny black points and/or bright points (white, red, blue, or green in color) that appear constantly on the LCD monitor. These points are normal results of the manufacturing process and do not affect the shooting in any way.

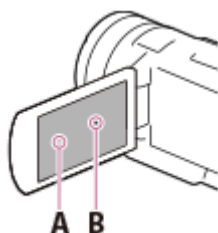

- A: White, red, blue or green points  
B: Black points

### About this Help Guide, illustrations and on-screen displays

- The example images used in this Help Guide for illustration purposes are captured using a digital still camera, and therefore may appear different from images and screen indicators that actually appear on the camcorder. And, the illustrations of the camcorder and its screen indication are exaggerated or simplified for understandability.
- Design and specifications of the camcorder and accessories are subject to change without notice.
- In this Help Guide, DVD discs recorded with high definition image quality (HD) are called A VCHD disc.

### On use and storage place

- The camcorder is not dustproofed, dripproofed or waterproofed.
- Do not hold the camcorder by the following parts, and also do not hold the camcorder by the jack covers.

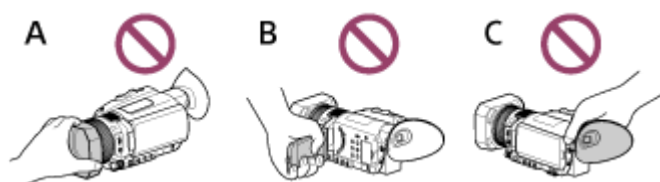

- A: Lens hood  
B: LCD monitor  
C: Viewfinder

- Do not aim the camcorder at the sun. Doing so might cause the camcorder to malfunction. Take images of the sun only in low light conditions, such as at dusk.
- Do not use or store the camcorder and accessories in the following locations:
  - Anywhere extremely hot, cold or humid.  
Never leave them exposed to temperatures above 60°C (140°F), such as under direct sunlight, near heaters or in a car parked in the sun.  
They may malfunction or become deformed.
  - Near strong magnetic fields or mechanical vibration.  
The camcorder may malfunction.
  - Near strong radio waves or radiation.  
The camcorder may not be able to record properly.
  - Near tuner devices such as TVs or radio.  
Noise may occur.
  - On a sandy beach or anywhere dusty.  
If sand or dust gets in the camcorder, it may malfunction. Sometimes this malfunction cannot be repaired.
  - Near windows or outdoors, where the LCD monitor, the viewfinder, or the lens may be exposed to direct sunlight.  
This damages the inside of the LCD monitor or the viewfinder.

### When not using the camcorder for a long time

- To keep the camcorder in optimum state for a long time, turn it on and let it run by recording and playing back images about once a month.
- Use up the battery pack completely before storing it.

### Note on the camcorder/battery pack temperature

- When the temperature of the camcorder or battery pack becomes extremely high or extremely low, you may not be able to record or play back on the camcorder, due to the protection features of the camcorder being activated in such situations. In this case, a message appears on the LCD monitor or the viewfinder.

### LCD monitor

- Do not apply excessive pressure on the LCD monitor, as it may cause uneven color and other damage.
- If the camcorder is used in a cold place, a residual image may appear on the LCD monitor. This is not a malfunction.
- While using the camcorder, the back of the LCD monitor may heat up. This is normal.

### Multi interface shoe

- When using a dedicated microphone or portable speaker, their power turns on or off according to the power of the camcorder.
- For details, refer to the operating instructions supplied with the accessories.
- To attach an accessory, insert and fix the accessory to the Multi interface shoe by holding it down and sliding forward until it stops. To remove the accessory, hold it down and slide it back.
- When you are recording movies with an external flash (sold separately) connected to the Multi interface shoe, turn off the power of the external flash to prevent charging noise from being recorded.
- When an external microphone (sold separately) is connected, it takes priority over the built-in microphone.

### ZEISS lens

- The camcorder is equipped with a ZEISS lens, which was developed jointly by ZEISS, in Germany, and Sony Corporation, and produces superior images. It adopts the MTF(\*) measurement system for video cameras and offers a quality typical of a ZEISS lens.
- Also, the lens for the camcorder is T\*-coated to suppress unwanted reflections and faithfully reproduce colors.

\* MTF= Modulation Transfer Function. The number value indicates the amount of light from a subject coming into the lens.

### On the pre-installed rechargeable battery

- The camcorder has a pre-installed rechargeable battery to retain the date, time, and other settings even when the LCD monitor is closed. The pre-installed rechargeable battery is always charged while the camcorder is connected to a wall outlet (wall socket) via the AC Adaptor or while the battery pack is inserted. The rechargeable battery will be fully discharged in about 2 months if you do not use the camcorder at all. Charge the pre-installed rechargeable battery before you start using the camcorder. However, even if the pre-installed rechargeable battery is not charged, the camcorder operation other than date recording will not be affected.

How to charge the pre-installed rechargeable battery

Connect the camcorder to a wall outlet (wall socket) using the supplied AC Adaptor, or attach the fully-charged battery pack and leave it with the LCD monitor closed for more than 24 hours.

## On connecting to a computer or accessory etc.

---

- Do not try to format the memory card of the camcorder with a computer . If you do so, the camcorder may not operate correctly .
- When connecting the camcorder to another device with communication cables, be sure to insert the connector plug in the correct way . Pushing the plug forcibly into the terminal will damage the terminal and may result in a malfunction of the camcorder .
- When the camcorder is connected to a computer through a USB connection and the camcorder is turned on, do not turn off the computer . The image data that has been recorded may be lost.

Digital 4K Video Camera Recorder  
FDR-AX700

## Notes on optional accessories

---

- We recommend using genuine Sony accessories.
- Genuine Sony accessories may not be available in some countries/regions.

4-725-312-11(2) Copyright 2017 Sony Corporation

Digital 4K Video Camera Recorder  
FDR-AX700

## On moisture condensation

---

If the camcorder is brought directly from a cold place to a warm place, moisture may condense inside the camcorder . This may cause a malfunction to the camcorder .

### If moisture condensation occurs

Leave the camcorder for about 1 hour without turning it on.

### Where moisture condensation frequently occurs

Moisture may condense when you bring the camcorder from a cold place into a warm place (or vice versa) or when you use the camcorder in a humid place as follows:

- You bring the camcorder from a ski slope into a place warmed up by a heating device.
- You bring the camcorder from an air conditioned car or room into a hot place outside.
- You use the camcorder after a squall or a rain.
- You use the camcorder in a hot and humid place.

### How to prevent moisture condensation

When you bring the camcorder from a cold place into a warm place, put the camcorder in a plastic bag and seal it tightly . Remove the bag when the air temperature inside the plastic bag has reached the surrounding temperature (after about 1 hour).

Digital 4K Video Camera Recorder  
FDR-AX700

## Notes on disposal/transfer the ownership of the camcorder

---

For the network related information on the camcorder , perform [ NETWORK RESET] to reset the connection information.

---

---

### Related Topic

- [NETWORK RESET](#)

Digital 4K Video Camera Recorder  
FDR-AX700

## Notes on disposal/transfer of the memory card

---

Even if you perform [ MEDIA FORMAT] or format the memory card by using the computer function, you may not delete data from the memory card completely . When you give the memory card to somebody , it is recommended that you delete data completely using data deletion software on a computer . Also, when you dispose of the memory card, it is recommended that you destroy the actual body of the memory card.

---

### Related Topic

- [MEDIA FORMAT](#)



Digital 4K Video Camera Recorder  
FDR-AX700

## On handling the LCD monitor

---

- If you leave fingerprints, hand cream, etc. on the LCD monitor, the coating of the LCD monitor will come off easily. Wipe those off as soon as possible.
- If you wipe the LCD monitor strongly with a tissue, etc., the coating of the LCD monitor may be scratched.
- If the LCD monitor becomes dirty with fingerprints or dust, it is recommended that you gently remove those from the screen then clean it with a soft cloth, etc.

Digital 4K Video Camera Recorder  
FDR-AX700

## Care of the OLED panel display

---

The OLED panel may experience issues such as screen burn-in or loss of brightness with normal use over time. This is not a malfunction.

Digital 4K Video Camera Recorder  
FDR-AX700

## To clean the casing

---

- Wipe the casing gently with a soft cloth such as a cleaning cloth or eyeglass cleaning cloth.
- If the casing is very dirty , clean the casing of the camcorder with a soft cloth lightly moistened with water , and then wipe the casing with a dry soft cloth.
- Avoid the following so as not to deform the casing or damage the finish and lens surface:
  - Using chemicals such as thinner , benzine, alcohol, chemical cloths, insect repellent, insecticide and sunscreen
  - Handling the camcorder with the above substances on your hands
  - Leaving the camcorder in contact with rubber or vinyl objects for a long period of time

Digital 4K Video Camera Recorder  
FDR-AX700

## About care and storage of the lens

---

- Wipe the surface of the lens clean with a soft cloth in the following instances:
  - When there are fingerprints on the lens surface
  - In hot or humid locations
  - When the lens is exposed to salty air such as at the seaside
- Store in a well-ventilated location subject to little dirt or dust.
- To prevent mold, periodically clean and store the lens as described above.

Digital 4K Video Camera Recorder  
FDR-AX700

## Using the camcorder abroad

---

### Power supply

- You can use the camcorder in any countries/regions using the AC Adaptor supplied with the camcorder within the AC 100 V to 240 V , 50 Hz/60 Hz range. You can also charge the battery pack.

### Viewing images in 4K

- To view 4K images in 4K, you need to connect the camcorder to a 4K compatible TV (or monitor) using an HDMI cable (sold separately). To view the movies recorded with your camcorder on a TV , set [60i/50i SEL] in advance to the appropriate TV system for the country/region in which you intend to watch the movies. See "Countries/regions where you need to set [ 60i/50i SEL ] to [60i]" and "Countries/regions where you need to set [ 60i/50i SEL ] to [ 50i]" for countries and regions where your TV system supports each setting.

### Viewing high definition image quality (HD) movies

- To view high definition (HD) images in HD, you need to connect the camcorder to an HD compatible TV (or monitor) using an HDMI cable (sold separately). To view the movies recorded with your camcorder on a TV , set [ 60i/50i SEL ] in advance to the appropriate TV system for the country/region in which you intend to watch the movies. See "Countries/regions where you need to set [ 60i/50i SEL ] to [60i]" and "Countries/regions where you need to set [ 60i/50i SEL ] to [ 50i]" for countries and regions where your TV system supports each setting.

### Viewing images on a TV connected

- To view images on a TV (or monitor), you need to connect the camcorder to a TV (or monitor) using an HDMI cable (sold separately) or an A/V cable (sold separately). To view the movies recorded with your camcorder on a TV, set [60i/50i SEL] in advance to the appropriate TV system for the country/region in which you intend to watch the movies. See "Countries/regions where you need to set [ 60i/50i SEL ] to [60i]" and "Countries/regions where you need to set [ 60i/50i SEL ] to [ 50i]" for countries and regions where your TV system supports each setting.

### Countries/regions where you need to set [ 60i/50i SEL ] to [60i ]

- Bahama Islands, Bolivia, Canada, Central America, Chile, Colombia, Ecuador , Guyana, Jamaica, Japan, Korea, Mexico, Peru, Surinam, Taiwan, the Philippines, the U.S.A., Venezuela, etc.

### Countries/regions where you need to set [ 60i/50i SEL ] to [50i ]

- Argentina, Australia, Austria, Belgium, Brazil, Bulgaria, China, Croatia, Czech Republic, Denmark, Finland, France, French Guiana, Germany , Greece, Holland, Hong Kong, Hungary , Indonesia, Iran, Iraq, Italy , Kuwait, Malaysia, Monaco, New Zealand, Norway , Paraguay , Poland, Portugal, Romania, Russia, Singapore, Slovak Republic, Spain, Sweden, Switzerland, Thailand, Turkey, Ukraine, United Kingdom, Uruguay , Vietnam, etc.

### Setting to the local time

- You can easily set the clock to the local time by setting a time difference when using the camcorder abroad. Press the MENU button - select  (OTHERS) - [AREA SET].

- Viewing images on a 4K TV
- Viewing images on a high definition TV
- Viewing images on a non-high-definition TV
- 60i/50i SEL
- AREA SET

4-725-312-11(2) Copyright 2017 Sony Corporation

## On trademarks

- Handycam and **HANDYCAM** are registered trademarks of Sony Corporation.
- AVCHD and AVCHD logotype are trademarks of Sony Corporation and Panasonic Corporation.
- XAVC S and **XAVC S** are registered trademarks of Sony Corporation.
- PlayMemories Home, the PlayMemories Home logo, PlayMemories Online, the PlayMemories Online logo, PlayMemories Mobile and the PlayMemories Mobile logo are trademarks of Sony Corporation.
- Memory Stick, , Memory Stick Duo, **MEMORY STICK DUO**, Memory Stick PRO Duo, **MEMORY STICK PRO DUO**, Memory Stick PRO-HG Duo, **MEMORY STICK PRO-HG DUO**, MagicGate, **MAGICGATE**, MagicGate Memory Stick and MagicGate Memory Stick Duo are trademarks or registered trademarks of Sony Corporation.
- InfoLITHIUM is a trademark of Sony Corporation.
- BRAVIA is a trademark of Sony Corporation.
- Blu-ray Disc™ and Blu-ray™ are trademarks of the Blu-ray Disc Association.
- Dolby and the double-D symbol are trademarks of Dolby Laboratories.
- The terms HDMI and HDMI High-Definition Multimedia Interface, and the HDMI logo are trademarks or registered trademarks of HDMI Licensing LLC in the United States and other countries.
- Microsoft, Windows, and DirectX are either registered trademarks or trademarks of Microsoft Corporation in the United States and/or other countries.
- Mac and Mac OS are registered trademarks of Apple Inc. in the United States and other countries.
- iPhone and iPad are trademarks of Apple Inc., registered in the U.S. and other countries.
- Android and Google Play are trademarks of Google Inc.
- Wi-Fi, the Wi-Fi logo and Wi-Fi PROTECTED SET-UP are registered trademarks of the Wi-Fi Alliance.
- The N mark is a trademark or registered trademark of NFC Forum, Inc. in the United States and in other countries.
- QR Code is registered trademark of DENSO WAVE INCORPORATED.
- SDXC logo is a trademark of SD-3C, LLC.
- Facebook and the “f” logo are trademarks or registered trademarks of Facebook, Inc.
- Twitter and the Twitter logo are trademarks or registered trademarks of Twitter, Inc.
- YouTube and the YouTube logo are trademarks or registered trademarks of Google Inc.
- All other product names mentioned herein may be the trademarks or registered trademarks of their respective companies. Furthermore, ™ and ® are not mentioned in each case in this Help Guide.

Digital 4K Video Camera Recorder  
FDR-AX700

## Notes on the License

THIS PRODUCT IS LICENSED UNDER THE AVC PATENT PORTFOLIO LICENSE FOR THE PERSONAL AND NON-COMMERCIAL USE OF A CONSUMER TO

(i) ENCODE VIDEO IN COMPLIANCE WITH THE AVC STANDARD ( "AVC VIDEO") AND/OR

(ii) DECODE AVC VIDEO THAT WAS ENCODED BY A CONSUMER ENGAGED IN A PERSONAL AND NON-COMMERCIAL ACTIVITY AND/OR WAS OBTAINED FROM A VIDEO PROVIDER LICENSED TO PROVIDE AVC VIDEO.

NO LICENSE IS GRANTED OR SHALL BE IMPLIED FOR ANY OTHER USE.

ADDITIONAL INFORMATION MAY BE OBTAINED FROM MPEG LA, L.L.C.

SEE <[HTTP://WWW.MPEGLA.COM](http://www.mpegla.com)>

We provide the software in this product based on license agreements with the owners of the respective copyrights. Based on requests by the owners of copyright of these software applications, we have an obligation to inform you of the following. Please read the following sections.

### On GNU GPL/LGPL applied software

The software that is eligible for the following GNU General Public License (hereinafter referred to as "GPL") or GNU Lesser General Public License (hereinafter referred to as "LGPL") are included in this product.

This informs you that you have a right to have access to, modify , and redistribute source code for these software programs under the conditions of the supplied GPL/LGPL.

Source code is provided on the web. Use the following URL to download it.

<http://oss.sony.net/Products/Linux>

We would prefer you do not contact us about the contents of source code.

Copies of the licenses (in English) are stored in the internal memory of this product. Establish a Mass Storage connection between this product and a computer , and read the files in the "LICENSE" folder in "PMHOME."



Digital 4K Video Camera Recorder  
FDR-AX700

## Zoom magnifications

---

Optical zoom: 12× when [ZOOM TYPE] is set to [ OPTICAL ZOOM ONLY].

Clear image zoom: 24× (18× in 4K) when [ ZOOM TYPE] is set to [ ON[CLEAR IMAGE ZOOM] ].

Digital zoom: 192× when [ ZOOM TYPE] is set to [ ON[DIGITAL ZOOM]].

---

### Related Topic

- [Adjusting the zoom with the zoom lever](#)
- [Adjusting the zoom with the manual lens ring](#)
- [ZOOM SET](#)

Digital 4K Video Camera Recorder  
FDR-AX700

## Using the camcorder after a long time

---

In case you have not used the camcorder for several months, check the following before use.

- When the date and clock settings are initialized, reset it by pressing the MENU button and selecting (OTHERS) - [CLOCK SET]. 
  - Be sure to charge the battery pack of the camcorder before use. For details, see “ [Charging the battery pack using the AC Adaptor](#) ”
  - It may be required to change the movie format to view images recorded in the past. For details, see “ [Playing back movies](#) .”
- 

### Related Topic

- [CLOCK SET](#)
- [Charging the battery pack using the AC Adaptor](#)
- [Playing back movies](#)

Digital 4K Video Camera Recorder  
FDR-AX700

## If you have problems

---

If you run into any problems using the camcorder , follow the steps below .

- 1 Check the items under “T roubles shooting,” and inspect the camcorder .
- 2 Disconnect the power source, attach the power source again after about 1 minute, and turn the camcorder on.
- 3 Perform [INITIALIZE ] to restart the camcorder .
  - If you perform this operation, settings such as the clock setting or area setting are reset.
- 4 Contact your Sony dealer or local authorized Sony service facility .

---

### Related Topic

- [INITIALIZE](#)

Digital 4K Video Camera Recorder  
FDR-AX700

## Self-diagnosis display

If indicators appear on the LCD monitor or in the viewfinder, check the following. If the problem persists even after you have tried to fix a couple of times, contact your Sony dealer or local authorized Sony service facility. When you contact them, give them the complete error code beginning with C or E displayed on the LCD monitor.



You may hear a melody when an important warning indicator appears on the LCD monitor.

C:(or E:) □ □ : □ □ (Self-diagnosis display)

C:04: □ □

You are not using the designated battery pack. Make sure to use the designated battery pack. Connect the DC plug of the AC Adaptor to the DC IN jack of the camcorder firmly.

C:06: □ □

The battery pack temperature is high. Change the battery pack or place it in a cool place.

C:13: □ □

Remove the memory cards. After installing them again, operate your camcorder.

C:32: □ □

Remove the power source. Reconnect it and operate the camcorder again.

E: □ □ : □ □

Follow the steps from 2 on “ [If you have problems](#) .”

 (Battery level warning)

Low battery .

Depending on the operating environment or battery conditions,  may flash even with about 10% of power remaining.

 (Warning indicator pertaining to the temperature of the camcorder /battery pack)

The temperature of the camcorder/battery pack is high. In this case, leave the power off and wait until the temperature of the camcorder/battery pack goes down.

 (Warning indicator pertaining to memory card)

Slow flashing

Free spaces for recording images are running out.

No memory card is inserted.

Fast flashing

There is not enough free space for recording images. After storing the images on other media, delete unnecessary images, or format the memory card.

The image data base file may be damaged. Check the file with [ REPAIR IMAGE DB FILE ].

The memory card is damaged.

When you record movies whose bit-rate is set to 100 Mbps in [ **REC FORMAT**], use an SDXC memory card of UHS-I U3 or faster .

 (Warning indicator pertaining to memory card formatting)

The memory card is damaged.

The memory card is not formatted correctly .

 (Warning indicator pertaining to incompatible memory card)

Incompatible memory card is inserted.

 (Warning indicator pertaining to the write-protect of the memory card)

The memory card is write-protected.

Access to the memory card was restricted on another device.

 (Warning indicator pertaining to camera-shake warning)

The camcorder is unsteady , so camera-shake easily occurs. Hold the camcorder steady with both hands and record the image. However , note that the camera shake warning indicator does not disappear .

#### ND filter warning

When **ND1**, **ND2**, **ND3** or **NDOff** is flashing, check the position of the ND filter switch is correct.

---

#### Related Topic

- [If you have problems](#)
- [Inserting a memory card](#)
- [MEDIA FORMAT](#)
- [About the InfoLITHIUM battery pack](#)
- [REPAIR IMAGE DB FILE](#)
- [STEADYSHOT \(Movie\)](#)
- [STEADYSHOT \(Photo\)](#)
- [Adjusting the light quantity \(ND filter\)](#)

Digital 4K Video Camera Recorder  
FDR-AX700

## Warning Indicators

If messages appear on the LCD monitor, follow the instructions.

### Data error

- This may occur when you keep applying shock to the camcorder.
- Movies recorded on other devices may not be played back.

### Inconsistencies found in image database file. Do you want to reformat the image database file?

- You cannot record or play back movies because image management file is damaged. Select  to record or play back HD movies.

### Buffer overflow. Writing to the media was not completed in time.

- You have performed recording and erasing operations repeatedly, or a memory card that has been formatted by other device is used. Copy and take data backup to other device (such as a computer), and then format the memory card on the camcorder.
- The size of the inserted memory card is not sufficient for copying the movie(s). Use the recommended memory card.

### Recovering data. Please wait.

- If writing data onto memory card of the camcorder has failed, attempts will be automatically made to recover the data.

### Cannot recover data.

- Writing data onto the memory card has failed. Attempts were made to recover the data, but they were unsuccessful. The camcorder may not be able to write data onto the memory card or edit data.

### Reinsert the memory card.

- Reinsert the memory card a few times. If the indicator continues to flash even after reinserting, the memory card could be damaged. Try with another memory card.

### Cannot recognize this memory card. Format and use again.

- Format the memory card. Note that when you format the memory card, all the recorded movies and photos are deleted.

### The maximum number of still image folders has been reached. Cannot record still images.

- You cannot create folders exceeding 999MSDCF. You cannot create or delete created folders using the camcorder.
- Format the memory card, or delete folders using your computer.

This memory card may not be able to record or play movies.

This memory card may not be able to record or play images correctly.

- Use a memory card recommended for the camcorder.

Do not eject the memory card during writing. Data may be damaged.

- Reinsert the memory card.

### Others

Maximum number of images already selected.

- You can select only 100 images at one time for:
  - Deleting movies/photos
  - Protecting movies/photos, or releasing the protection

Protected file. Cannot delete.

- You tried to delete protected data. Release the protection of the data.

---

Related Topic

- [REPAIR IMAGE DB FILE](#)
- [MEDIA FORMAT](#)
- [Protecting movies and photos \( PROTECT\)](#)
- [Deleting selected movies/photos](#)

4-725-312-11(2) Copyright 2017 Sony Corporation