

# French Door Refrigerator

professional series

**E23BC79SPS**



## PRODUCT DIMENSIONS

Height	69-1/2"
Width	35-5/8"
Depth (Including Door)	26-7/8"

## MORE EASY-TO-USE FEATURES

### Custom-Design™ Glass Shelves

All glass shelves are as beautiful as they are functional. The flexible shelves can be arranged in a variety of configurations to fit wide and tall items.

### Wave-Touch® Controls

Sleek control panel illuminates with a touch and fades away to an uncluttered display after an option is selected.

### Smooth-Glide® Crisper Drawers

Crisper Drawers smoothly glide out and keep even the most delicate fruits and vegetables fresh with adjustable humidity control and minimal temperature variation.

### Smooth-Glide® Freezer Drawers

Drawers glide out smoothly and fully extend giving you easy access to what's inside.

### Largest Number of Preset Selections

Nine preset selections including White/Sparkling Wine, Cheese, Fish/Shellfish or even Perfect Marinade so you can perfectly marinate your beef tenderloin.

### Alarm System

Notifies you if there's been a power failure, if a door stays open longer than five minutes and if the interior temperature of the refrigerator ever rises above 56 degrees for more than 20 minutes.

### "My Favourite" Settings

Customize these 3 settings to store your favourite items at the ideal temperature.

### Twice the Ice

You get filtered, restaurant-quality ice featuring a new drink-friendly shape, twice the ice as any refrigerator ice maker — up to 9 pounds in 24 hours.

Available In:



Stainless  
(S)

## Signature Features



### Custom Temp Drawer™

Enjoy the ultimate in versatility with 9 preset selections including White/Sparkling Wine, Fish/Shellfish, Cheese plus three customizable settings that ensure foods stay at the ideal temperature for serving and maintaining freshness.



### Custom-Design™ Organization System

With our flexible Tri-Level freezer organization system you can keep your freezer well organized. The three Smooth-Glide® baskets with removable dividers and top removable baskets allow you to configure the space to neatly fit large and small items.



### Theatre Lighting

Transition LED lighting gradually illuminates the interior with soft but ample light as you open the door.



### PureAdvantage® Filtration Systems

Our filtration system keeps clean, filtered air circulated throughout to prevent odour transfer and keeps fresh, clean water and ice at your fingertips.

# French Door Refrigerator

E23BC79SPS professional series



## 22 CU.FT. COUNTER-DEPTH FRENCH DOOR REFRIGERATOR

### CAPACITIES

Total Capacity	21.5 Cu. Ft.
Fresh Food Volume	14.66 Cu. Ft.
Freezer Volume	6.81 Cu. Ft.
Total Shelf Area	19.93 Sq. Ft.
Fresh Food Shelf Area	18.75 Sq. Ft.
Freezer Shelf Area	5.67 Sq. Ft.

### EXTERIOR

Professional Door and Handle Design	Yes
Electronic Controls	Wave-Touch®
Hidden Hinge Door Design	Yes
Ice/Water Dispenser	Yes
Custom-Set™ Temperature Control System and Display	Yes
Crushed Ice/Cube Ice/Water	Yes/Yes/Yes
Air and Water Filter Indicator/Reset	Yes
Ice Maker On/Off	Yes
Fast Freeze™	Yes
Lock/Dispenser Light Control	Yes/Yes

### FRESH FOOD CONVENIENCES

3M PureAdvantage® Water & Ice	Yes
PureAdvantage® Air Filtration/Water Filter Location	Yes/Bottom Left
Temp Alarm System/Door Ajar Alarm	Yes/Yes
Power Failure Alarm	Yes
Custom-Design™ Glass Shelves	Flat, Lift-Off
Humidity-Controlled Left Crisper	Smooth-Glide®
Humidity-Controlled Right Crisper	Smooth-Glide®
Custom Temp Drawer™	Yes
Wine and Beverage Rack	Yes
Clear Gallon Door Bins (Adjustable)	1
Clear 1/2-Gallon Door Bins (Adjustable)	1
Clear Dairy Door	Yes
Clear Tilt-Out Can Racks	2
Theatre Ramp-Up Multilevel Lighting – LED	Yes
Automatic Ice Maker	Yes

### FREEZER CONVENIENCES

Self-Closing Drawer	Yes
Sliding Freezer Baskets	Yes
Soft Freeze™ Bin/Wire Pizza Slot	No/Yes
Fast Ice™/Fast Freeze™	No/Yes
Plastic Basket Tray	
Theatre Ramp-Up Multilevel Lighting – LED	Yes

### ADDITIONAL FEATURES

ENERGY STAR®	Yes
Sabbath Mode (Star-K® Certified)	Yes

### ACCESSORIES

Collar Kit – PN# ECK23CDS*	Optional
Louvered Trim Kit – PN# 241723001*	Optional
Water Filter Replacement Cartridge – PN# EWF02	Optional
Air Filter Replacement Cartridge – PN# EAFCBF	Optional

### SPECIFICATIONS

Power Supply Connection Location	Right Bottom Rear
Water Inlet Location	Left Bottom Rear
Voltage Rating	120V/60 Hz
Connected Load (kW Rating) @ 120 Volts†	1.02
Minimum Circuit Required (Amps)	15
Shipping Weight (Approx.)	347 Lbs.

\*For detailed Louvered Trim Kit and Collar Kit installation instructions, refer to Product Installation Guides on the web at [electroluxicon.ca](http://electroluxicon.ca).

†An electrical supply with grounded three-prong receptacle is required. The power supply circuit must be installed in accordance with national and local codes & ordinances.

NOTE: Always consult local and national electric codes. Refer to Product Installation Guide for detailed installation instructions on the web at [electroluxicon.ca](http://electroluxicon.ca).

Specifications subject to change.

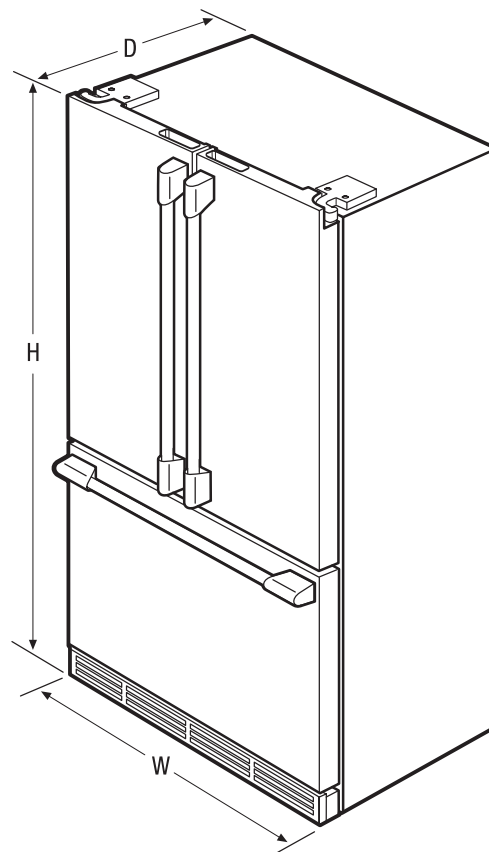

### PRODUCT DIMENSIONS

Height (Including Door)	69-1/2"
Width	35-5/8"
Depth (Including Door)	26-7/8"
(with Door 90° Open)	42-9/16"
(with Drawer Fully Extended)	46"

## Electrolux Major Appliances, N.A.

CANADA • 5855 Terry Fox Way • Mississauga, ON L5V 3E4 • 1-800-265-8352 • [electroluxicon.ca](http://electroluxicon.ca)

E23BC79SPS 04/17

© 2017 Electrolux Major Appliances, N.A.

Printed in Canada



High standards of quality at Electrolux Home Products, Inc. mean we are constantly working to improve our products. We reserve the right to change specifications or discontinue models without notice.