

INSTRUCTION MANUAL

MILK FROTHER

MANUEL D'UTILISATION

MOUSSEUR À LAIT

MANUAL DE USO

ESPUMADOR DE LECHE

EN

FR

ES



Important information for the user
Informations importantes pour l'utilisateur
Información importante para el usuario



Recommendations / Avertissements / Advertencias



Description / Description / Descripción



Use / Utilisation / Uso



**Cleaning and care / Nettoyage et entretien /
Limpieza y mantenimiento**



**Safety instructions / Consignes de sécurité /
Advertencia de seguridad**



Information / Information / Información



Advice / Conseil / Sugerencia

Dear Customer, Thank you for purchasing one of our appliances. Our products are unique because they combine iconic style with innovative technical solutions. They match perfectly with other products in our range and work equally well as standalone design objects in your kitchen. We hope you enjoy using your new appliance! Best regards.

Cher client, merci beaucoup pour votre achat. Nos produits sont uniques car ils combinent une forte recherche esthétique avec une conception technique innovante. Ils sont coordonnés avec d'autres produits de la gamme et peuvent constituer des éléments d'ameublement et de design. En espérant que vous pourrez apprécier pleinement votre nouvel appareil électroménager, nous vous adressons nos meilleures salutations.

Estimado cliente, le damos las gracias por su compra. Nuestros productos son únicos porque combinan una notable búsqueda estética con un diseño técnico innovador. Se combinan con otros productos de la gama y se pueden utilizar como elementos de decoración y diseño. Le deseamos que pueda apreciar plenamente su nuevo electrodoméstico. Le enviamos nuestros saludos más cordiales.

SMEG S.p.A.

A

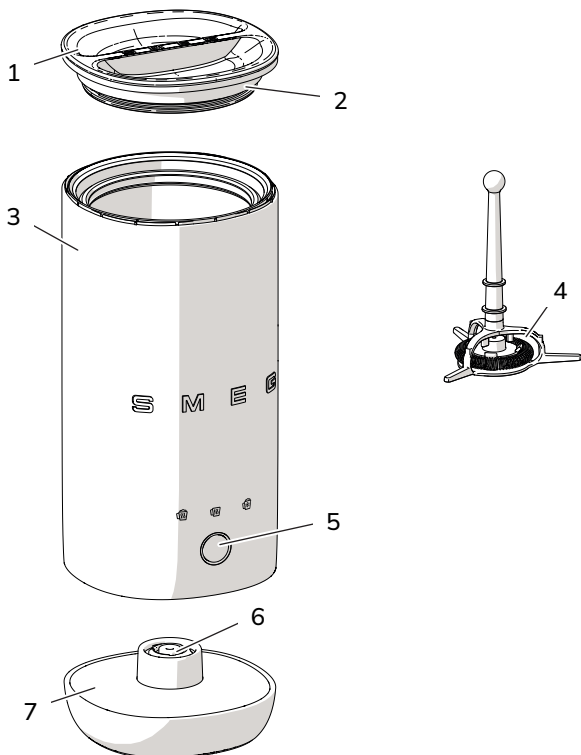

B

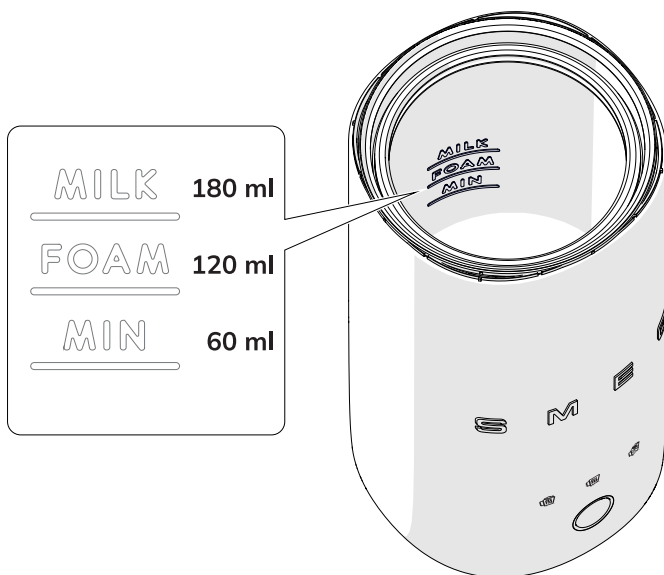

C

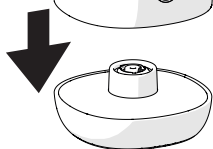
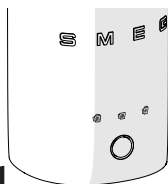
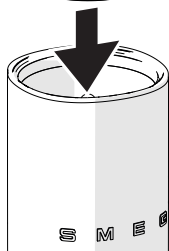
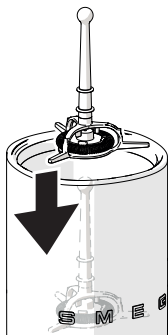
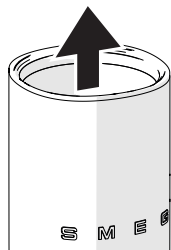

D

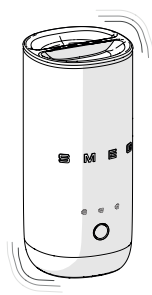
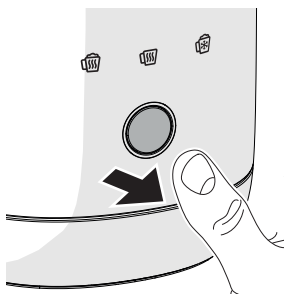
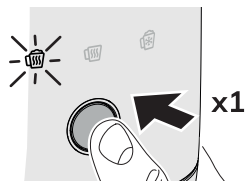



IMPORTANT SAFEGUARDS

WARNING: If the instructions contained in this manual are not followed precisely, a fire or explosion may result causing property damage, personal injury or death.

WARNING



- Basic safety precautions should always be followed when using the appliance.
- A short power cord should be provided to minimize the risk of entanglement.
- Extension cords are available if used with care.
- If an extension cord is used, the marked electrical rating of the extension cord should be at least as great as 15A. The extension cord should be a grounding 3-wire cord. The longer cord should be arranged so that it does not drape over the countertop or table top where it can be pulled on by children or tripped over unintentionally.



READ AND SAVE THESE INSTRUCTIONS

Your safety and the safety of others are very important.

We have provided many important safety messages throughout this manual and on the appliance.

Read all the instructions before using the appliance and always obey all safety messages.



RECOGNIZE SAFETY INFORMATION

This is the safety alert symbol. This symbol alerts you to potential hazards that can result in severe personal injury or death.

UNDERSTAND SIGNAL WORDS

A signal word – DANGER, WARNING, or CAUTION – is used with the safety alert symbol. DANGER denotes the most serious hazards. It means you could be killed or seriously injured if you do not immediately follow the instructions. WARNING means you could be killed or seriously injured if the instructions are not followed. CAUTION indicates a potentially hazardous situation, which, if not avoided, could result in minor to moderate injury.

WARNING



- This appliance is intended for household use only.
- Use this appliance only for its intended purpose. The manufacturer cannot be held liable for damage caused by improper use of this appliance.
- This appliance complies with current safety regulations. Improper use can result in personal injury and material damage.
- Read all the instructions before installing or using the appliance for the first time.
- Keep these operating instructions in a safe place and pass them on to any future user.
- Do not use the appliance for other than intended use.



IMPORTANT SAFEGUARDS

The safety messages will inform you of potential hazards, on how to avoid the risk of injury and what can occur if the instructions are not followed.

IMPORTANT: Observe all codes and ordinances in force.

WARNING: For your safety, the instructions contained in this manual must be followed to minimize the risk of fire or explosion and to prevent property damage, personal injury or death.

Do not store or use gasoline or other flammable vapors, liquids or materials near this or any other appliance.



NOTE: This appliance is NOT designed for installation in manufactured (mobile) homes or in recreational vehicles (RVs).

DO NOT install this appliance outdoors.

IMPORTANT SAFEGUARDS



WARNING



To reduce the risk of fire, electrical shock, personal injury, or damage when using the appliance, follow basic safety precautions, including the following:

WARNING



- Basic safety precautions should always be followed when using electrical appliances.
- Do not touch hot surfaces. Use handles or knobs.
- To protect against electric shock do not immerse the appliance, power cord or plug in water or any other liquid.
- Close supervision is necessary when any appliance is used by or near children.
- Allow to cool before putting on or taking off parts, and before cleaning the appliance.
- Do not operate any appliance with a damaged cord or plug or after the appliance malfunctions, or has been damaged in any manner. Return appliance to the nearest authorized service facility for examination, repair or adjustment.
- The use of accessory attachments not recommended by the appliance manufacturer may cause injuries.
- Do not let cord hang over edge of table or counter, or touch hot surfaces.
- Do not place on or near a hot gas or electric burner, or in a heated oven.
- Extreme caution must be used when moving an appliance containing hot oil or other hot liquids.



IMPORTANT SAFEGUARDS

1 Instructions

This manual is an integral part of the appliance and must be kept in its entirety and within easy reach throughout the life of the appliance.

1.1 Intended use

Failure to observe the safety warnings and read the instruction manual may result in improper use of the appliance and personal injury.

- Only use the appliance indoors and at a maximum altitude of 2000 meters.
- This appliance is intended for household use and similar use such as:
 - staff kitchen areas in shops, offices and other work environments
 - bed and breakfast facilities/farm stay accommodation
 - by guests in hotels, motels and other residential-type environments.
- This appliance is not designed for use with external timers or remote control systems.

- Use the appliance indoors and protected from the elements.
- This appliance is not intended for use by persons with reduced physical, sensory or mental abilities (including children under the age of 8) unless they are supervised or have been properly instructed on how to use the appliance safely.

1.2 General safety instructions

Follow all safety instructions in order to use the appliance safely:

- Read this user manual carefully before using the appliance.
- Do not touch hot surface.
- To protect against fire, electric shock and injury to persons do not immerse cord, plugs, or in water or other liquid.
- Close supervision is necessary when any appliance is used by or near children.

IMPORTANT SAFEGUARDS



- Do not use outdoors.
- Do not let cord hang over edge of table or counter, or touch hot surfaces.
- Do not use appliance for other than intended use.
- Always attach plug to appliance first, then plug cord into the wall outlet. To disconnect, turn any control to “off”, then remove plug from wall outlet.
- Scalding may occur if the lid is removed during the brewing cycles.
- This appliance is not intended for use by persons (including children) with reduced physical, sensory or mental capabilities, or lack of experience and knowledge, unless they have been given supervision or instruction concerning use of the appliance by a person responsible for their safety.
- If the SUPPLY CORD is damaged, it must be replaced by the manufacturer, its service agent or similarly qualified persons in order to avoid a hazard.
- Household use only.
- Do not place the appliance on or near lighted gas burners or electric hot plates, in an oven, or near any other heat source.
- Do not leave the appliance unattended while it is on.
- Avoid contact with moving parts during operation.
- Keep hands, hair, clothing and utensils away from moving parts during operation to prevent personal injury and/or damage to the appliance.
- Turn off the appliance immediately after use.
- Do not immerse the appliance, power cord or plug in water or any other liquid.



IMPORTANT SAFEGUARDS

- This appliance has a ground connection for functional purposes only.
- Never attempt to extinguish fire/flames with water: turn off the appliance, unplug the plug and smother the flames with a fire blanket or other suitable cover.
- Always disconnect the power supply before installing or removing components.
- Unplug from outlet when not in use and before cleaning. Allow to cool before putting on or taking off parts, and before cleaning the appliance.
- Use only genuine replacement parts. The use of replacement parts not approved by the manufacturer may result in fire, electric shock or personal injury.
- Do not attempt to modify or repair the appliance: in the event of a malfunction, it must be repaired by a qualified technician or by calling for technical assistance.
- Do not allow the power cord to come into contact with sharp edges.
- Do not pull on the cord to remove the plug from the wall outlet.
- Return appliance to the nearest authorized service facility for examination, repair or adjustment.
- Do not use the appliance if the power cord or plug is damaged, or if the appliance has been dropped or damaged in any way.
- If the power cord is damaged, contact technical support immediately for replacement.
- Children must never play with the appliance. Keep the appliance and power cord out of the reach of children.
- Use the appliance only with the power base provided.
- To prevent damage, do not spill liquids into the socket.



- The surface of the heating element may remain hot after use.
- Do not allow children to clean or service the appliance without supervision.
- A short power-supply cord is provided to reduce risks resulting from becoming entangled in or tripping over a longer cord.
- Longer detachable power-supply cords or extension cords are available and may be used if care is exercised in their use.
- If a long detachable power-supply cord or extension cord is used:
- The marked electrical rating of the detachable power-supply cord or extension cord should be at least as great as the electrical rating of the appliance.
- If the appliance is of the grounded type, the extension cord should be a grounding-type 3-wire cord.
- The longer cord should be arranged so that it will not drape over the counter top or table top where it can be pulled on by children or tripped over.

1.3 Caution

- Do not use the milk frother without the lid.
- Check that the lid is properly closed before switching on the milk frother.
- Do not overfill the milk frother.
- Do not use the milk frother with parts or accessories from other manufacturers.
- Place the milk frother only on flat, dry surfaces.
- Do not use the milk frother when it is empty to avoid permanent damage to the whisk.
- Do not use the milk frother as a storage container. Keep the frother empty before and after use.
- Do not place metal objects such as knives, forks and spoons on the appliance during use.
- For instructions on how to clean the appliance properly, please refer to section “4 Cleaning and maintenance”.



IMPORTANT SAFEGUARDS

1.4 Connecting the appliance

Make sure that the power supply voltage and frequency match those specified on the data plate on the bottom of the appliance.

In case of incompatibility between the power outlet and the plug of the appliance, contact the technical support service for replacement.

1.5 Manufacturer's liability

The manufacturer declines all liability for damage to persons or property caused by:

- Use of the appliance other than for its intended purpose.
- Not having read the user manual.
- Tampering with any part of the appliance.
- The use of non-genuine spare parts.
- Failure to follow the safety instructions.



Please keep this instruction manual in a safe place. If the appliance is passed on to another person, please give them this manual as well.

This manual can be downloaded from the Smeg website "www.smeg.com".

1.6 Disposal



Appliances marked with this symbol are subject to the requirements of European Directive 2012/19/EU.

- All waste electrical and electronic appliances must be disposed of separately from household waste and taken to an authorized waste disposal facility. Correct disposal of this appliance will help protect the environment and human health. For more information on how to dispose of this appliance, please contact your local waste disposal office or the shop where you purchased the appliance.

SAVE THESE INSTRUCTIONS



2 Appliance description (Fig. A)

- 1) Lid
- 2) Seal
- 3) Milk frother
- 4) Whisk
- 5) Function selector and start button
- 6) Connector
- 7) Base



The accessories that come into contact with food are made of materials that comply with current legislation.

2.1 Identification plate

The identification plate shows the technical data, the serial number and the brand name of the appliance.

Do not remove the identification plate for any reason.



Description

2.2 Level indicators (Fig. B)

The level indicators are located inside the container and in the notches on the whisk.

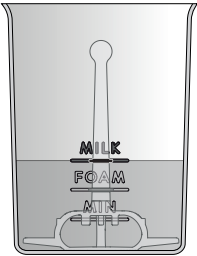
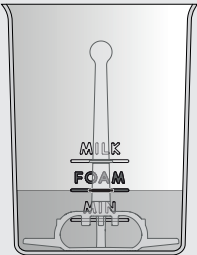
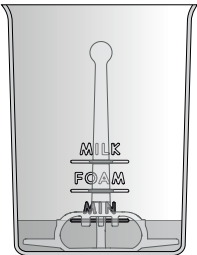
Symbol	Description
	Maximum milk level for “hot milk function”.
	Maximum milk level for “hot/cold frothing function”.
	Minimum milk level.



3 Use

3.1 Before first use



Danger of electrocution

Plug the appliance into a suitable grounded outlet.

- Do not remove the grounding prong.
- Do not use an adapter.
- Do not use an extension cord.
- Failure to follow these instructions could result in death, fire, or electric shock.

Perform a pre-cleaning cycle before using the appliance:

- 1) Remove the lid (1) from the milk frother (3).
- 2) Insert the whisk (4) into the milk frother (3).
- 3) Fill the milk frother (3) with fresh, still drinking water up to the level mark (FOAM=120ml).
- 4) Place the lid (1) on the milk frother (3).
- 5) Place the milk frother (3) correctly on its base (7).
- 6) Press the button (5) and wait 3 seconds for the cleaning cycle to start.
- 7) The appliance will beep three times to indicate the end of the cleaning cycle.
- 8) Remove the milk frother (3) from the base (7) and empty it.
- 9) Wash and dry thoroughly (see "4.1 Cleaning components").



Risk of unintended start

Make sure the milk frother is unplugged before attaching or removing the whisk.



Use

3.2 Heating or frothing the milk (Fig. C and D)



Do not use the appliance without liquid. Starting the appliance without liquid can damage the jug.

Always fill to the MIN level and never higher than the MILK level, both of which are indicated inside the milk frother.



For an ideal hot milk froth, use cold (4-8°C) whole milk (pasteurized or UHT) from the refrigerator. Avoid using room temperature milk.

- 1) Remove the lid (1) from the milk frother (3).
- 2) Insert the whisk (4) into the milk frother (3).



Do not use the frother without the whisk.

- 3) Pour cold milk into the milk frother (3). Observe the level indicators inside the milk frother.
- 4) Place the lid (1) on the milk frother (3).
- 5) Place the milk frother (3) correctly on its base (7).



The appliance is now on and ready for use.

- 6) Press the button (5) to select one of the three available functions:



- Hot foam function (8)

Press the button (5) once; the “hot foam function” LED will light up.

- Hot milk function (9)

Press the button (5) twice; the “hot milk function” LED will light up.

- Cold foam function (10)

Press the button (5) three times; the “cold foam function” LED will light up.



Press the button (5) again to turn off all LEDs.

- 7) To activate the desired function, select the mode and wait 3 seconds. The function will start automatically.



You can stop the cycle before the set time by pressing the button (5).

- 8) The end of the cycle is indicated by three beeps and the LED of the selected function goes out.
- 9) Remove the milk frother (3) from the base (7).
- 10) Remove the lid (1) and pour the hot or frothed milk into the cup.



After use, the appliance automatically switches to standby mode after 1 minute of inactivity.

Standby power consumption: 0.1 W (according to the ERP directive).



Cleaning and maintenance

4 Cleaning and maintenance



Improper use. Danger of electrocution

- Unplug the milk frother before cleaning.
- Do not immerse the base in water or other liquids.



Improper use. Risk of damage to surfaces.

- Do not use steam jets to clean the appliance.
- Do not use detergents containing chlorine, ammonia or bleach on parts with metallic surfaces (e.g. anodized, nickel-plated or chrome-plated).
- Do not use abrasive or corrosive detergents (e.g. powder products, stain removers and metallic scourers).
- Do not use rough or abrasive materials or sharp metal scrapers.

4.1 Cleaning components

To facilitate cleaning, it is recommended that the components be cleaned regularly after each use after they have cooled down.



Lid	✓	✓
Milk frother	✓	x
Whisk	✓	✓
Base	✓	x



Make sure the components are completely dry before placing them back into the milk frother.

What to do if...

Problem	Possible cause	Solution
	The appliance is not plugged in.	Make sure the power cord is properly plugged into the power outlet.
	The appliance is plugged into multiple outlets or a power strip.	Plug the appliance directly into an outlet.
Milk frother does not start	No power.	Make sure the main circuit breaker is turned on.
	Milk frother is not inserted correctly.	Ensure that the milk frother is correctly placed on the base and that there are no foreign objects between the base and the milk frother that could prevent it from working properly.
Milk frother does not froth milk	There is no whisk in the milk frother or the whisk is not correctly assembled/installed.	Check that the whisk is present, assembled and correctly seated in the milk frother.

What to do if...

Problem	Possible cause	Solution
Poor quality froth	Dirty milk frother or whisk.	Make sure the milk frother and whisk are clean.
	Incorrect amount of milk.	Check that the correct amount of milk has been inserted and that it is at the correct level.
	Unsuitable milk.	It is recommended to use cold milk from the refrigerator (4-8°C) to obtain an optimal hot froth.
	Too long a period between the end of the preparation and consumption.	Pour the preparation into the cup as soon as it is ready and consume it immediately.
Milk leaks from the frother during use	There may be too much milk.	Check the level indicator.
Milk is too hot or burnt	Incorrect amount of milk.	Make sure you have not used less than the minimum amount of milk (60 ml).

What to do if...

Problem	Possible cause	Solution
Milk frother is noisy	Components are not installed correctly.	<p>Make sure the whisk is properly inserted.</p> <p>Make sure the lid is properly installed.</p>
	Foreign objects present.	<p>Make sure the appliance is on a stable surface.</p> <p>Check that there are no foreign objects inside the frother and between the base and the frother that could prevent it from working properly.</p>
Milk frother stops during operation	The frother is too hot.	Rinse the milk frother with cold water and refill with cold milk.
	Milk is too hot.	Do not use preheated milk. Use cold milk.



If the problem persists or for any other malfunction, contact your local service center.

The manufacturer reserves the right to make any changes deemed necessary for the improvement of its products without prior notice. The illustrations and descriptions contained in this manual are therefore not binding and are merely indicative.

Le fabricant se réserve la faculté d'apporter, sans préavis, toutes les modifications qu'il jugera utiles pour l'amélioration de ses produits. Les illustrations et les descriptions figurant dans ce manuel ne sont pas contraignantes et n'ont qu'une valeur indicative.

El fabricante se reserva el derecho a aportar sin aviso previo todas las modificaciones que considere útiles para la mejora de sus propios productos. Las ilustraciones y las descripciones contenidas en este manual no son vinculantes y tienen solo valor indicativo.

