



60938 - DELUXE GRILL LIGHT AND TIMER 60938 - LUMIÈRE FOUR ET MINUTEUR - PREMIUM



Broil King®
Great Barbecues Every Time

INSTRUCTIONS

LIGHT FUNCTION:

- Press POWER  key to turn on lights.
- Rotate lights to desired position.
- Press POWER  key to turn off lights.

TIMER SCREEN FUNCTION:

- Press (Play / Stop ) key to turn on timer function.
- Press any button (TIME, TURNS, Play / Stop ) to turn on back light for 10 sec.
- Press TIME button to adjust time.
- Hold TIME button to fast scroll through times.
- Time value setting range 00:00 - 90:00 mins

00:00-05:00 Range

Press "TIME" button to add 30s.

05:00-20:00 Range

Press "TIME" button to add 1 min.

20:00-60:00 Range

Press "TIME" button to add 5 min.

60:00-90:00 Range

Press "TIME" button to add 10 min.

To reset the timer, hold (Play / Stop) for 3 sec. Time will reset to 00:00.

During stopped time, the screen will enter sleep mode after 30 seconds to conserve power.

Press any button (TIME, TURNS, Play / Stop ) to resume.

TURN ALERT:

This unique feature will remind you when it is time to turn your food.

- To set a turn alert, use the TURNS button.
- The default setting for the number of turns is 1.
- The number of turns can be set between 1 and 4 turns.

EXAMPLE 1:

8 Min Perfect 1" NY Strip Steak

- Set Timer to 8:00 min
- Set Turns for 4
- Place the steak on the pre-heated grill and press (Play / Stop ) to start the timer.
- The timer will activate an audio/visual alert every 2 min, reminding the griller to flip the steak. Alerts will occur at 6:00 min, 4:00 min, 2:00 min and 0:00 min.

EXAMPLE 2:

- Set Timer to 20:00 min
- Set Turns for 2
- The timer will activate an audio/visual alert every 10 min, reminding the griller to turn meat. Alerts will occur at 10:00 min, 0:00 min.

Digital Readout

Affichage numérique

Pantalla digital

Digitalanzeige

Time Button

Touche de minuterie

Botón de tiempo

Zeit Taste

Play/Stop Button

Touche démarrer/arrêter

Botón de arrancar/parar

Start/Stop Taste

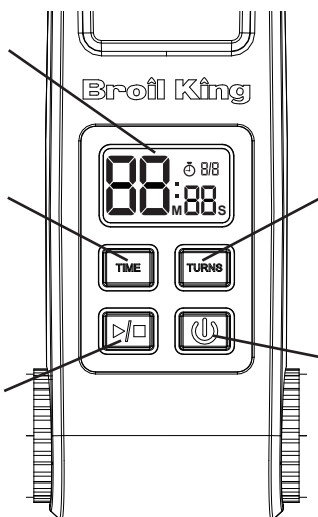

Turns Button

Touche de rotation

Botón de dar vuelta

Dreh/Wende Hinweis Taste

Power Button

Touche marche/arrêt (Power)

Botón de encendido

Power Taste

Adjustable Handle Clamp

Poignée à pince réglable

Abrazadera ajustable para manija

Verstellbare Griffklemme

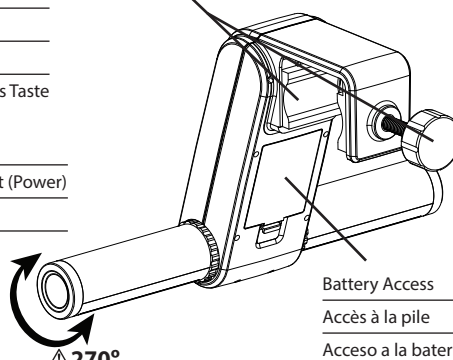

Battery Access

Accès à la pile

Acceso a la batería

Batteriezugriff

Time Remaining

Durée restante

Tiempo restante

Verbleibende Zeit

Turns Remaining

Nombre de rotations restantes

Vueltas restantes

Verbleibende Drehungen/Wendungen

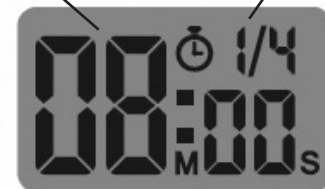

MADE IN CHINA FOR: | FABRIQUÉ EN CHINE POUR: | HERGESTELLT IN CHINA FÜR:

ONWARD MANUFACTURING COMPANY LIMITED

585 Kumpf Drive • Waterloo, Ontario, Canada • N2V 1K3 ©2021

Broil King® Deutschland GmbH



Spinnerweg 51-54 • 53783 Eitorf ©2021

www.broilingbbq.com



1-800-474-5776

INSTRUCTIONS

FONCTION DE LAMPE :

- Appuyez sur la touche POWER  pour allumer la lampe.
- Tournez les lumières à la position désirée.
- Appuyez sur la touche POWER  pour éteindre la lampe.

FONCTION D'ÉCRAN DE MINUTERIE :

- Appuyez sur la touche (Play / Stop ) pour activer la fonction de minuterie.
- Appuyez sur n'importe quelle touche (TIME, TURNS, Play / Stop ) pour allumer le rétroéclairage pendant 10 sec.
- Appuyez sur la touche TIME pour régler l'heure.
- Maintenez enfoncée la touche TIME pour défiler rapidement les durées.
- Plage de durées 00:00 - 90:00 min

Plage 00:00-05:00

Appuyez sur la touche TIME pour ajouter 30 secondes.

Plage 05:00-20:00

Appuyez sur la touche TIME pour ajouter 1 minute.

Plage 20:00-60:00

Appuyez sur la touche TIME pour ajouter 5 minutes.

Plage 60:00-90:00

Appuyez sur la touche TIME pour ajouter 10 minutes.

Pour réinitialiser la minuterie, maintenez enfoncée la touche (Play / Stop ) pendant 3 secondes. La minuterie se réinitialisera à 00:00.

Quand la minuterie est arrêtée, l'écran passera en mode sommeil après 30 secondes pour économiser de l'énergie. Appuyez sur n'importe quelle touche (TIME, TURNS, Play / Stop ) pour reprendre.

ALERTE DE ROTATION :

Cette fonctionnalité unique vous rappellera quand il est temps de tourner votre nourriture.

- Pour régler une alerte de rotation, appuyez sur la touche TURNS.
- Le paramètre par défaut pour le nombre de rotations est 1.
- Le nombre de tours peut être réglé entre 1 et 4 rotations.

EXEMPLE 1 :

Le contrefilet NY de 2,5 cm parfait en 8 minutes

- Réglez la minuterie à 08:00 min
- Réglez le nombre de rotations à 4
- Placez le bifteck sur le gril préchauffé et appuyez sur la touche (Play / Stop ) pour démarrer la minuterie.
- La minuterie activera une alerte audio/visuelle toutes les 2 minutes, vous rappelant qu'il est temps de tourner le bifteck. Vous entendrez des alertes à 06:00 min, 04:00 min, 02:00 min et 0:00 min.

EXEMPLE 2 :

- Réglez la minuterie à 20:00 minutes
- Réglez le nombre de tours à 2
- La minuterie activera une alerte audio/visuelle toutes les 10 minutes, vous rappelant qu'il est temps de tourner le bifteck. Vous entendrez des alertes à 10:00 min et 0:00 min.



60938 - LUZ PARA BARBACOA DELUXE Y TEMPORIZADOR

60938 - LED GRILLICHT DELUXE



Broil King®
Great Barbecues Every Time

INSTRUCCIONES

FUNCIÓN DE LUZ:

- Presione el botón de encendido  para encender la luz.
- Rote la luz hasta la posición deseada.
- Presione el botón de encendido  para apagar la luz.

FUNCIÓN DE TEMPORIZADOR:

- Presione el botón de arrancar/parar  para activar la función de temporizador.
- Presione cualquier botón (TIME, TURNS, arrancar/parar ) para encender la iluminación de la pantalla durante 10 segundos.
- Presione el botón TIME para ajustar el tiempo.
- Mantenga presionado el botón TIME para avanzar rápido.
- El rango de ajuste de tiempo es de 00:00 a 90:00 minutos.

Rango 00:00-05:00

Presione el botón "TIME" para agregar 30 segundos.

Rango 05:00-20:00

Presione el botón "TIME" para agregar 1 minuto.

Rango 20:00-60:00

Presione el botón "TIME" para agregar 5 minutos.

Rango 60:00-90:00

Presione el botón "TIME" para agregar 10 minutos.

Para reiniciar el temporizador, mantenga presionado (arrancar/parar ) durante 3 segundos. El tiempo volverá a 00:00.

Cuando el tiempo esté detenido, la pantalla entrará en el modo de reposo luego de 30 segundos para ahorrar energía.

Presione cualquier botón (TIME, TURNS, arrancar/parar ) para continuar.

ALERTA DE DAR VUELTA:

Esta función exclusiva le recordará cuando tenga que dar vuelta la comida.

- Para programar una alerta de dar vuelta, use el botón TURNS.
- El ajuste inicial para la cantidad de vueltas es 1.
- La cantidad de vueltas se puede ajustar de 1 a 4.

EJEMPLO 1:

Filete perfecto de 1" en 8 minutos

- Ajuste el temporizador a 8:00 minutos
- Ajuste las vueltas a 4
- Coloque el filete sobre la parrilla precalentada y presione (arrancar/parar ) para encender el temporizador.
- El temporizador activará una alerta audio/visual cada 2 minutos, recordándole al parrillero que tiene que dar vuelta el filete. Las alertas ocurrirán a los 6:00, 4:00, 2:00 y 0:00 minutos

EJEMPLO 2:

- Ajuste el temporizador a 20:00 minutos
- Ajuste las vueltas a 2
- El temporizador activará una alerta audio/visual cada 10 minutos, recordándole al parrillero que tiene que dar vuelta la carne. Las alertas ocurrirán a los 10:00 y a los 0:00 minutos.

Digital Readout
Affichage numérique
Pantalla digital
Digitalanzeige

Time Button
Touche de minuterie
Botón de tiempo
Zeit Taste

Play/Stop Button
Touche démarrer/arrêter
Botón de arrancar/parar
Start/Stop Taste

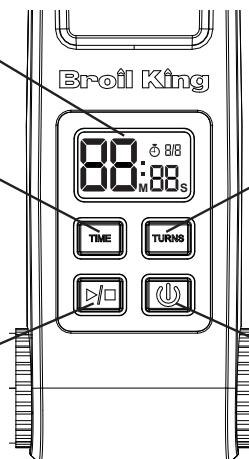



Turns Button
Touche de rotation
Botón de dar vuelta
Dreh/Wende Hinweis Taste



Power Button
Touche marche/arrêt (Power)
Botón de encendido
Power Taste

Anleitung

LICHTFUNKTION:

- Drücken Sie die (POWER ) Taste, um die Beleuchtung einzuschalten.
- Die Lichter in die gewünschte Position drehen.
- Drücken Sie die (POWER ) Taste, um die Beleuchtung auszuschalten.

TIMER-BILDSCHIRM-FUNKTION:

- Drücken Sie die (Start/Stopp ) Taste, um die Timer-Funktion einzuschalten.
- Drücken Sie eine beliebige Taste (TIME, TURNS, Start/Stopp ) , um die Hintergrundbeleuchtung für 10 Sekunden einzuschalten.
- Drücken Sie die (TIME) Taste, um die Zeit einzustellen.
- Halten Sie die (TIME) Taste gedrückt, um schnell durch die Zeit zu scrollen.
- Der Zeitwert kann von 00:00 – 90:00 Minuten eingestellt werden.

00:00 – 05:00 Bereich

Drücken Sie die TIME-Taste, um 30 Sek. hinzuzufügen.

05:00 – 20:00 Bereich

Drücken Sie die TIME-Taste, um 1 Min. hinzuzufügen.

20:00-60:00 Bereich

Drücken Sie die TIME-Taste, um 5 Min. hinzuzufügen.

60:00-90:00 Bereich

Drücken Sie die TIME-Taste, um 10 Min. hinzuzufügen.

Um den Timer zurückzusetzen, halten Sie (Start/Stopp ) 3 Sek. lang gedrückt. Die Zeit wird auf 00:00 zurückgesetzt.

Während der gestoppten Zeit wechselt der Bildschirm nach 30 Sek. in den Energiesparmodus, um Strom zu sparen.

Drücken Sie eine beliebige Taste (TIME, TURNS, Start/Stopp ) , um fortzufahren.

DREH/WENDE HINWEIS:

Diese einzigartige Funktion erinnert Sie daran, wann es an der Zeit ist, Ihr Essen zu drehen/wenden.

- Drücken Sie die (TURNS) Taste, um einen Dreh/Wende-Hinweis festzulegen.
- Die Standarteinstellung für die Anzahl an Drehungen/Wendungen ist 1.
- Die Anzahl der Drehungen/Wendungen kann zwischen 1 und 4 Drehungen/Wendungen eingestellt werden.

BEISPIEL 1:

Perfektes 8 Minuten NY Strip Steak

- Timer auf 8 Minuten setzen
- Dreh/Wende Hinweis auf 4 setzen
- Legen Sie das Steak auf den vorgewärmten Grill und drücken Sie (Start/Stopp ) , um den Timer zu starten
- Der Timer aktiviert alle 2 Minuten einen akustischen/visuellen Hinweis und erinnert den Griller daran, das Steak zu drehen. Die Hinweise erfolgen bei 6:00 Min., 4:00 Min., 2:00 Min. und 0:00 Min.

BEISPIEL 2:

- Timer auf 20 Minuten setzen
- Dreh/Wende Hinweis auf 2 setzen
- Der Timer aktiviert alle 10 Minuten einen akustischen/visuellen Hinweis und erinnert den Griller daran, das Steak zu drehen. Die Hinweise erfolgen bei 10:00 Min. und 0:00 Min.

Adjustable Handle Clamp
Poignée à pince réglable
Abrazadera ajustable para manija
Verstellbare Griffklemme

Time Remaining
Durée restante
Tiempo restante
Verbleibende Zeit

Turns Remaining
Nombre de rotations restantes
Vueltas restantes
Verbleibende Drehungen/Wendungen

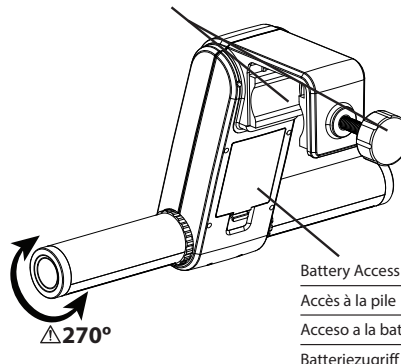

Battery Access
Accès à la pile
Acceso a la batería
Batteriezugriff

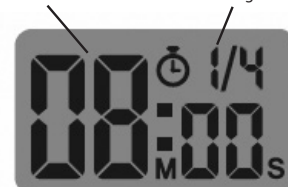

MADE IN CHINA FOR: | FABRIQUÉ EN CHINE POUR: | HECHO EN CHINA PARA: | HERGESTELLT IN CHINA FÜR:

ONWARD MANUFACTURING COMPANY LIMITED
585 Kumpf Drive • Waterloo, Ontario, Canada • N2V 1K3 ©2021

Broil King® Deutschland GmbH
Spinnerweg 51-54 • 53783 Eitorf ©2021



www.broilkingbbq.com
1-800-474-5776

60938 - LAMPADA ORIENTABILE CON TIMER 60938 - DELUXE GRILL LIGHT AND TIMER





Broil King®
Great Barbecues Every Time

ISTRUZIONI

FUNZIONAMENTO:

- Premere il tasto POWER  per accendere le luci.
- Ruotare le luci nella posizione desiderata.
- Premere il tasto POWER  per spegnere le luci.

FUNZIONE SCHERMATA TIMER:

- Premere il tasto (Play / Stop  / ) per attivare la funzione timer.
- Premere un pulsante qualsiasi (TIME, TURNS, Play / Stop  / ) per accendere la retroilluminazione per 10 secondi.
- Premere il pulsante TIME per regolare l'ora.
- Tenere premuto il pulsante TIME per scorrere velocemente i tempi.
- Intervallo di impostazione del valore temporale 00:00 - 90:00 min

00:00-05:00 Range

Premere il pulsante "TIME" per aggiungere 30s.

05:00-20:00 Range

Premere il pulsante "TIME" per aggiungere 1 min.



20:00-60:00 Range

Premere il pulsante "TIME" per aggiungere 5 min.

60:00-90:00 Range

Premere il pulsante "TIME" per aggiungere 10 min.

Per ripristinare il timer, tenere premuto (Play / Stop) per 3 secondi. L'ora verrà ripristinata a 00:00.

Durante il tempo di arresto, lo schermo entrerà in modalità di sospensione dopo 30 secondi per risparmiare energia. Premere qualsiasi pulsante (TIME, TURNS, Play / Stop  / ) per riprendere.



AVVISO PER GIRARE IL CIBO:

Questa speciale funzione ti ricorderà quando è il momento di girare il cibo.

- Per impostare un avviso per girare, utilizzare il pulsante TURNS.
- L'impostazione predefinita per il numero di giri è 1.
- Il numero di giri può essere impostato tra 1 e 4 giri.

ESEMPIO 1:

8 Min Perfect 1 "NY Strip Steak (controfiletto)

- Impostare il timer su 8:00 min
 - Impostare i giri per 4
 - Posizionare la bistecca sulla griglia preriscaldata e premere (Play / Stop  / ) per avviare il timer.
 - Il timer attiverà un avviso acustico / visivo ogni 2 minuti, ricordando di girare la bistecca.
- Gli avvisi verranno emessi ai 6:00 min, 4:00 min, 2:00 min e 0:00 min.

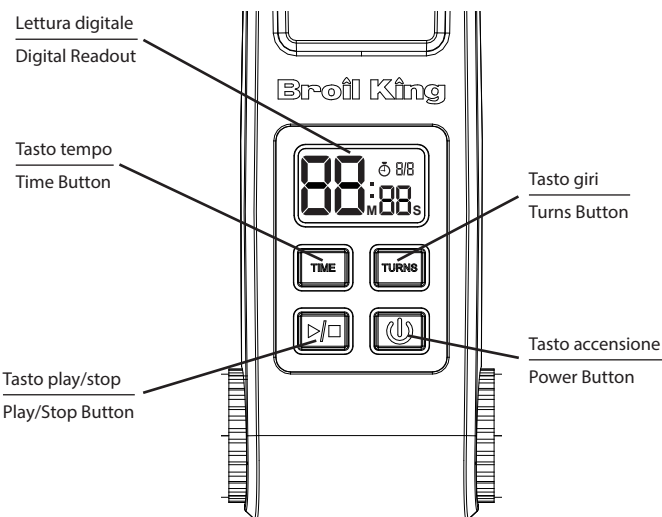

ESEMPIO 2:

- Impostare il timer su 20:00 min
 - Impostare i giri per 2
 - Il timer attiverà un avviso acustico / visivo ogni 10 minuti, ricordando di girare la carne.
- Gli avvisi si attiveranno ai 10:00 min, 0:00 min.







INSTRUCTIONS

LIGHT FUNCTION:

- Press POWER  key to turn on lights.
- Rotate lights to desired position.
- Press POWER  key to turn off lights.

TIMER SCREEN FUNCTION:

- Press (Play / Stop  / ) key to turn on timer function.
- Press any button (TIME, TURNS, Play / Stop  / ) to turn on back light for 10 sec.
- Press TIME button to adjust time.
- Hold TIME button to fast scroll through times.
- Time value setting range 00:00 - 90:00 mins

00:00-05:00 Range

Press "TIME" button to add 30s.

05:00-20:00 Range

Press "TIME" button to add 1 min.

20:00-60:00 Range

Press "TIME" button to add 5 min.

60:00-90:00 Range

Press "TIME" button to add 10 min.

To reset the timer, hold (Play / Stop) for 3 sec. Time will reset to 00:00.

During stopped time, the screen will enter sleep mode after 30 seconds to conserve power. Press any button (TIME, TURNS, Play / Stop  / ) to resume.



TURN ALERT:

This unique feature will remind you when it is time to turn your food.

- To set a turn alert, use the TURNS button.
- The default setting for the number of turns is 1.
- The number of turns can be set between 1 and 4 turns.

EXAMPLE 1:

8 Min Perfect 1" NY Strip Steak

- Set Timer to 8:00 min
- Set Turns for 4
- Place the steak on the pre-heated grill and press (Play / Stop  / ) to start the timer.
- The timer will activate an audio/visual alert every 2 min, reminding the griller to flip the steak. Alerts will occur at 6:00 min, 4:00 min, 2:00 min and 0:00 min.

EXAMPLE 2:

- Set Timer to 20:00 min
- Set Turns for 2
- The timer will activate an audio/visual alert every 10 min, reminding the griller to turn meat. Alerts will occur at 10:00 min, 0:00 min.

