

48-Inch Dual-Fuel Steam Range

CONTEMPORARY

dacor



DOP48C86DLS/DA – Silver Stainless, Natural Gas, Liquid Propane

DOP48C86DLM/DA – Graphite, Natural Gas, Liquid Propane

Features & Benefits

- Real Steam™ oven
- Dual Four-Part Pure Convection system
- SimmerSear™ brass burners
- BrightVue™ LED & halogen lighting
- Motorized 7-inch LCD control panel with SmartThings Wi-Fi connectivity
- Ultra-wide 15-inch grates
- Chef Mode guided cooking
- Auto Connect to compatible ventilation through Bluetooth
- External steam generator
- Digital temperature probe
- Self-clean oven
- SoftShut™ hinges

Weights & Dimensions

NET WEIGHT (LBS.)	564
SHIPPING WEIGHT (LBS.)	650
PRODUCT DIMENSIONS (W X H X D IN INCHES)	47 7/8 x 36 1/8 x 27 1/2

Technical Details

ELECTRICAL REQUIREMENT	240V, 60 Hz, 50A
AVAILABLE FUEL TYPES	Natural Gas, Liquid Propane
LP CONVERSION KIT (INCLUDED)	Yes

Controls

CONTROL TYPE	7" Motorized LCD Touchscreen & Knobs
CHEF MODE GUIDED COOKING	Yes
ILLUMINA™ KNOBS	White
WI-FI + SMARTTHINGS	Yes
BLUETOOTH AUTO CONNECT VENTILATION	Yes
CONTROL SHOWER LIGHTING	Yes
CLOCK	Yes
DELAY START	Yes
KITCHEN TIMER	Yes
CHILD LOCK	Yes
SABBATH MODE	Yes

Oven

OVEN CAPACITY (CU. FT.)	4.8 (Large Oven) / 1.8 (Small Oven)
CONVECTION	Dual Four-Part Pure
STEAM	Real Steam™
BAKE ELEMENT	3,000W - 8 Pass (Large Oven), 1,000W (Small Oven)
BROIL ELEMENT	4,400W - 10 Pass (Large Oven), 2,400W (Small Oven)
CONVECTION ELEMENT	2 x 1,300W (Large Oven), 2,000W (Small Oven)
INSTANTHEAT (NO PREHEAT)	Yes
TEMPERATURE PROBE	Yes
LIGHTING	BrightVue™ - LED & Halogen
SELF-CLEAN	Self-Clean, GreenClean™
SOFTSHUT™	Yes

Cooktop

NUMBER OF BURNERS	6
PERMA-FLAME™ (AUTO RE-IGNITION)	Yes
LEFT FRONT (BTU)	22,000
LEFT REAR (BTU)	16,000
CENTER FRONT (BTU)	16,000
CENTER REAR (BTU)	16,000
RIGHT FRONT (BTU)	22,000
RIGHT REAR (BTU)	9,000
BRASS BURNER CAPS	Yes
GRIDDLE	Sold Separately
WOK RING	Yes

Warranty

FULL COVERAGE	2 Years
---------------	---------

Accessories (Optional)

ARG48	Griddle for 48" Pro-Range & Rangetop
-------	--------------------------------------

48-Inch Dual-Fuel Steam Range



CONTEMPORARY

Product Dimensions

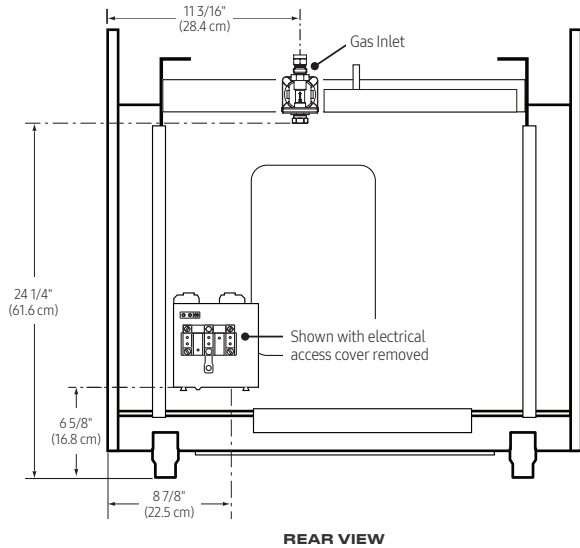
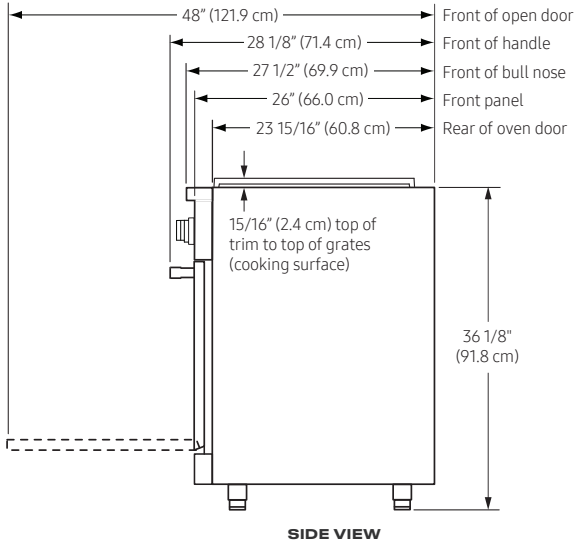

Cutout Dimensions

A - INCH / CM	Min 52 / 137.2, Max 48 / 121.9
B - INCH / CM	Min 48 / 121.9, Max 48 1/8 / 122.2
C - INCH / CM	43 1/2 / 110.5

